

Information technology Applications

APLIKÁCIE informačných technológií

1 2016

Information technology Applications / APLIKÁCIE informačných technológií 1-2016



ISSN: 2453-7497 (online)
ISSN: 1338-6488 (print version)
ISSN 1338-6466
9 771338 1646000
51





Občianske združenie VZDELÁVANIE-VEDA-VÝSKUM
Civil Association EDUCATION-SCIENCE-RESEARCH

Некоммерческая организация ОБРАЗОВАНИЕ-НАУКА-ИССЛЕДОВАНИЕ
Andrusovova 5, 851 01 Bratislava, Slovakia
www.e-s-r.org

Príspevky v časopise sú recenzované, neprechádzajú jazykovou redakciou.
Contributions in the journal have been reviewed but not edited.

Názov časopisu (Journal Title)

Aplikácie informačných technológií
Information Technology Applications

Šéfredaktor (Editor in chief)

prof. RNDr. Frank Schindler, PhD. Faculty of Informatics, Paneuropean University in Bratislava

Výkonný redaktor (Executive editor)

Ing. Michal Grell, PhD. Civil Association EDUCATION-SCIENCE-RESEARCH in Bratislava
prof. Oleg Choporov, D. Sc. Voronezh Institute of High Technologies

Redakčná rada (Editorial Board)

prof. Mikhail A. Basarab, DSc., Bauman Moscow State Technical University, Moscow, Russian Federation
prof. Ing. Ivan Brezina, CSc., Faculty of Economic Informatics, The University of Economics in Bratislava
Dr. Silvester Czanner, PhD., Mathematics and Digital Technology, Manchester Metropolitan University, United Kingdom
Dr. prof. Buchaev Yakhua Gamidovich, Dagestan State Institute of National Economy (DGINH), Russian Federation
doc. RNDr. Andrej Ferko, PhD., Faculty of Mathematics Physics and Informatics, Comenius University in Bratislava
doc. Ing. Juraj Štefanovič, PhD. MBA, Faculty of Economics, The Technical University of Košice
doc. Ing. Ladislav Hudec, CSc., Faculty of Informatics and Information Technologies, Slovak University of Technology in Bratislava
prof. RNDr. Jozef Kelemen, DrSc., Faculty of Philosophy and Science, Silasian University in Opava
Dr. Ing. Jaroslav Kultán, PhD., Faculty of Economic Informatics, The University of Economics in Bratislava
prof. V.I. Kolesnikov, Russian Academy of Science, Russian Federation
Ing. Eva Mihaliková, PhD., Faculty of Public Administration, Pavol Jozef Šafárik University in Košice
doc. RNDr. Eugen Ružický, PhD., Faculty of Informatics, Paneuropean University in Bratislava
doc. Ing. Anna Čepelová, PhD., Faculty of Public Administration, Pavol Jozef Šafárik University in Košice
prof. Ing. Jiří Voříšek, CSc., Faculty of Informatics and Statistics, University of Economics in Prague
prof. Vladimir Zuev, Institute for Social and Human Knowledge, Kazan, Russian Federation
prof. Genadij Chirko, Institute for Social and Human Knowledge, Kazan, Russian Federation



**VORONEZH INSTITUTE
OF HIGH TECHNOLOGIES**

Information Technology Applications / International Scientific Journal – 1/2016

Print: 

Publishing and Printing Centre “Nauchnaya Kniga”
32e, ul. Srednemoskovskaya, Voronezh, Russia, 394030
www.n-kniga.ru
E-mail: zakaz@n-kniga.ru

Časopis vychádza dvakrát do roka.

The journal is published twice times a year.

Časopis je recenzovaný, číslo 1/ročník V.

The Magazine is reviewed, volume 1/ V.

Address of the Editorial Office:

Civil Association
Education-Science-Research
Andrusovova 5
851 01 Bratislava,
Slovakia
vzv.esr@gmail.com

Pan European University, n.o.
Tematínska 10
851 05 Bratislava,
Slovakia
Phone: +421 2 68 203 639
dekanat.fi@paneurouni.com

Predplatné (Subscription):

Objednávky predplatného prijíma redakcia. Cena predplatného je 20 EUR na rok. Jednotlivé čísla možno objednať do vyčerpania zásob (cena 15 EUR za kus).

Subscription orders must be sent to the Editorial office. The price is 20 EUR a year. It is possible to order older issues only until present supplies are exhausted (15 EUR an issue).

Vydáva (Published by)

Pan-European University, Tomášiková 20, 821 02 Bratislava, Slovakia,

IČO: 36077429 in collaboration with the Civil Association EDUCATION-SCIENCE-RESEARCH, Andrusovova 5, 851 01 Bratislava, Slovakia, IČO: 42255180

Výroba (Production)

Voronezh Institute of High Technologies

Počet výtlačkov (Number of copies): 80 pieces, **ISSN:** 2453-7497(online) **ISSN:** 1338-6468 (print version), **EAN** 9771338646000 61

Evidenčné číslo (Registration No.): EV 4528/12

Elektronická verzia časopisu (Electronic version of Journal): <http://www.e-s-r.org>

Zadané do tlače (Delivered to the press): June 2016

Содержание / Contents

Предисловие / Editorial

Исследовательские работы / Research papers

- ▲ *Development of a hierarchical integrated enterprise management system with the use of the grai-gim and cimoso methodologies* 3
I. Lvovich, E. Lvovich
- ▲ *Modeling of dynamic organizational structures building process in enterprise management system of various orders*..... 14
E. Ružický, F. Schindler
- ▲ *Algorithmization of dynamic enterprise management structure building and target function of its development*..... 24
F. Schindler, V. Kostrova
- ▲ *Expert-optimization modeling of control actions choice and allocation of functions in dynamic organizational structures*..... 36
Martin Šperka, Juraj Štefanovič, Igor Lvovich
- ▲ *Modeling based on retrospective quantitative information processing via virtual expert resource*..... 54
J. Štefanovič, O. Choporov
- ▲ *Modeling of a numeracy of dominant options of multialternative optimization*... 61
I. Lvovich, J. Štefanovič
- ▲ *Modeling of multi-agent virtual expert competition for the use of expert virtual resource*..... 75
Y. Lvovich, E. Ružický
- ▲ *Algorithmization of interaction of components of expert virtual resource of procedural type in managerial decision-making optimization* 85
Y. Lvovich., O. Choporov, A. Preobrazhensky
- ▲ *The development of CAD of information systems and software for diffractive structures*..... 107
I. Lvovich, A. Preobrazhensky, O. Choporov
- ▲ *Modeling of scattering of electromagnetic waves on the base of multialternative optimization*..... 117
Y. Lvovich, A. Preobrazhensky, O. Choporov
- ▲ *Model decision rules to detect anomalies in information systems*..... 126
B. Akhmetov, A. Korchenko, N. Zhumangalieva, J. Kultan
- ▲ *Automation of the distribution process of sensitive data processing in a hybrid cloud computing environment* 137
A. Tsaregorodtsev, A. Zelenina

Информация / Information

- ▲ *Правила для авторов / Instructions for authors*..... 149

Предисловие / Editorial

.....
Dear readers!

This special issue of the journal is dedicated to the questions of rationalization of an enterprise activity management based on the modeling of dynamic network structures and decision-making support systems, as well as optimization of managerial decision making with the use of corporate intellectual capital. At the issue's core are the articles written by research scientists of Pan-European University (Bratislava, Slovak Republic), in collaboration with scientists of Voronezh Institute of High Technologies (Voronezh, Russia).

The subject matter of the represented works is related to the solution of a number of applied research tasks of current interest, including:

- Development of a hierarchical structure of integrated enterprise management;
- Modeling and algorithmization of the process of building dynamic network organizational structures in the object-functional management system;
- Expert and optimization modeling of the control actions choice and allocation of functions in dynamic organizational structures;
- Mathematical modeling, focused on decision-making with the use of expert and virtual resource of procedure type;
- Algorithmization of interaction of components of an expert and virtual resource of procedure type in optimization of managerial decision-making.

We hope that the published articles will attract attention of many researchers working in the field of information technology, and will be of interest for young researchers as well as recognized authorities in the field of using information technology for handling the problems of data mining, modeling, and management in various fields.

President of Voronezh Institute of High Technologies
D. Sc., Professor Yakov Lvovich



Development of a hierarchical integrated enterprise management system with the use of the grai-gim and cimosa methodologies

Igor Lvovich, Emma Lvovich

Abstract:

The issue of development of a hierarchical integrated system of production system management is considered. The main principles of enterprise management are defined. The interconnection between major management functions is represented in the form of the management cycle within the frame of the generalized system of enterprise management. The functional and processing approaches in enterprise management are analyzed and their advantages and disadvantages are defined. Special features of building of a hierarchical integrated management system (IMS) are identified. The feasibility of GRAI-GIM and CIMOSA methodologies using for building a dynamic organizational management structure within the IMS is investigated. The generalized model of the production system management, comprising a physical system, a production management system, and an integrated information system is introduced. The scheme of development of an integrated enterprise model according to the GIM - CIMOSA methodology is suggested.

Key words:

Enterprise management, hierarchical integrated management system, GRAI-GIM and CIMOSA methodologies, dynamic organizational structure.

ACM Computing Classification System:

User models, User studies, Usability testing, Heuristic evaluations, Walkthrough evaluations, Laboratory experiment.

■ Introduction

A modern enterprise represents an independent organizationally isolated national economy production sphere business unit, producing and selling goods, performing industrial works. One of the ways to solve the task of raising business efficiency is implementation of new technologies, meant to integrate isolated subsystems, uniting them

into an integrated system. Reaching this goal is possible only after building an effective enterprise management system.

Management's main task is providing growth of production efficiency on the basis of continuous enhancement of the technical level, management forms and methods, increasing productivity of the most important enterprise revenues gain and growth conditions [1-4].

1. Principles of enterprise management

Enterprise management is based on the principles, meant by governing codes and guidelines, taken as a basis for management problems solving. The most important principles of production management organization are:

- 1) objective compatibility and concentration principle;
- 2) continuity and reliability principle;
- 3) plan conformity, proportionality and dynamism principle;
- 4) the democratic principle of management functions distribution;
- 5) the management's scientific justification principle;
- 6) management efficiency principle;
- 7) the principle of personal, collective and state interests compatibility;
- 8) the principle of made decisions control and execution check.

The management process should be carried out on the basis of the system approach principles, as it represents the complex of many interrelated processes. Production systems management is intended to organize the personnel's activities, which allows reaching the set goals.

You have to take many decisions, performing planning, work organization, people's motivation, controlling and coordinating all the processes, taking place in the organization, in the course of management functions fulfilling. That's why management can be presented in organizational and technical systems as a sequence of functions, making up the management technological cycle. A management function means a stable harmonized assembly of operations, based on division of labor in the management system. Five main management functions are taken into consideration: prediction, organization, managerial activities, coordination (finalization) and control. At that all the functions are divided into six groups: production, finance, security, accounting, administration, safety engineering [5-8].

Along with this the following management system division criteria have been determined:

- by management essence, by virtue of which they are contained in every management task and altogether combine a closed management cycle;
- by management activity uniformity, defining the management labor differentiation (exact management functions);
- by the goal orientation uniformity (special management functions);
- by elementary managing impact forming orientation (management tasks);
- by management labor differentiation at its elementary managing work level.

The basic functions' correlation is presented in the form of a management cycle (fig. 1).

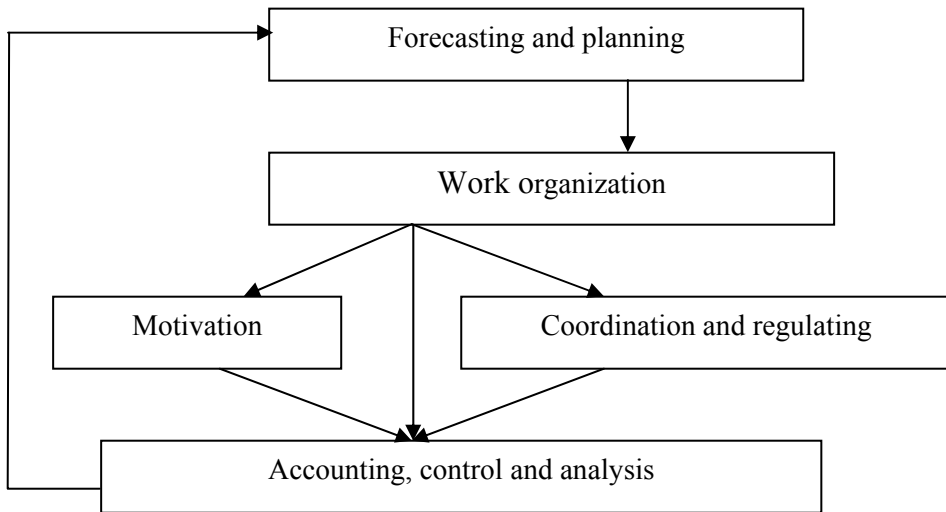

Figure 1. The management cycle, formed of general management functions

The set operation of an enterprise is provided by the management system, presenting a complex formation of processes and events, that can be perfected with different degree of detalization (fig. 2) [3, 4].

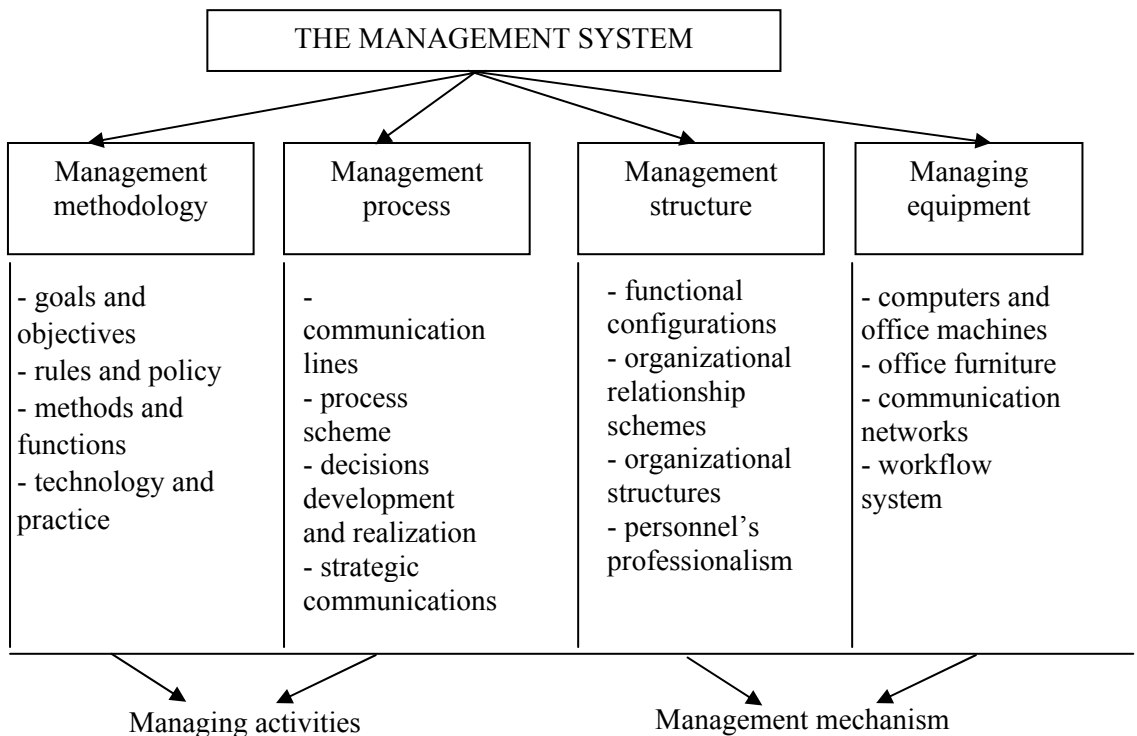

Figure 2. The generalized enterprise management system

2. Functional and processor approaches in enterprise management

Most of the existing enterprise management systems are based on the functional approach, considering an enterprise as a mechanism, possessing a set of functions. These functions are distributed among divisions between decision-makers (DMs). The enterprise's employees perform their highly-specialized duties without working to reach the enterprise's mission, as these functions may not be directed on reaching the final result. Structural subdivisions interact with each other, deal governing inputs, that take more time, than performing the work itself, which raise different disagreements between DMs [9-11].

The main disadvantages of the functional approach are the following:

- a functionally structured enterprise does not encourage employees' involvement in reaching the final result of the enterprise's activity. The employees' vision of the happening events most often doesn't go beyond the limits of their department, that's why they are not oriented on the enterprise's final targets, and especially on customers' satisfaction (with works, services);

- most of the technological business-processes of an enterprise includes lots of functions, i.e. go beyond the limits of specific departments. However, the exchange of information between different departments within functionally oriented structures is extremely complicated because of its vertical hierarchal pattern, which leads to large overhead costs, unreasonably long terms of managerial decisions making;

- big part of the time, necessary for realization of managerial impacts on production process, is spent on interactions between DMs and it's much longer than the time, necessary to realize the decision itself. This leads to great unreasonable delays in reaction to the disturbance input.

From the perspective of the processor approach an enterprise comprises of a set of processes. Business-processes follow through all departments and orientate on the enterprise's functioning final result. Every process has its own goal. You can reach high activity efficiency while managing processes if you establish strong horizontal links vertical structure of the enterprise management. The processor approach represents inner suppliers' and customers' «outcome» on a resourceful idea. In fact, real activity bringing added value, is not carried out by isolated elements of the functional hierarchy, but it penetrates the enterprise as an assembly of processes [1-4].

The processor approach allows to:

- consider such important aspects of business, as orientation on the final result of the enterprise's activity, commitment of every DM in raising efficiency of production in general and, consequently, commitment in high quality job performance;

- react to outer and inner changes more flexibly;

- optimize information exchange between functional departments;

- realize the most important idea of quality management: embedding quality control into the process instead of end product quality control.

When realizing processor approach:

- executives are given wide range of powers, increasing their role, independence and, consequently, effective output and labor satisfaction;

- managers are liberated from operational matters resolving and concentrate on strategic, system matters.

Thus, building an effective integrated enterprise management system supposes cooperation of both functional and processor approaches, realized within the framework of an object-functional enterprise management system [12-15].

▲ **3. Specific features of a hierarchical integrated management system building**

Enterprise management process is considered on two levels: goods (works, services) production process and the hierarchal administrative production process management superstructure. The first level represents technologic business-processes with the enterprise resources (technical and process, material, labor, informational, financial) as an income and having end product, performed works or rendered services as an outcome. The second level of representation administrative business-processes are realized, including:

- studying of suppliers' and customers' markets;
- widening conceptualization and strategy;
- designing products and services;
- enterprise resource management;
- outer links management;
- improvements and changes management.

An enterprise's production activity in a relatively stable outer environment supposes building a system of administrative business-processes on the basis of the planned technologic business-processes, carried out at the enterprise projecting stage. However, the market's requirements to the product quality are being raised, order execution time is lowered, the output product stock list is changing, which realigns the enterprise functioning process significantly. This leads to changes in technologic business-processes and information database contents change, while changing management objects' properties changes the contents and the quality of DM functions, as well as the information interlink system.

Technologic and administrative business-processes influence:

- the structure and the contents of the information database;
- the interaction between DMs in correspondence with their functions, responsibility and rights;
- the management objects and their properties.

In its turn, changing management objects' properties influences DM functions, the contents of the database and the administrative business-processes [4, 5].

In order to provide the most rational real-time reaction of an enterprise to disturbing factors it is efficient to use an integrated management system (IMS) building methodology, aimed for the enterprise management system structuring to provide forming and effective functioning of a dynamic organizational management model. This methodology is based on the following statements (fig. 3):

1. Creation of united informational managerial decisions and governing inputs space.
2. Exception of duplicate information flows and, consequently duplicate management functions.
3. Management functions decentralization and redistribution of responsibility for the enterprise's resources while performing managerial tasks.

4. Forming regulations of the enterprise's resources creation, using and storage in the integrated database.
5. Tracking information lifetime cycle stages to perform the strategic enterprise management tasks.
6. Forming enlarged factors for the enterprise's current state evaluation, business development forecasting.
7. DMs' labor motivation for timely and high-quality managerial actions within the limits of delegated powers and the rights to use the enterprise's resources, given to them.

An important peculiarity of IMS is the dynamic projection of new informational links, changing depending on the solved managerial tasks' specific contents on the enterprise's existing organizational-production objects management functions.

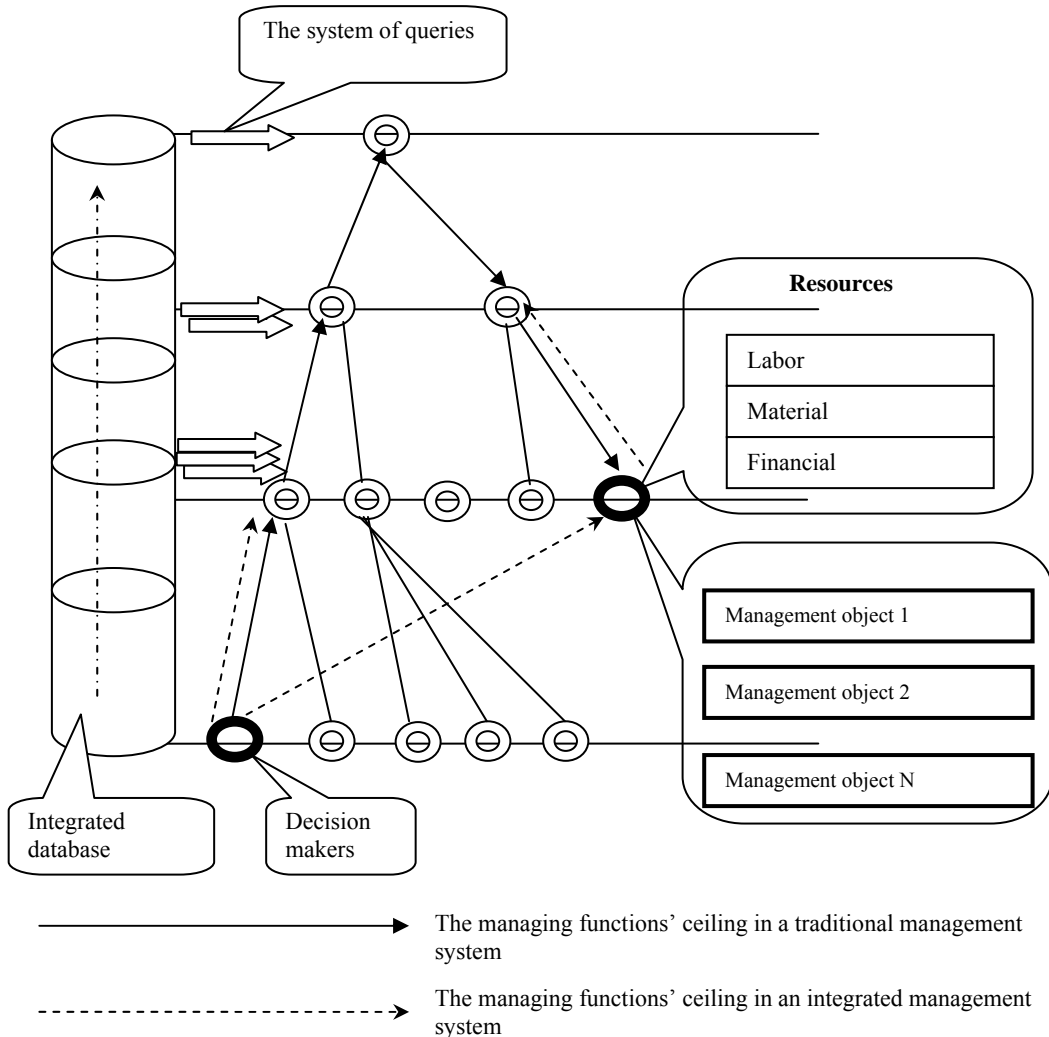

Figure 3. The integrated management formation scheme

Thus, while performing a specific managerial task the management system hierarchy stays the same, but the informational structure of the managerial decisions taking process changes. The system of distributing rights on information queries

depending on the task being solved allows to build variants of DMs' network interaction with management objects in accordance with the corresponding functions set.

That's why an IMS enables you to take effective managerial decisions not so much by means of computer network information transmission speed increase, as by means of the management system's strategic reaction to inner and outer disturbing factors [1, 10, 15].

IMS differs from the existing enterprise management systems by the following parameters:

1. Efficient functioning in the changing outer and inner environment conditions.
2. It allows to take managerial decisions in real time according to the developed enterprise business-processes regulations.
3. It provides a formalized distribution of rights, duties, responsibility and the enterprise's resources between DMs.
4. It allows to solve non-typical situations, caused by deviations from business-processes' normal course without conflicts.

▲ **4. Application of GRAI-GIM and CIMOSA methodologies for building a dynamic organizational structure of management within the framework of an integrated management system (IMS)**

It is suggested to build a dynamic organizational management structure within an IMS using the GRAI-GIM and CIMOSA methodologies, which allow exploring and designing a production management system and performing the process of managerial decisions taking.

The generalized production system management model consists of the following components (fig. 4):

- a physical system,
- a production management system,
- an integrated informational system.

A management system consists of a hierarchal structure, decision making centers, containing all decision making functions on the set hierarchal level. Such an enterprise hierarchal structure makes the information system hierarchal as well.

Information from the physical system and from the environment is filtered, integrated and supplied for using to every decision making center of the hierarchal enterprise management system.

The management system, that composes decision making variants and the information system, which regulates the physical system, enable reaching the production goals. The most important property of a management system is the function of acquiring information directly from the integrated database in real time mode. The GRAI method's modularity consists in production management processes description formalization, aimed for maintaining the dialogue and information exchange between the management process participants.

GRAI-GIM contains a technological and administrative business-processes description method in the context of functions, information, decision making system and using different kinds of resources. The decision making system determines the patterns of the material and the information systems' behavior in order to transmit, process and remember the necessary information.

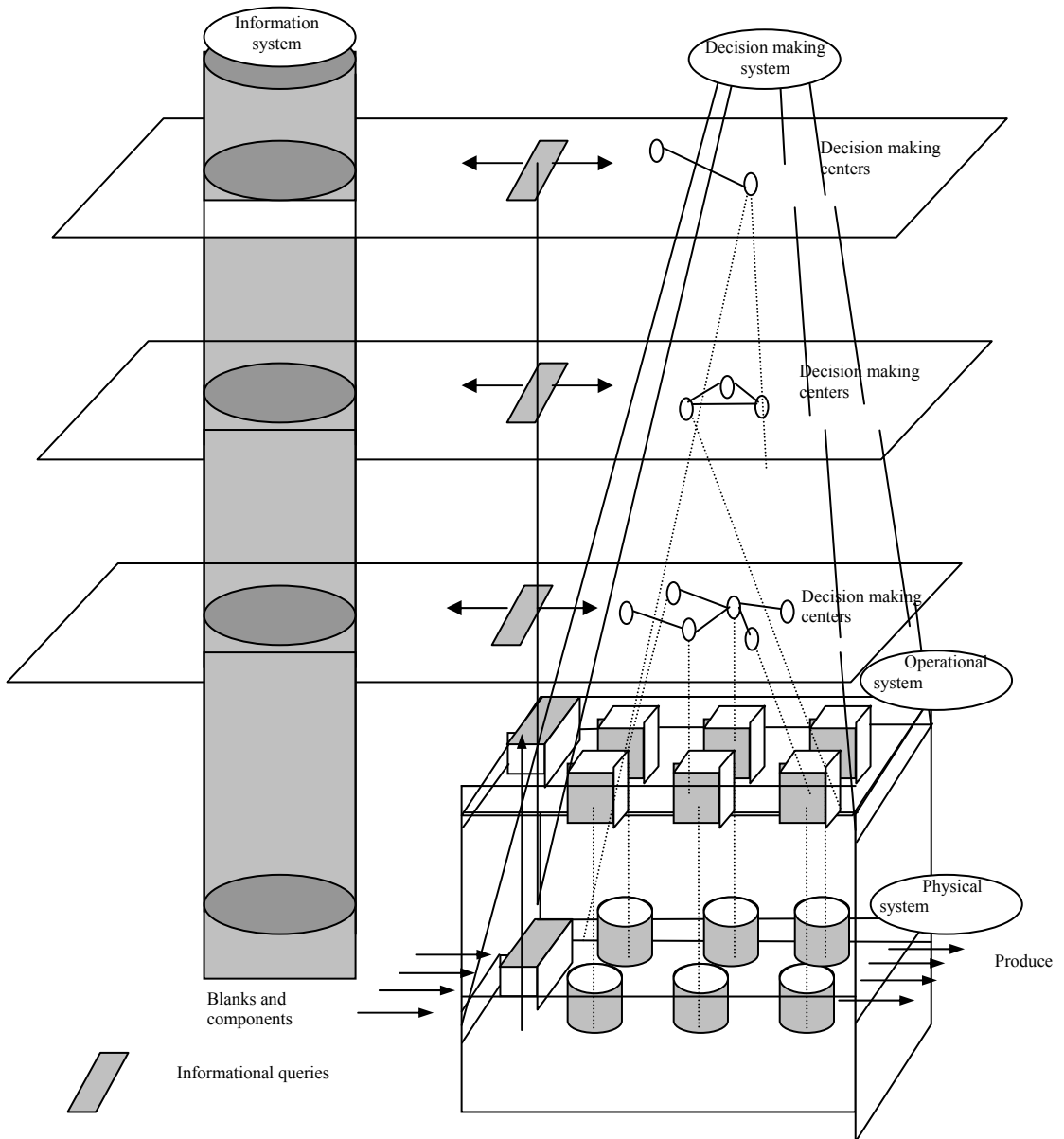

Figure 4. The production system management model

The CIMOSA methodology allows using the enterprise model for planning and strategic management. Reaching this goal is encouraged by developing of two components: the enterprise model being carried out and the integrated production infrastructure. The enterprise model is presented as a multidimensional space, the so-called CIMOSA cube (fig. 5).

The integrated enterprise model creation process is carried out by the used on three modeling levels:

- determining business requirements for the enterprise;
- transparent process optimization;
- the project's technical specifications.

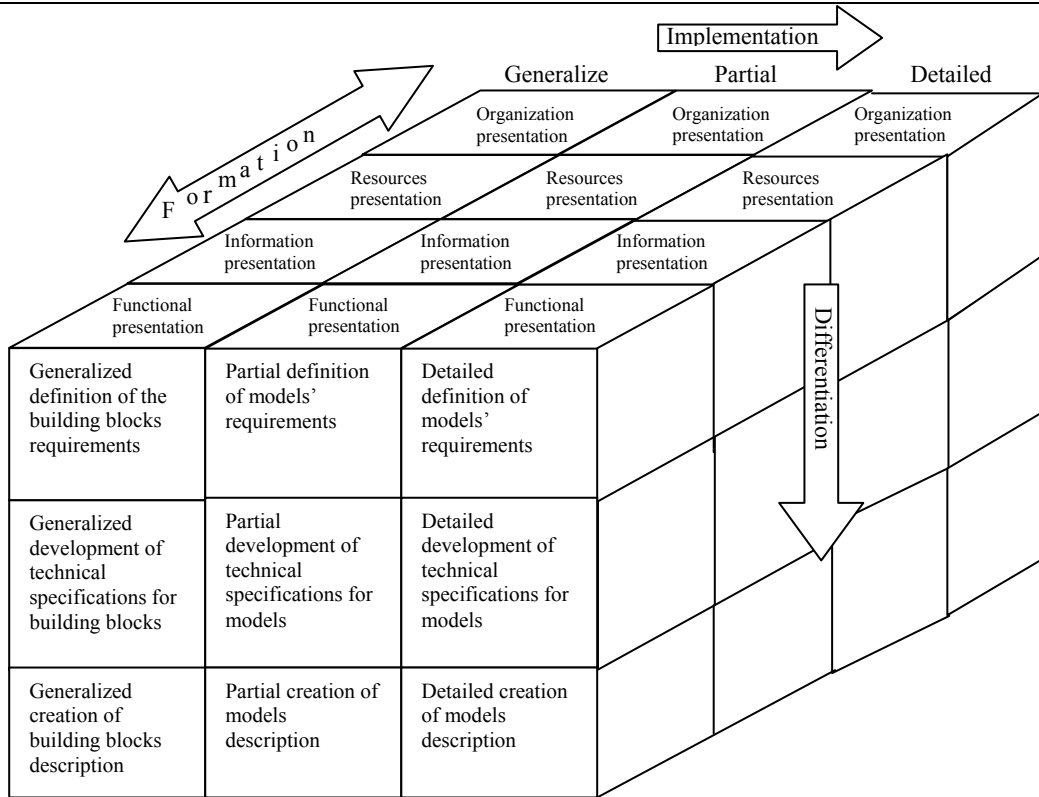

Figure 5. CIMOSA methodology presentation

During modeling process the enterprise is analyzed on every level regarding different user's presentations considering the fact that these levels may be present on all lifetime cycle stages, related to creation of any processes. Each of the levels is represented in four planes (Fig. 6.), where the following are realized:

- functional presentation (action sequences are described);
- informational presentation (functions inputs and outputs are described; data model is described);
- resources presentation (material, labor, technical and process and informational resources structure is described);
- presentation of an organization as a system of authorities and duties.

The corresponding structures are designed within the CIMOSA methodology in a way that they are mostly suitable for computer processing and provide their maximum efficiency. In order to support this requirement, two environments have been designed, in which:

- the developer, designing an integrated enterprise, formalizes enterprise models designing and performs their adaptation to working in computer enterprise management systems;
- the enterprise's operational environment formalizes checking, testing and acceptance of the following programs to the enterprise management informational managing system.

These environments have sets of formal functions, which enable to carry out integration of infrastructure and provide enterprise management system flexibility and its independence from the project's developer.

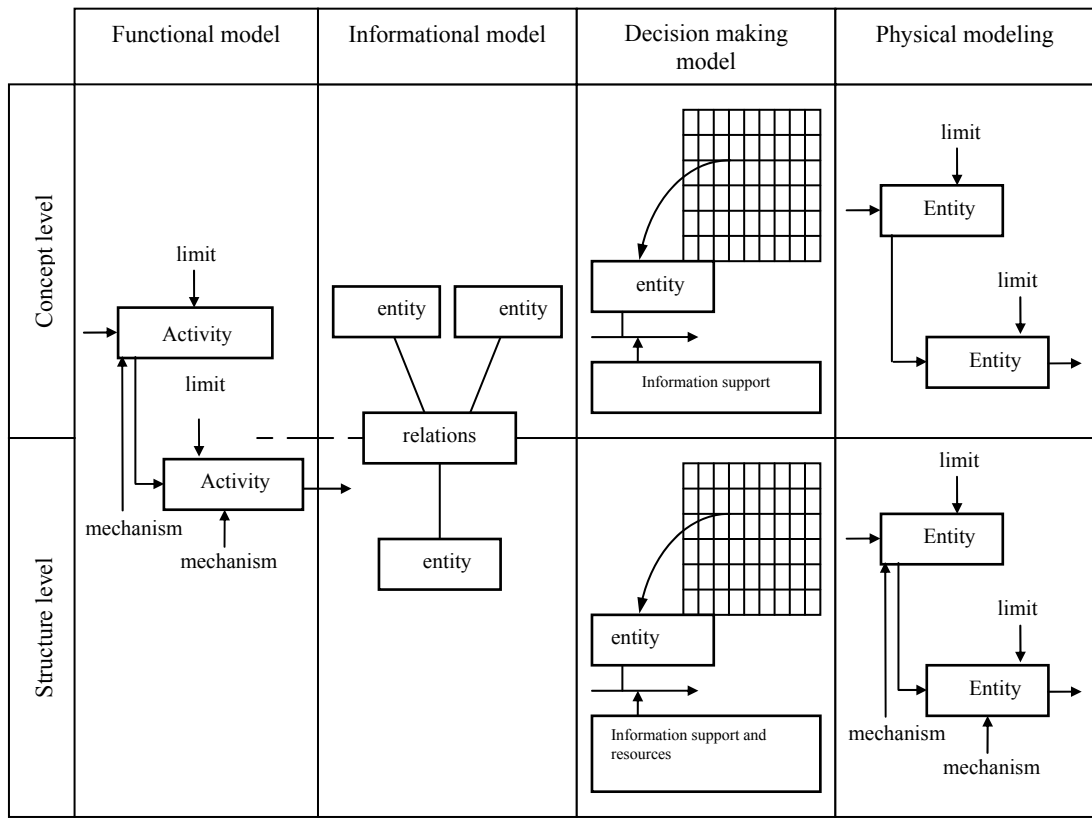

Figure 6. The integrated enterprise model designing scheme in correspondence with the GIM – CIMOSA methodology

Conclusion

Therefore, as a result of this study the analysis of organizational structures building methods development tendencies, aimed at raising the efficiency of modern enterprise business-processes management systems, has been carried out; a model of an integrated enterprise management system, notable for dynamic projection of new information links, changing depending on specific contents of the managerial tasks being solved on the existing enterprise organizational-production objects management functions, has been suggested.

References

- [1] SPERKA M. 2015. Special aspects and principles of identification of objects with inhomogeneous characteristics In: *Information Technology Applications*. Bratislava: PEVS-VVV, 2015. ISSN 1338-6468, no. 1, p. 3-12.
- [2] SCHINDLER F. 2015. Algorithmization of decision-making in management of objects with inhomogeneous characteristics In: *Information Technology Applications*. Bratislava: PEVS-VVV, 2015. ISSN 1338-6468, no. 1, p. 13-22.
- [3] LVOVICH I. Structurization of an expert and virtual resource of the corporate

- intellectual capital in the environment of adoption of administrative decisions. In: *Information Technology Applications*. Bratislava: PEVS-VVV, 2015. ISSN 1338-6468, no. 1, p. 23-32.
- [4] RUZICKY E. 2015. Formalization of user interaction with virtual expert resource of knowledge type via ontological modelling. In: *Information Technology Applications*. Bratislava: PEVS-VVV, 2015. ISSN 1338-6468, no. 1, p. 23-32.
- [5] PREOBRAZHENSKY Yu. P. 2010. The wording and classification of problems of optimal control production facilities In: *Bulletin of Voronezh State Technical University*, 2010. vol. 6, no. 5, p. 99-102.
- [6] CHOPOROV, O.N., CHUPEEV, A.N., BREGEDA S.Y. 2008. Significance Methods of analysis parameters in the classification and predictive modeling In: *Bulletin of Voronezh State Technical University*, 2008. vol. 4, no. 9, p. 92-94.
- [7] MOSKALCHUK, Yu. I., NAUMOVA, E. G., KISELEVA E. V. 2013. Problemy optimization of innovation processes in organizations In: *Simulation, optimization and information technology*, 2013. no. 2, p. 10.
- [8] GUSKOVA, L. B. 2012. On the construction of the automated work place manager In: *Successes of modern science*, 2012. no. 6, p. 106.
- [9] RODIONOVA, K. Y. 2012. Globalization of the world economy: the nature and contradictions In: *Herald of the Voronezh Institute of High Technologies*, 2012. no. 9, p. 185.
- [10] SHISHKINA, Y. M., BOLUCHEVSKAYA, O.A. 2011. Public administration In: *Recent studies of social problems*, 2011. vol. 6. no. 2, p. 241
- [11] PENKOV, P. V. 2012. Expert methods to improve control systems In: *Herald of the Voronezh Institute of High Technologies*. 2012. no. 9, p. 108
- [12] RYAZHSKIY, A. M., PREOBRAZHENSKY, Yu. P. 2008. Construction of stochastic models of business processes optimization In: *Herald of the Voronezh Institute of High Technologies*. 2008. no. 3, p. 79.
- [13] KOROLKOV, R. V. 2013. Controlling the trade organization In: *Herald of the Voronezh Institute of High Technologies*. 2013. no. 10, p. 287.
- [14] LISSITZKY, D. S., PREOBRAZHENSKY, Yu. P. 2008. Building a simulation model of socio-economic system In: *Herald of the Voronezh Institute of High Technologies*. 2008. no. 3, p. 135-136.
- [15] SAMOYLOVA U. A. 2014. Some characteristics of the enterprise management. In: *Herald of the Voronezh Institute of High Technologies*. 2014. no. 12, p. 176

Prof. Igor Lvovich, Dr. of Sc.

Pan-European University, Bratislava, Slovakia
office@vivt.ru

Docent Emma Lvovich, Cand. of Econ. Sc.

Russian New University, Moscow, Russia
office@vivt.ru



Modeling of dynamic organizational structures building process in enterprise management system of various orders

Eugen Ružický, Frank Schindler

Abstract:

The three types of control: closed loop control, open-loop control and isolation control are introduced from the standpoint of rational manufacturing enterprise management. The problem of building a dynamic enterprise management structure is defined. The six levels of detail of the business processes integrated management system (IMS) are suggested for the implementation of the above-mentioned challenge. For a more detailed representation of the IMS elements functionality, the aggregation-decomposition approach is proposed in the work. It represents the system as a set of interrelated elements of different level of detail. To formalize the relationships between the variations of the ISU elements building, the alternative-graph formalization is suggested. The mathematical model of interaction between a decision maker (DM), objects of control and business processes, based on the Petri nets apparatus is developed.

Keywords:

Enterprise management, dynamic organizational structure, network management structure, aggregation-decomposition approach, modeling, Petri nets.

ACM Computing Classification System:

Cloud computing, Client-server architectures, n-tier architectures, Peer-to-peer architectures, Grid computing.

■ Introduction

The task of manufacturing enterprise sustainable governance remains a live issue today on both practical and theoretical grounds.

There are three management types: closed-loop management, open loop management, and isolated management. If a management subsystem belongs to the management

system, its activity and development control is carried out in a closed loop by means of the system's output feedback with input. The presence of the feedback provides an impact on production factors by means of their own resources, which allows to reach the production system self-organization. There's no feedback between the output and the input in the open loop management. The isolated management is reached by organizing input and output filters, preventing undesirable inputs to enter the system from the outer environment and undesirable outputs to exit the system to the outer environment.

All the three management schemes are combined in real enterprise management systems. The correlation between closed-loop and open loop management changes depending on the enterprise's legal organizational forms.

Management types are stipulated by using different means of the management system, which is a variable quantity. It is common to determine the programme, the supervisory, the adaptive and the extreme management types [1-4].

In the programme management the management programme is determined in time. This is the most widely used management type for an enterprise in general, as the productive capacity is planned in connection with the calendar.

In the supervisory management the management programme depends not on time but on some leading (supervisory) value. An essential condition for using supervisory management is good organization of the supervisory value study and prediction works, allowing to reorganize production timely. Conversely, the necessity of timely production reorganizing depending on the supervisory value requires perfecting of the production organization and technology in the line of their flexibility raise.

When adaptive management is used, there's no determined supervisory value and the management sets the programme on the basis of prior experience. That's why accumulation and summing up conclusions from prior experience are mandatory conditions of adaptive management.

When extreme management is used, the management programme is aimed for reaching some function's maximum or minimum, with any given parameters being set as variables (input, the state of the controlled system or output). Extreme management can be realized with a limited level of outer environment stability [5-7].

Most often production systems management has complex character combining all four management types.

The management process should be carried out on the basis of the system approach principles, as it represents the complex of many interrelated processes.

You have to take many decisions, performing planning, work organization, people's motivation, controlling and coordinating all the processes, taking place in the organization, in the course of management functions fulfilling. That's why management can be presented in organizational and technical systems as a sequence of functions, making up the management technological cycle [8-10].

The task of building an effective management structure comprises of an optimal choice: interaction between DMs; variants of realization of management functions (goals), business-processes and their distribution between management objects. However, completing this task is possible for a specific set perspective time period and for some set system functioning conditions. The management system's strategic reaction to the outer environment's disturbing inputs assumes completion of the dynamic effective management structure designing task. Such a task optimizes not only the structure of management objects, DMs and interlinks between them, functions distribution for the given moment of time but also suggests the variants of the system functioning in force-majeure conditions.

Management systems functioning process may include a variety of aspects, representing a stage when specific goals are set for the system and it has to reach them. That's why the management system structure must be designed in way to react to the disturbing inputs adequately. Therefore, the dynamic goal of building an effective management structure consists in the choice such an array of management objects, DMs, interrelations between them and such distribution of functions and responsibility for the resources on each business-process, that the requirements to the system's quality characteristics would be met on every moment of its functioning [11].

1. Development of a model of a dynamic network management structure

Solving the dynamic enterprise management structure designing task is realized on six levels of integrated management system (IMS) detalization by business-processes. On the top level the goals, realized by IMS, are formalized, then the performed management functions and goals, which can be detalized to separate technological and administrative business for each DM are formalized.

The generalized task of an enterprise management system building in the conditions of an integrated management system can be represented with the following set of information:

$\langle A, B, C, D, F, G, K, W \rangle$,

where A represents – the tree of IMS' goals;

B – the variety of tasks, resolved by IMS;

C – the array of management functions, realized in IMS;

D – the array of management objects;

F – the array of administrative business-processes;

G – the assembly of DMs, forming management hierarchy;

K – the array of choice criteria (in accordance with the enterprise's regulations);

W – the array of acceptable alternative variants of the dynamic management structure, realized in IMS.

The mechanism of building a dynamic network management structure within the framework of an IMS to choose a rational managerial solution from the array of acceptable alternative variants in order to reach the set goals, is chosen in accordance with the criteria, set at the enterprise. The dynamic management structure model will be as follows:

$$W_i = \bigcup_{i=1}^G (A_i B_i C_i D_i F_i) . \quad (1)$$

In order to reflect the links between the elements in the IMS the integrated enterprise model in three dimensions (fig. 1) is used, where the following are realized:

- IMS management structures business-processes lifecycle;
- Enterprise presentation as a hierarchal organizational structure, reflecting DMs' powers and responsibility with regard to management functions;
- IMS management objects presentation with regard to their properties.

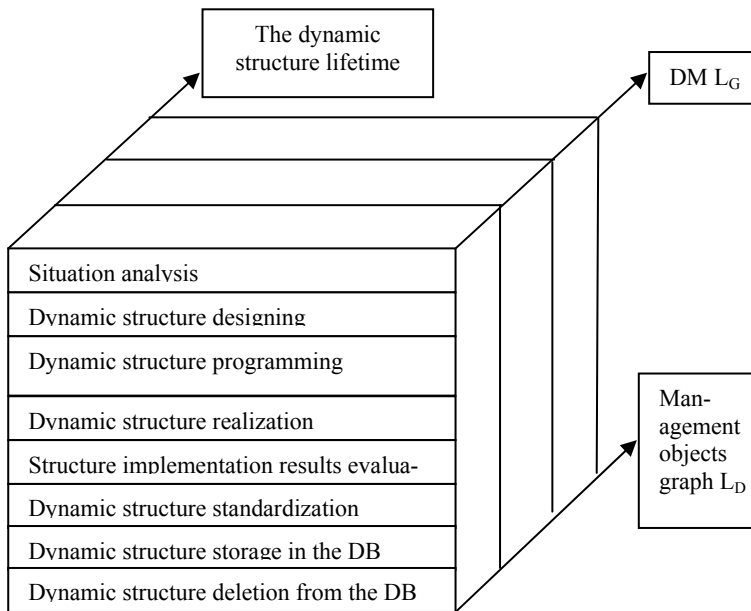

Figure 1. Presentation of interlinks between IMS elements with business-processes

2. The aggregation-decomposition approach for IMS elements modeling

In order to reflect the interlinks between IMS elements the aggregate-decomposition approach, consisting in the system's presentation as an array of interlinked elements of different detalization levels, is used in the work. In order to formalize interlinks between different variants of IMS elements building the alternative-graph formalization, in which different management system elements (or such elements' arrays) building variants are set as an alternative graph node and the arcs reflect the character of relations between them, is used [12-14].

The aggregate-decomposition approach includes two related stages:

- the sequential decomposition of the functions, goals, business-processes, carried out by the system;
- aggregation of elements on the corresponding detalization level to generate variants of building correlations in the management system in general on the considered detalization level.

In order to solve the dynamic network organizational structures in an object-functional enterprise management system it is necessary to build the following graphs:

- the L_A graph sets correlations of the alternative variants of management goals reaching;
- the L_B graph sets alternative variants of management tasks fulfillment;
- the L_C graph sets alternative variants of management functions realization;
- the L_D graph reflects correlations between management objects;
- the L_F graph reflects variants of administrative business-processes realization, regarding technologic ones, and it can be detalized to separate business-processes' and aggregates' stages;

- the L_G graph determines DM hierarchy and possible correlations between them while managerial decisions realization [15-17].

Typical system parts are separated during business-processes level aggregation. Aggregation on the tasks level leads to separation of typical tasks and aggregation on higher levels allows to determine the system's aggregated functions and its goals.

In order to solve the task of a dynamic management structure building it is necessary to determine every detailization level as classifiers:

$$L_A = (A, N), \text{ where } A = \{A^0, A^1, \dots, A^{G-1}\} \quad (2)$$

$$L_B = (B, M), \text{ where } B = \{B^0, B^1, \dots, B^{G-1}\} \quad (3)$$

$$L_C = (C, Z), \text{ where } F = \{C^0, C^1, \dots, C^{G-1}\} \quad (4)$$

$$L_D = (D, X), \text{ where } D = \{D^0, D^1, \dots, C^{G-1}\} \quad (5)$$

$$L_F = (F, Y), \text{ where } F = \{F^0, F^1, \dots, F^{F-1}\} \quad (6)$$

Let ϖ be an operation of array elements displaying. The optimal displaying should provide some target function (functions') extreme point in case of set limits adherence.

The generalized network management system building task is described by the following definition:

$$A \in n; \quad (7)$$

$$c \in C(A); \quad (8)$$

$$D \in \overline{D}; \quad (9)$$

$$[c \in C(A)]\varpi[D \in \overline{D}]. \quad (10)$$

If technologic processes and the management system objectives tree are set, then the dynamic structure building task lays in the (7)-(10) definition; if technologic processes, the system's objectives tree, the performed management functions and the array of management objects are set, then it lays in the (10) definition.

Solving the dynamic management structures building task is closely related with the problems of distributing functions, responsibility for the enterprise's resources with a permanent set of management objects, DMs, management levels number. That's why there's the necessity of solving the dynamic management structure building task, including the choice of an IMS functioning principles and algorithms. In general case these problems are interrelated, because if you change the structure the system of target functions and inner links also changes and, consequently, the system of the system's elements' behavior also changes [1-4].

It is possible to point out the following directions of dynamic management structures building:

- building a structure with set system functioning algorithms and functions;
- synthesis of functioning algorithms, functions, the rules of DM behavior and their interactions within the set hierarchal system;
- building a management structure, including both management system functioning optimization, and functions distribution along IMS nodes and their contents choice.
- Solving the third goals unit is suggested using the aggregate-decomposition approach. Depending on the level of detailization of the tasks, functions and goals performed by the system and on their displaying by IMS levels the following typical management structure building task settings can be used:

- the optimal displaying of the tree of objectives, performed by the system (the L_A graph) on the hierarchal organizational management system (the L_G graph); the array of

DMs and their correlations are mainly determined by peculiarities of the system objectives graph;

- the optimal displaying of the array of functions, tasks, performed by the system, management objects (the L_C, L_B, L_D graphs) on the DMs array (the L_C graph) regarding the peculiarities of the L_F graph;

- optimization of the administrative business-processes contents and realization variants and DMs' (the L_F and the L_G graphs) during the managerial decisions taking process.

The dynamic management structure building task consists in the directed DMs choice from the array of management objects $\{D\}$ of such an assembly of $D_C \in D$ elements, that would provide performing the array of the function system elements $\{C\}$. The management objects array concept design model can be presented as follows:

$$C^G \rightarrow \theta^G \rightarrow D_{\varphi\varphi}^G = \sum_{i=1}^t D_{\varphi\varphi}^G \in D^G, \tag{11}$$

where ψ is the alternative network management structure variant index; $0 \leq \psi \leq V$, V is the alternative network structure variants quantity;

θ is the correlation of management elements arrays and management functions.

Using the procedure of choice the array of alternative network management structures array is formed inside the D^G array following the θ^G links in IMS circumstances for every DM – W_{ψ}^G . The task of a DM is choosing a rational scheme of relationship while taking managerial decisions using the following parameters:

$$W_{\psi}^G(S_C^G) \in W_{\psi}^G, \tag{12}$$

where S is the range of dynamic management structures within the IMS framework.

The mechanism of dynamic network management structures building within an IMS is presented on figure 2 [1, 12-14].

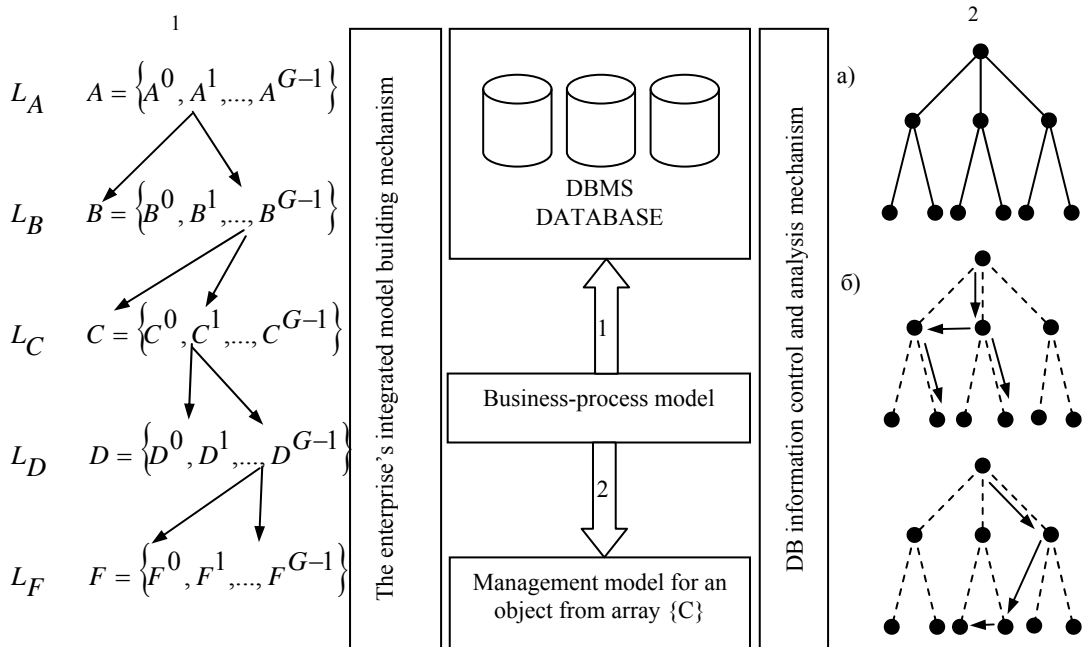

Figure 2. The mechanism of dynamic management structures building within an IMS by business-processes

Legend:

I. – Enterprise presentation as graph-arrays

II. a) the LG array,

b) variants of dynamic management structures for a managerial decision realization.

1 – data modeling

2 – management functions modeling.

► **3. The mathematical model of interaction between a decision maker (DM), objects of control and business processes, based on the Petri nets apparatus**

The mathematic model of interaction between DMs, management objects and business-processes is built using the Petri net apparatus. When building a Petri net positions can be displayed as DMs as well as situation analysis state; and the transitions can display both managerial decisions and messages about some events. In order to reflect a complicated transition in the network an element is used, which considers an assembly of inner situations while taking managerial decisions about the transition from one DM to another. The contents of positions and transitions in Petri nets reflects the sequence of taken managerial decisions and functional connections between DMs rather fully (fig. 3).

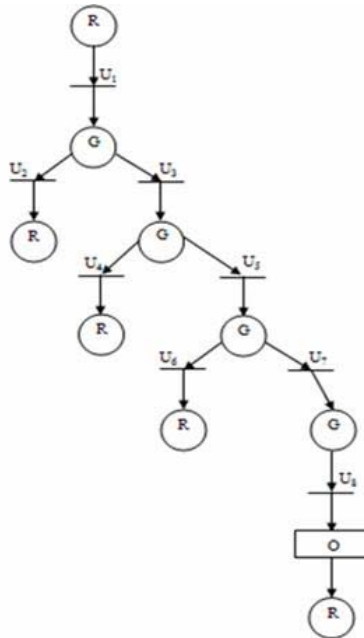

Figure 3. Petri net of an integrated enterprise management system building

Legend:

$G_1 - G_4$ – DMs, an entity from the $\{G\}$ array,

R – the customer

O – an element of time interval, equal to the order realization time, from the start of production to being given to the customer

$U_1 - U_8$ – managerial decisions, an assembly from the $\{F\}$ array.

While building a Petri net the following conditions have to be considered:

1. Interaction between IMS and outer environment, as well as between elements within the IMS is carried out by means of signal transmission, the mutual influence, performed outside the signal exchange mechanism, is not considered.
2. An input for any IMS represents an assembly of input information; the information flow is meant for receiving elementary signals $x_i(t) < X, i = 1, n$. The same way managing and output information flows are input.
3. The outer environment is reviewed as some aggregate, characterized by the assembly of input and output signals.
4. Elementary signals, transmitted by a specific output information flow, can be transmitted to a specific input or managing informational flow in case if an individual elementary data transmission channel, connecting the stated information flows, is realized in the system.
5. Each input and managing information flow is connected by not more than one individual channel. Every output information flow can be connected by any end number of individual channels in case that the input and the managing input of every IMS element is directed by not more, than one of these channels.

The structure of links between IMS elements and the outer environment is determined by the assembly of individual channels, realized in reality.

Thus, building correlations between IMS elements regarding the stated rules and realization of managerial decisions making processes within the framework of Petri nets, regulated by the enterprise standards, allows to avoid conflicts during business-processes.

The correlations of the assembly of integrated enterprise management systems' aims, tasks being solved, management functions, management objects, DMs can be represented as matrixes. Thus, the correlation of the management functions array and the management objects is represented by the $A = \| a_{ij} \|$ matrix, where the a_{ij} value determines the efficiency of the j management function's managerial impact on the i management object.

The same way management objects array interaction matrix with the DMs array and management tasks array interaction matrix with the management functions array are built.

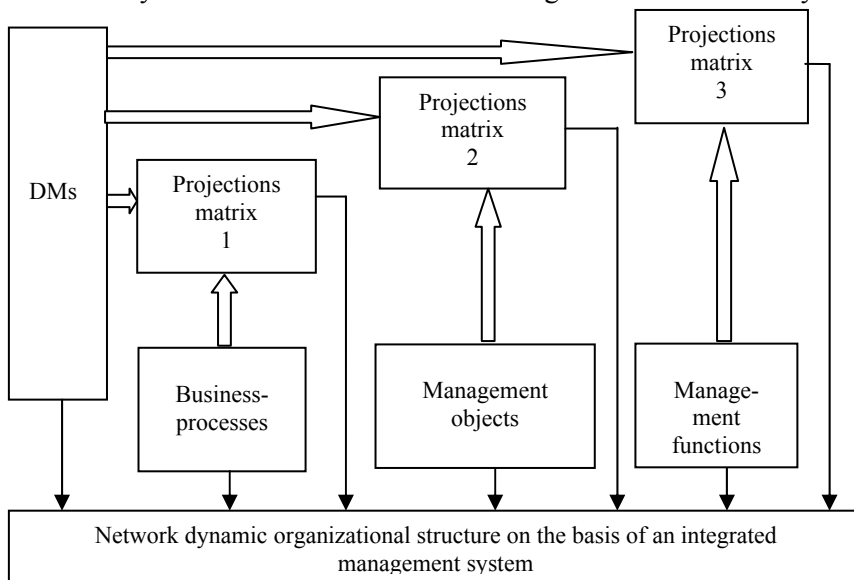

Figure 4. Building dynamic management structures within the framework of an integrated management system

Conclusion

Therefore, as a result of this study a model of interaction between an integrated management system elements, providing realization of managerial decisions making processes within the framework of the Petri nets, approved by the enterprise's standard, has been designed.

References

- [1] SPERKA M. 2015. *Special aspects and principles of identification of objects with inhomogeneous characteristics*. In: Information Technology Applications, ISSN 1338-6468, no 1, p. 3-12.
- [2] SCHINDLER F. 2015. *Algorithmization of decision-making in management of objects with inhomogeneous characteristics*. In: Information Technology Applications, ISSN 1338-6468, no 1, p. 13-22.
- [3] LVOVICH I. 2015. *Structurization of an expert and virtual resource of the corporate intellectual capital in the environment of adoption of administrative decisions*. In: Information Technology Applications, ISSN 1338-6468, no 1, p. 23-32.
- [4] RUZICKY E. 2015. *Formalization of user interaction with virtual expert resource of knowledge type via ontological modelling*. In: Information Technology Applications, ISSN 1338-6468, no 1, p. 23-32.
- [5] PREOBRAZHENSKY Y. P. 2010. *The wording and classification of problems of optimal control production facilities*. In: Bulletin of Voronezh State Technical University, ISSN 1994-1730, vol. 6, no 5, p. 99-102.
- [6] CHOROPOV O. N. 2008. *On significance Methods of analysis parameters in the classification and predictive modeling*. In: Bulletin of Voronezh State Technical University, ISSN 1994-1730, vol. 4, no 9, p. 92-94.
- [7] MOSKALCHUK Y. I. 2013. *Problemy optimization of innovation processes in organizations*. In: Simulation, optimization and information technology, no 2, p. 10.
- [8] GUSKOVA L. B. 2012. *On the construction of the automated work place manager*. In: Successes of modern science, no 6, p. 106.
- [9] RODIONOVA K. Yu. 2012. *Globalization of the world economy: the nature and contradictions*. In: Herald of the Voronezh Institute of High Technologies, no 9, p. 185-186.
- [10] SHISKINA Y. M. 2011. *Public administration*. In: Recent studies of social problems, vol. 6, no 2, p. 241-242.
- [11] PENKOV P. V. 2012. *Expert methods to improve control systems*. In: Herald of the Voronezh Institute of High Technologies, no 9, p. 108-110.
- [12] RYAZHSHIH A. M. 2008. *Construction of stochastic models of business processes optimization*. In: Herald of the Voronezh Institute of High Technologies, no 3, p. 79-81.
- [13] KOROLKOV R. V. 2013. *Controlling the trade organization*. In: Herald of the Voronezh Institute of High Technologies, no 10, p. 287-290.
- [14] LISITSKY D. S. 2008. *Building a simulation model of socio-economic system*. In: Herald of the Voronezh Institute of High Technologies, no 3, p. 135-136.
- [15] SAMOYLOVA U. A., 2014. *Some characteristics of the enterprise management*. In: Herald of the Voronezh Institute of High Technologies, no 12, p. 176-179.

- [16] KOROLKOV R. V., 2013. *On the financial management of the organization*. In: Herald of the Voronezh Institute of High Technologies, no 11, p. 144-147.
- [17] KRAVTSOV D. O., 2008. *Methods of optimal control of socio-economic system based on the adaptation*. In: Herald of the Voronezh Institute of High Technologies, no 3, p. 133-134.

Doc. RNDr. Eugen Ruzicky, CSc.

Pan-European University, Bratislava, Slovakia
eugen.ruzicky@paneurouni.com

Prof. RNDr. Frank Schindler, Ph.D.

Pan-European University, Bratislava, Slovakia
frank.schindler@paneurouni.com



Algorithmization of dynamic enterprise management structure building and target function of its development

Frank Schindler, Vera Kostrova

Abstract:

One way to improve an enterprise operation efficiency is to improve its control system. To solve this problem based on the analysis of the main approaches to the development of enterprise management structure and organizational structure design principles, an algorithm for building a dynamic management structure in conditions of the business processes integrated management system (IMS), and an algorithm for building a target function of its development are proposed. The first algorithm consists of 11 consecutive steps. Its functioning in real time is performed via the decision-maker query system to the enterprise integrated data base. The second algorithm is based on the building of a resultant set of performance indicators of a single criterion with an application of the axiomatic and adaptive approaches. The developed algorithm is based on the expert information and provides accounting of the quantitative prognostic assessments of enterprise business processes.

Keywords:

Dynamic management structure, organizational structure, target function of enterprise development, business process, expert methods, adaptive approach.

ACM Computing Classification System:

Cloud computing, Client-server architectures, n-tier architectures, Peer-to-peer architectures, Grid computing

▀ Introduction

An organizational structure creates conditions for the enterprise's activity performance and reaching the set objectives. It develops and changes influenced by the peculiarities of the enterprise's strategy, its inner complication and changes of the outer environ-

ment. There's a wide range of structures, stretching from stable monolithic formations to dynamic monolithic formations of modern organizations [1].

Material and economic elements of an organization's structure and the process, that take place in it are inseparably associated and they organize the unity of its static and dynamic characteristics.

If you consider an enterprise as a management object you can singularize the following directions of its integration:

- management methodology: policy, mission, goals, principles, methods, enterprise functioning technology;
- management process: communication lines, elaboration, realization, managerial decisions' technical support;
- enterprise management structure;
- functional, organizational structures, human element;
- enterprise integration process technical support.

The integration process represents uniting all subsystems into one banded system. Whereby the methodological basis for an enterprise integration are system analysis methods, used in enterprise management system perfecting, new organizational management forms designing and modeling.

It's important to pay attention to the process of changing the management style from authoritarian to democratic during an enterprise management systems integration. This leads to the evolution of management systems from the bureaucratic model, which is a strictly regulated system, to the dynamic model. One of the evolution factors is management decentralization. Decentralization means delegation of authorities to lower levels, which encourages better functionality of managers' activities. Decentralization practice in administration structures indicates its different advantages. Firstly, it activates development of managers' professional skills, which raises their responsibility for decision making. Secondly, a decentralized management structure stimulates the growth of competitiveness in the organization, creates the challenging atmosphere. Thirdly, a manager expresses more independence and can see his contribution into problem solving in such a structure, which influences the results of the company's overall performance positively [1-4].

It is worth noting that Adaptation of an enterprise to new social-economic circumstances depends significantly on the efficiency of solving the task of forming the target integrated enterprise management structure function formation in correspondence with the realized business-processes [5-7].

▀ **1. The main approaches to the development of enterprise management structure and the optimal organizational structure design principles**

There are two typical approaches to an enterprise management structure formation. The first one implies building the management structure regarding the enterprise's inner formation, division of labor and management rationalization. The second one originates from proceeds from the necessity of constant management structure adjustment to the outer environment conditions.

The first approach has become the basis for formal (hierarchal) management structures, based on the following statements:

- division of labor on the basis of functional differentiation;
- strict power hierarchy;

- a system of rules, defining each enterprise member's rights and duties;
- a system of procedures, defining operation procedure for all situations you can face in the organization functioning process;
- ignoring personal behavior in relationship between the organization's employees;
- employee choice and promotion on the basis of their qualification.

Hierarchal type organizational structures contain:

- line-functional structure, based on a line management vertical and managerial labor differentiation in regard to the organization's functional subsystems;
- line-headquarters structure with a group of specialists, the so-called headquarters or operational analysis cell, being created to help the manager. Its goals include collecting and analysis of information about the outer and the inner environment, performing control, preparing solution projects, current information sharing and consulting the manager;
- divisional structure motivating an enterprise's division into elements and blocks by types of goods and services, groups of consumers or geographic regions.

The organizational structures, stated above, are characterized as complicated (with big number of horizontal and vertical interconnections); high-formalized; with top downward communications and insignificant participation of lower personnel in decision making.

The second approach to building an organizational management structure has appeared in the second half of the XX century. Its main characteristic is the orientation to the organization's link with the outer environment and its changes. This approach is represented by the matrix, brigade and project management structures, significant for group and individual responsibility of every employee for the general result. When such an approach is used there's no necessity in deep labor differentiation by types of works and special relations, imposed not by structure, but by the solved problem character appear between management process. That's why you have to consider the following principles while building organic type management structures:

- orientation on problems and abilities;
- lowering hierarchy to the minimum; polycentrism and changing leaders depending on the problems being solved; temporary functions assignment to groups;
- high level of horizontal integration between personnel; the orientation of relationship culture on cooperation, the personnel's mutual information awareness, self-discipline, development and self-organization.

The main tendencies of organizational structures evolution are the following:

- decentralization, reducing the quantity of levels in the management apparatus. Big companies have created or are creating strategic profit centers, that have gained wide-ranging powers in performing independent production and commercial activities, with this aim. Such centers (departments) fully finance their activity, enter business partners' relations with any companies;
- organizational structures reorganization;
- operations diversification, creation of small companies with innovative functions, oriented on production and active promotion of new products and technologies in the markets, aiming for reaching firm positions in the markets, within big enterprises;
- waiving administrative bureaucratic managerial structures. Wide usage of efficient means and ways of motivation, including distribution of shares between employees, and creating companies, being collective property of their employees, in the course of management process;

- orientation on market environment and satisfying the requirements of and inquiries of clients (an important factor of continuous perfecting and building organizational structures);

- expansion of charitable, humanitarian activities of organizations. Companies can't function and evolve successfully being reserved, «buttoned-up» organizations, only interested in reaching their own inner goals.

At an enterprise creation, building the management structure and system organizational designing methods are used.

The main aim of organizational designing is providing high level of an enterprise's activity organized nature. In order to reach high level of organized nature of any activity it is essential for it to be designed, directed with necessary instructions, information and resources, performed by a rational technology for this data [8].

When a new organizational structure is designed the enterprise must tend to reach the following goals.

1. Determine the types of physical and intellectual labor to be performed.
2. Distribute duties according to positions in such a way that they would be performed successfully and responsibility for their performance could be laid on individuals or groups, establish functions and responsibility for their performance.
3. Provide employees of all levels with:
 - information and other means, necessary for more effective duties performance (including feedback regarding the quality of their work);
 - efficiency measures, coinciding with the organization's goals and objectives;
 - motivation for working with maximum performance.

Moreover, when you design an organizational structure, you have to consider the following factors:

- forming final activity objectives as an initial basis for organizational structures creation;
- consistent consideration of organizational structures;
- variant-typologic arrangement of organizational structures' fundamental properties;
- multifactorial evaluation of management system requirements from the management object;
- working out an organizational method of the management system performance.

System approach to designing an organizational structure is displayed in the following aspects:

- it's important to consider the maximum quantity of factors, influencing each management task;
- it is required to identify and interconnect a system of functions, rights and responsibility in the management vertical – from the top to the bottom production management link in connection with the set goals;
- it is required to explore and institutionalize all links and relations in the management horizontal, i.e. in relation to coordination of activity of different links and management organs while performing general running tasks and perspective interfunctional programs realization;
- it is necessary to provide a seamless combination of management vertical and horizontal, considering finding a correlation of management centralization and decentralization, ideal for the given circumstances.

All of this requires a profoundly elaborated step-by-step structures designing procedure, detail analysis and definition of a system of goals, circumspect organizational divisions and their coordination forms detaching.

In order to build an optimal management structure the following factors should be considered:

- stratification;
- formalization;
- centralization;
- organizational structure complication.

This being said, the new management structure has to be adaptive, possess minimum quantity of hierarchal steps and shortest ways of information transferring [9-12].

2. The algorithm of building dynamic network organizational structures within an object-functional management system

Realization of business-processes within an integrated management system may differ from the enterprise's approved standard. Under such circumstances DMs must interact following the designed algorithm, assuming taking rational managerial decisions in real time situation. The functioning of the algorithm in real time situation is performed using the system of DMs' queries to the enterprise's integrated database.

Step 1. Arising of the situation, requiring a managerial decision to be taken. Such situations can arise on all IMS management levels during the enterprise's standard business-processes realization.

Step 2. The DM acts according to Petri net within the enterprise's regulations framework. For every group of problems, requiring managerial decisions to be taken, regulated Petri nets for DMs interactions are designed. Using these regulations allows to take rational managerial decisions in real time situation, excluding conflict situations.

Step 3. Checking the current business-process' compliance with the regulations within the IMS framework. The business-process' deviation from the regulations is recorded in the integrated database, allowing DMs $\{P^i\}$ to see the deviations occurred.

Step 4. The transition of managerial actions one level higher along the management hierarchy.

Step 5. Finding reasons of deviations from the regulations using the Ishikawa diagram on the level of DMs $\{P^n\}$ (fig. 2.1). Dynamic structures building in the IMS circumstances methodology efficiency evaluation criteria are interlinked and they represent reason-and-consequence strategy links: from the end financial results to the resources, inevitable for their reaching. That's why in order to provide rational management within IMS the system of feedback, based on aims and success factors interaction as the "one to many" correlation, has been created.

Step 6. Comparing actual time for the deviation reasons' detection with the enterprise's regulations. If $t < t_{\text{standard}}$ then transition to step 9 is carried out, if this condition is not met, transition is carried out to step 7.

Step 7. Transition to the next level of the management hierarchy.

Step 8. Comparing the management level with the end quantity of management levels on the enterprise. If after the cycle running from step 5 to step 8 the top management level has been reached, the transition to step 9 is carried out, if not, the transition to step 5 is carried out.

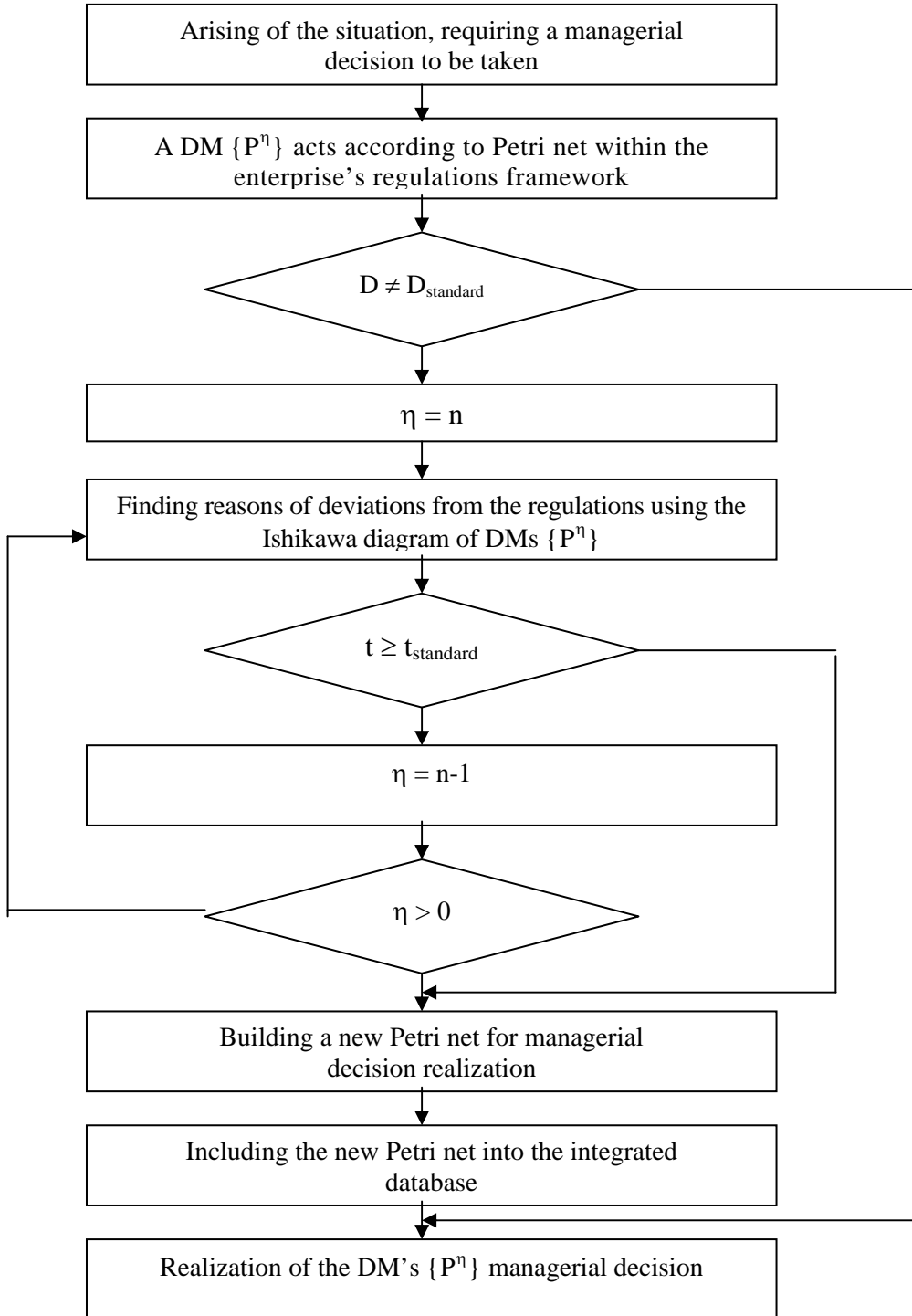

Figure 1. The algorithm of building a dynamic management structure within the IMS framework by business-processes

Step 9. Building a new Petri net for a managerial decision realization. Realization of this unit is performed by the DM of that management level, where the business-process

deviations from standard were detected. A Petri net can only be built by DMs, having powers in accordance with their functional duties.

Step 10. Adding the new Petri net to the enterprise’s integrated database. Realization of this step is performed within the enterprise’s regulations.

Step 11. Realization of the managerial decision on the DM $\{P^n\}$ level.

The method of building dynamic network management systems in the circumstances of an IMS allows to read information about the correlations between DMs, management objects, management functions from the integrated database. That’s why any deviations from the business-processes’ normal operation are fixed in the integrated database. A DM $\{P^n\}$ finds the reasons that had led to the non-standard situation using the Ishikawa diagram after the deviation appearance and then follows in accordance with the authorities given to him, considering the enterprise’s designed time regulations (fig. 2).

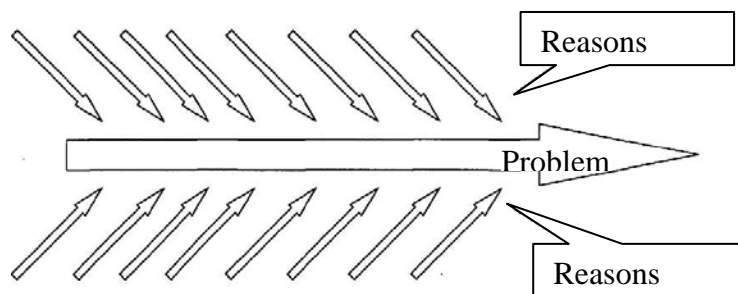

Figure 2. Ishikawa diagram of reason-consequence links in an IMS

3. Target dynamic organizational enterprise structure development function build-up process algorithmization

As the integrated enterprise management system development is characterized with a set of efficiency factors $y_i, i = \overline{1, I}$, which are reached in a specific sequence with various execution length $y_i(t)$, there should be the main condition, characterizing the target function of an integrated management system development by the enterprise:

$$Q(t) = \{y_1(t), \dots, y_i(t), \dots, y_I(t)\}. \tag{1}$$

Its forecasting should be carried out using the retrospective information. Multiple approaches are used in order to fold specific factors into generalized ones.

Firstly, priori folding is used, which allows to fold separate factors into a united one on the basis of the information you have. It’s important to find out the possible factor folding structures using this approach. Additive folding is used, which should satisfy the following conditions.

1. The $Q(t)$ function should be invariant to shear transformation

$$y'_i(t) = y_i(t) + C_1, \tag{2}$$

where C_1 is any constant.

This means that the following condition is met:

$$F\{y_1(t), \dots, y_i(t), \dots, y_I(t)\} = Q\{y'_1(t), \dots, y'_i(t), \dots, y'_I(t)\}.$$

2. The $F\{y_1(t), \dots, y_i(t), \dots, y_I(t)\}$ function must be invariant to changing the scale of any factor

$$y''_i(t) = I_1 y_i(t), \tag{3}$$

where I_1 is any positive number.

This means, that the following condition must be met

$$F\{y_1(t), \dots, y_i(t), \dots, y_l(t)\} = F\{y''_1(t), \dots, y''_i(t), \dots, y''_l(t)\}.$$

3. The $F\{y_1(t), \dots, y_i(t), \dots, y_l(t)\}$ function must be invariant to towards transformation

$$\widehat{y}_1(t) = I_1 y_1(t) + C_1. \tag{4}$$

The following folding meets the stated demands (5.2)-(5.4)

$$F\{y_1(t), \dots, y_i(t), \dots, y_l(t)\} = \sum_{i=1}^l \alpha_1 \frac{y_1(t) - y_1^{\min}}{y_1^{\max} - y_1^{\min}} = \sum_{i=1}^m \alpha_1 y_1(t), \tag{5}$$

where α_1 are scale coefficients, $0 \leq \alpha_1 \leq 1$, $\sum_{i=1}^l \alpha_1 = 1$;

y_1^{\min} , y_1^{\max} are the assumed minimum and maximum values of the forecast $y_1(t)$ function correspondingly.

A posteriori folding is performed in situations, when the information you have is enough for precise generated factor statement.

In this case there's a possibility in active information accumulation during the forecasting process. You can often manage to perform accumulation after carrying out a small number of experiments.

Experiments lay in checking the conjecture of some hypothesis about an enterprise's behavior as an economic system, which, after being performed, lead to partial or full elimination of the uncertainty, caused by determining the main restructuration program condition – the choice of a generalized factor and its parts. Such an approach is axiomatic.

The axiomatic approach is the most applicable from the point of efficiency among the considered approaches. If the axioms are used wisely, it is possible to reduce and sometimes even fully eliminate uncertainty in choosing the generalized factor. However, application of axiomatic methods is associated with significant problems. Firstly, the existing axiom systems are not always easily verifiable in specific tasks. Secondly, building axiom systems is impeded by the fact that they must be not complicated on one hand and informative enough to eliminate the possible uncertainties, on the other.

It is also possible to use adaptive approach, when each of the experiments carried out is not as informative as when the axiomatic approach is used and in order to eliminate uncertainties in choosing the generalized factor you have to carry out a significantly bigger number of such experiments. When such an approach is used each next experiment is carried out with regard to the result of the previous and factors folding represents an axiomatic target.

In order to build an adaptive algorithm of forecasting using a generalized factor it is suggested to unite forecasting and α_1 scale coefficients setting in one cycle of the generalized $Q(t)$ function (5.5) using expert information [11-17].

In order to perform forecasting in the specific $[n+1]$ moment of time using the known $y[1], y[2], \dots, y[n]$ time series the

$$y[n+1] = a_0 y[0] + a_1 y[1] + \dots + a_n y[n] + \varepsilon_{n+1}. \tag{6}$$

line model is accepted.

In order to determine the unknown a_j coefficients in the (5.6) equation we'll use the least squares method. We'll define the $y[n+1]$ value with the help of a line combination and the $z_i[n+1], \dots, z[n+1]$ functions, which take the $z_j[n+1] = y[n-1]$, $j = 0, 1, 2, \dots$ values. These functions are independent variables. All the data, subject to processing, is collected into table 3.1.

We'll use the statistical criteria to choose those, which are enough while building the

$$y[n]=a_0z_1[n]+a_1z_2[n]+...+a_{k-1}z_k[n], k < n. \tag{7}$$

line model, from the full array of independent variables, given in the table.

In order to set scale coefficients it is suggested to the expert to set the assumed border level of each $y_i(t)$ factor mentally at the y_i^{border} forecasting stage. In this case it is considered, that the factor's scale coefficient in the $Q(t)$ generalized function and the y_i^{border} scale coefficient coincide on the forecasting stage.

Table 1 – Values of parameters and the corresponding functions

Stage number	Parameters value	Independent variables					
		$z_1[n]$	$z_2[n]$	$z_3[n]$.	$z_{n-1}[n]$	$z_n[n]$
0	$y[0]$	-	-	-	.	-	-
1	$y[1]$		-	-	.	-	-
.
n-2	$y[n-2]$	$y[n-3]$	$y[n-4]$	$y[n-5]$.	-	-
n-1	$y[n-1]$	$y[n-2]$	$y[n-3]$	$y[n-4]$.	$y[0]$	-
n	$y[n]$	$y[n-1]$	$y[n-2]$	$y[n-3]$.	$y[1]$	$y[0]$

The $y_1[n+1]$ line forecasting model is built for every factor. The α_1 coefficients are set and the forecast generalized

$$F[n + 1] = \sum_{i=1}^I \alpha_1 \widehat{y}_1[n + 1]. \tag{8}$$

factor value is determined on the basis of priori information.

Simultaneously the following value is counted

$$F^{border}[n+1]= \sum_{i=1}^I \alpha_1 \widehat{y}_1^{border}. \tag{9}$$

After the computing, stated above, the information is analyzed by an expert. If the expert is not worried about the quick approaching to border values regarding the generalized factor and each individual factor, the generalized factor reflects individual factors' tendencies, then the α_1 coefficients are used for the next step of forecasting. In case of contradictions between the evaluation of the generalized factor changes and some (S^{th}) factor the adaptive adjustment of the α_1 coefficients for the $(n+1)^{th}$ step of forecasting is carried out.

The evaluation of contradictions, stated by the expert, is formalized the following way:

$$A_s^n = 1; A_i^n = -1; (i = \overline{1, I}, i \neq s),$$

The coefficients adjustment algorithm looks like this

$$\alpha_s^{n+1} = \frac{\alpha_1^n + \varepsilon^{n+1}}{1 + \varepsilon^{n+1}}; a_1^{n+1} = \frac{\alpha_1^n}{1 + \varepsilon^{n+1}} (i = \overline{1, I}, i \neq s)$$

$$\varepsilon^{n+1} = \varepsilon^n \exp[a \text{ sign} A_s^n - A_s^{n-1}],$$

where α is some positive constant.

The structural scheme of the target enterprise management system development function forming algorithm, providing record of quantitative forecasting evaluations of the realized business-processes on the basis of expert information is presented on figure 3.

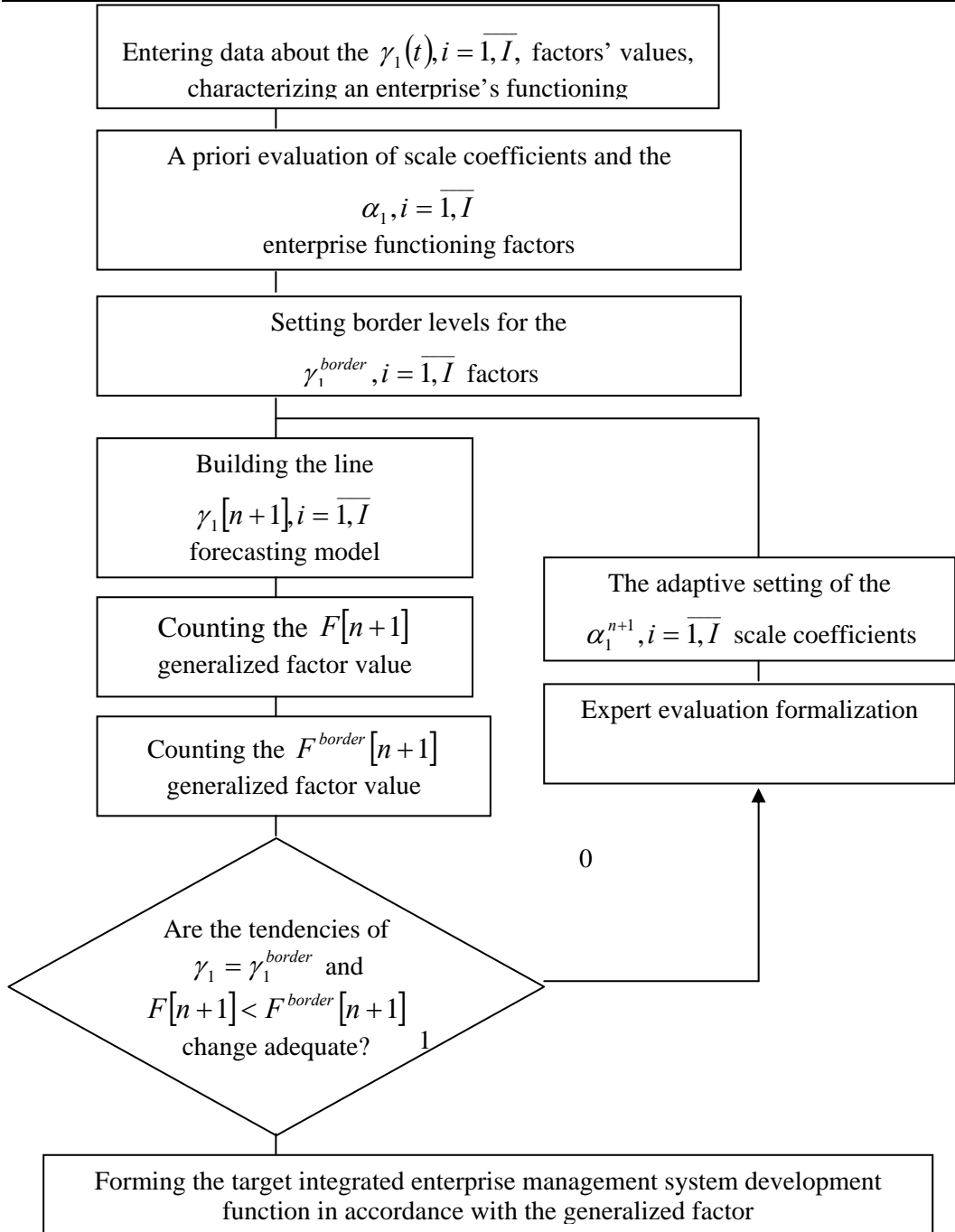

Figure 3. Structural scheme of the target integrated enterprise management system development function forming algorithm

Conclusion

Therefore, as a result of this study the algorithm of building a dynamic structure in an integrated enterprise business-processes management, realized in real-time mode and

allowing to make rational managerial decisions, excluding conflict situations, has been formed; the algorithm of generation of a target function of an integrated enterprise management system development on the basis of expert information forecasting and analysis procedures, has been developed.

References

- [1] SPERKA M. 2015. *Special aspects and principles of identification of objects with inhomogeneous characteristics*. In: Information Technology Applications, ISSN 1338-6468, no 1, p. 3-12.
- [2] SCHINDLER F. 2015. *Algorithmization of decision-making in management of objects with inhomogeneous characteristics*. In: Information Technology Applications, ISSN 1338-6468, no 1, p. 13-22
- [3] LVOVICH I. 2015. *Structurization of an expert and virtual resource of the corporate intellectual capital in the environment of adoption of administrative decisions*. In: Information Technology Applications, ISSN 1338-6468, no 1, p. 23-32.
- [4] RUZICKY E. 2015. *Formalization of userinteraction with virtual expert resource of knowledge type via ontological modelling*. In: Information Technology Applications, ISSN 1338-6468, no 1, p. 23-32.
- [5] PREOBRAZHENSKY Y. P. 2010. *The wording and classification of problems of optimal control production facilities*. In: Bulletin of Voronezh State Technical University, ISSN 1994-1730, vol. 6, no 5, p. 99-102.
- [6] CHOPOROV O. N. 2008. *On significance Methods of analysis parameters in the classification and predictive modeling*. In: Bulletin of Voronezh State Technical University, ISSN 1994-1730, vol. 4, no 9, p. 92-94.
- [7] MOSKALCHUK Y. I. 2013. *Problemy optimization of innovation processes in organizations*. In: Simulation, optimization and information technology, no 2, p. 10.
- [8] GUSKOVA L. B. 2012. *On the construction of the automated work place manager*. In: Successes of modern science, no 6, p. 106.
- [9] RODIONOVA K. Y. 2012. *Globalization of the world economy: the nature and contradictions*, In: Herald of the Voronezh Institute of High Technologies, no 9, p. 185-186.
- [10] SHISKINA Y. M. 2011. *Public administration*. In: Recent studies of social problems, no 2, p. 241-242.
- [11] PENKOV P. V. 2012. *Expert methods to improve control systems*. In: Herald of the Voronezh Institute of High Technologies, no 9, p. 108-110.
- [12] RYAZHSKIY A. M. 2008. *Construction of stochastic models of business processes optimization*, In: Herald of the Voronezh Institute of High Technologies, no 3, p. 79-81.
- [13] KOROLKOV R. V. 2013. *Controlling the trade organization*. In: Herald of the Voronezh Institute of High Technologies, no 10, p. 287-290.
- [14] LISITSKY D. S. 2008. *Building a simulation model of socio-economic system* In: Herald of the Voronezh Institute of High Technologies, no 3, 135-136.
- [15] SAMOYLOVA U. A. 2014. *Some characteristics of the enterprise management*, In: Herald of the Voronezh Institute of High Technologies, no 12, p. 176-179.

- [16] KOROLKOV R. V. 2013. *On the financial management of the organization*, In: Herald of the Voronezh Institute of High Technologies, no 11, p. 144-147.
- [17] KRAVTSOV D. O. 2008. *Methods of optimal control of socio-economic system based on the adaptation*. In: Herald of the Voronezh Institute of High Technologies, no 3, p. 133-134.

Prof. RNDr. Frank Schindler, Ph.D.

Pan-European University, Bratislava, Slovakia
frank.schindler@paneurouni.com

Prof. Vera Kostrova, D. Sc.

Voronezh Institute of High Technologies



Expert-optimization modeling of control actions choice and allocation of functions in dynamic organizational structures

Martin Šperka, Juraj Štefanovič, Igor Lvovich

Abstract:

A lot of modern enterprises have a network organizational structure. Along with the rapid expansion of external networks of cooperation with contractors, the in-company network organization is being transformed into a new, perspective means of a company dynamization. Compliance of the dynamic organizational structure with the targets of an enterprise functioning is determined by the degree of the control actions influence. To select the optimal control actions providing development of the dynamic organizational structure of an integrated enterprise management system, the adaptive choice algorithm diagram based on the results of the enterprise functioning indicators monitoring and expert assessments, is dIn order to select the reasonable variant of distribution of functions between levels and elements, the multi-alternative expert optimization model of an enterprise dynamic organizational structure improvement, based on the adaptive procedures is developed. By the example of a real enterprise, the example of building of the dynamic structure of business process management in an integrated management system (IMS) is considered. An approach to the development of an entity-relationship model of the decision maker (DM) organizational interaction system within the selected business process with the use of temporary databases, which provide support to an enterprise procedure, rules and regulations, as well as efficient information processing in real-time mode.

Key words:

Expert and optimization modelling, dynamic organizational structure, integrated management system, business process modelling, expert methods, adaptive approach.

ACM Computing Classification System:

Business process management, Business process modeling, Business process management systems, Business process monitoring, Cross-organizational business processes, Business intelligence

► Introduction

Organizational structure of a modern enterprise determines effectiveness of its activity and achievements of the determined business objectives.

Currently a new ideal organizational type, called network organization, is characterized by a network structure of freely interconnected equal and independent participants. The main configuration of network organization can be determined as a self-organizing political structure, forming with an orientation to specific goals and objectives and changes with every new problem situation uprising without disturbing the established managing relations balance. The basis of such a structure is constant, all-system communicational, reflexive interactions [1, 2].

New organizational-managerial forms are characterized with the following specialties:

- a «flat» hierarchy with clear power legitimation;
- responsibility decentralization with group forms of labour orientation;
- vertically and horizontally directed organizational connections and communication lines;
- cooperation coordination with the help of strict rules, goal setting and exact result evaluation.

Along with rapid outer contractor cooperation networks expansion, the intracorporate network organization becomes a new, perspective means of an enterprise dynamization and the practical organizational-managerial forms dynamization strategies can be divided into the following types.

Dynamization by introducing market mechanisms. Hierarchical management by means of power and rank is replaced at the enterprise by marketing powers on the basis of profit centres, participation in profits and other financial incentives. As a result of "inner markets" creation the money partly takes the function of the means of power coordination in a traditional organizational pyramid upon itself.

Dynamization on the individual behaviour level. In this case an effort is made to overcome the disadvantages of traditional forms by programme initiatives of inner enterprise spirit raising, aimed for individual behaviour dynamization.

Dynamization with the help of innovative combinations of different managerial strategies. In this case an effort is made to interlink the advantages of market logic with hierarchical control, minimizing the disadvantages of the latest and orientating on interorganizational cooperation forms, such as alliances, strategic networks and virtual enterprises. This strategy is based on new managerial logic – management using expert knowledge, and ultimately it means developing the intercompany network organization on the basis of trust and cooperation capability.

Correspondence of a dynamic organizational structure to the enterprise functioning goals is determined by the rate of managerial actions' influence. Simultaneously with the set of actions determining you have to determine their realization rate [3, 4].

1. Modelling of the process of choosing managerial actions, providing development of dynamic organizational structure of integrated enterprise management system development

It is helpful to grade the set of managerial actions in correspondence with the result of informational monitoring of enterprise activity factors for the current moment using the priority ranging method and choose the most significant ones, which will build the basis for building an assembly of managerial actions measures for a dynamic organizational integrated enterprise management system structure development.

Realization of these measures in modern conditions should be flexible and consider the possibilities of quick change of managerial actions priorities. An adaptive scheme of choosing actions with forecasting on the basis of informational monitoring results is suggested in order to provide the stated demand.

The following information sources for flexible choice of managerial actions set are used in the adaptive scheme:

1) forecasting expert evaluations of enterprise management about the efficiency of the j^{th} ($j = \overline{1, n}$) managerial impact on the i^{th} factor, characterizing the organizational structure development

$$B_{ij} = \begin{cases} 1, & \text{if the expert is satisfied with the effect} \\ -1 & \text{if not} \end{cases} \quad (1.1)$$

2) the data of informational monitoring of the i^{th} factor changes at the j^{th} impact;
 $\nabla y_{ij} > 0$ – change in the desired direction;
 $\nabla y_{ij} < 0$ – otherwise;

3) forecast evaluation models

$$\pi = p[y_{ij}^M(t_k) \leq y_i^D], \quad (1.3)$$

where π is the value of probabilistic forecast evaluation;

p is the probability value;

y_{ij}^M is the i^{th} factor, calculated using the mathematic model for the t_k moment of time;

y_i^D is the value of the i^{th} factor, desired by the expert.

If forming of (1.1), (1.3) evaluation doesn't require additional expert evaluation and monitoring results processing, it's necessary to form a forecast model of the time sequence for the y_i factor of the following type

$$y_i(t) = \varphi(a_0, a_1, a_2, t),$$

where $\varphi(\bullet)$ is the functional dependency from t , expressed analytically; a_0, a_1, a_2 are the φ function parameters.

The existence of an array of possible random φ function realizations with the industry sector's financial-economic state factors irregularity is considered as the result of the $\tilde{a}_0, \tilde{a}_1, \tilde{a}_2$ parameters' stochastic nature. In this case a random process is expressed by the following model:

$$\tilde{\varphi}(t) = \varphi(\tilde{a}_0, \tilde{a}_1, \tilde{a}_2, t),$$

and computing of numeric characteristics, such as: the m [$\varphi(t)$] mathematical expectation and the $D[\tilde{\varphi}(t)]$ dispersion, necessary to get the evaluation, is performed on the basis of

approximate mathematical statistics formulae using the $\tilde{a}_0, \tilde{a}_1, \tilde{a}_2$ parameters' numeric characteristics.

In the circumstances of the starting economic growth, related to realization of measures of influence on the organizational structure the

$$\varphi(t) = a_0 + a_1 t + a_2 t^2 \tag{1.4}$$

quadratic model seems the most acceptable

The (1.4) approximation has the biggest margin of error in comparison to the line exponential and logarithmic functions. It is helpful to determine the (1.4) model's coefficients on the basis of the exponential smoothing method, as it allows to consider the values of $y_i(t)$ monitoring, close to the choice at the moment of four managerial actions' priorities with bigger significance.

The following peculiarities of random process disposal using the (1.4) model are stated as a result of statistic data of an enterprise financial state factors.

1. The a_0 parameter depends on the state of the economic sector under the influence of influence measures and on the stage of reanimation and transition to stable development is a determined value.

2. The relative mean square deviation for the a_1 linear factor is significantly smaller than the corresponding value of the a_2 non-linear factor in connection with different tendencies of financial state dynamics for specific links of the economic sector's organizational structure:

$$\frac{\sigma(\tilde{a}_1)}{m(\tilde{a}_1)} \ll \frac{\sigma(\tilde{a}_2)}{m(\tilde{a}_2)},$$

where $m(\bullet)$ is the mean-square deviation designation.

That's why you should use the

$$a_1 = m(a_1).$$

parameter value during calculations.

3. Realization of the a_2 random value that depends on changing a big quantity of random factors, influencing the enterprise functioning process, showing no obvious domination, conforms the normal probability law

$$f(\tilde{a}_2) = \frac{1}{\sqrt{2\pi}\sigma(\tilde{a}_2)} \exp\left\{-\frac{a_2 - m(\tilde{a}_2)}{2\sigma(\tilde{a}_2)}\right\},$$

where $f(\bullet)$ is the random value frequency curve designation.

In this case the $p(0)$ function's numeric characteristics are determine the following way:

$$m[\tilde{\varphi}(t)] = a_0 + m(\tilde{a}_1)t + m(\tilde{a}_2)t^2$$

$$D[\tilde{\varphi}(t)] = D(\tilde{a}_1)t^2 + D(\tilde{a}_2)t^4$$

As the \tilde{F}_{ij} distribution tends to normal for the set period of managerial decisions taking, the (6.3) evaluation is calculated the following way

$$\pi = 0.5 + \Phi\left(\frac{y_i^* - m[\tilde{\varphi}(t)]}{\sigma[\tilde{\varphi}(t)]}\right),$$

where $\varphi(\bullet)$ is the normalized Laplace's function,

y_i^* is the value of the i^{th} economic sector state factor, desired from the point of crisis state escaping stage.

Rational choice of influences using the (1.1)-(1.3) array of evaluations is performed during multiple stages:

1. Transition from the ordinal evaluations scale of measures of influence priorities in correspondence with the results of monitoring for the set period to probabilistic evaluations:

$$p_j^1 = 1 - \frac{Q_j}{\sum_{j=1}^n Q_j},$$

where Q_j is the ordinal evaluation of the j^{th} managerial action;

n is the quantity of influence measures;

$Q_{j_1} > Q_{j_2}$, if the significance of the j_2 influence is bigger than that of the j_1 influence;

P_j^1 is the initial probabilistic evaluation.

$$\sum_{j=1}^n p_j^1 = 1.$$

2. The choice of an influence measure for the latest ($k = 1, 2, \dots$) period of the y_i factor change in the desired direction.

That's the goal of using the following logical rule. For the first ($k = 1$) period we use the managerial action, that has the smallest Q_j degree, acquired in accordance with the results of the y_i factor monitoring.

For the following ($k > 1$) periods we perform the comparison of the $p_j^k, j = \overline{1, n}$ probabilistic evaluation with a random ξ number, well-distributed on the $[0, 1]$ interval. If $0 < \xi > p_j^k$, then we carry on managing using the previous influence, otherwise we proceed to the next one and so on.

3. Correction of $p_j^k, j = \overline{1, n}$ probabilities values for new management periods.

The necessity of p_j probabilities values correction for the k^{th} period is determined after the π^k evaluations. If $\pi^k < 0.8\pi^{k-1}$, then the correction is necessary.

The p_j probabilities values correction using the (1.1), (1.2) evaluations is carried out by the following algorithm:

$$p_j^k = p_j^{k-1} l^{-1/k} * \text{Sign} [B_{ij}^{k-1} B_{ij}^k]$$

$$p_v^k = \frac{P_v^{k-1} (1 - P_v^k)}{1 - P_j^{k-1}}, v = \overline{1, n}, v \neq j,$$

$$\text{if } \text{Sign} B_{ij}^{k-1} = \text{Sign} B_{ij}^k = -1$$

$$\text{or } p_j^k = p_j^{k-1} l^{-1/k} * \text{Sign} [\nabla_{ij}^{k-1} \nabla_{ij}^k]$$

$$\text{if } \text{Sign} \nabla y_{ij}^{k-1} = \text{Sign} \nabla y_{ij}^k = -1;$$

$$p_j^k = \frac{p_j^{k-1} + \varepsilon^k}{1 + \varepsilon^k}, p_v^k = \frac{p_v^{k-1}}{1 + \varepsilon^k},$$

$$\varepsilon^k = \varepsilon^{k-1} l^{-1/k} * \text{Sign} [B_{ij}^{k-1} B_{ij}^k]$$

$$\text{or } \varepsilon_j^k = \varepsilon_j^{k-1} l^{-1/k * \text{Sign} [\nabla F_{ij}^{k-1} \nabla F_{ij}^k]}$$

$$\text{if } \text{Sign} \nabla F_{ij}^{k-1} = -1, \text{Sign} \nabla y^k = 1,$$

$$\text{where } \text{Sign} (z) = \begin{cases} 1, & \text{if } z > 0, \\ -1, & \text{if } z < 0. \end{cases}$$

$$p_j^k = 1, p_\gamma^k = 0, \gamma = \overline{1, n}, \gamma \neq j,$$

$$\text{if } \text{Sign} B_{ij}^{k-1} = \text{Sign} B_{ij}^k = \text{Sign} \nabla y_{ij}^{k-1} =$$

$$\text{Sign} \nabla y_{ij}^{k-1} = 1;$$

$$p_j^k = p_j^{k-1}, p_\nu^k = p_\gamma^{k-1}$$

$$\text{if } \text{Sign} B_{ij}^{k-1} = 1, \text{Sign} B_{ij}^k = -1$$

$$\text{or } \text{Sign} \nabla y_{ij}^{k-1} = 1, \text{Sign} \nabla y_{ij}^{k-1} = -1$$

2. Expert-optimization modelling of the process of functions distribution in dynamic organizational structures of an integrated enterprise management system

Development of an enterprise's dynamic organizational structure is carried out simultaneously with perfecting the integrated management structure. This process is related to adaptive distribution of management functions between the top – administrative – and the bottom – production – management levels. The efficiency of measures of influence on the development of a dynamic organizational structure is determined by justification of management functions' distribution [5-7].

The expert-optimization modelling is used to choose the rational variant of functions' distribution between management levels.

The economic segment's top management level is represented by $j = \overline{1, n}$ elements and performs $i = \overline{1, m}$ management functions in correspondence with the realized business-processes.

It is necessary to determine the significance of every i^{th} management function on the first stage for decision taking at the higher level. Such a possibility is presented by group expert evaluation of these functions using the priori ranging method. The value of a_i rates can be from 1 to m depending on function significance. Normalized values are introduced to increase the comfort of using such evaluations:

$$b_i = 1 - \frac{a_i}{\sum_{i=1}^m a_i}.$$

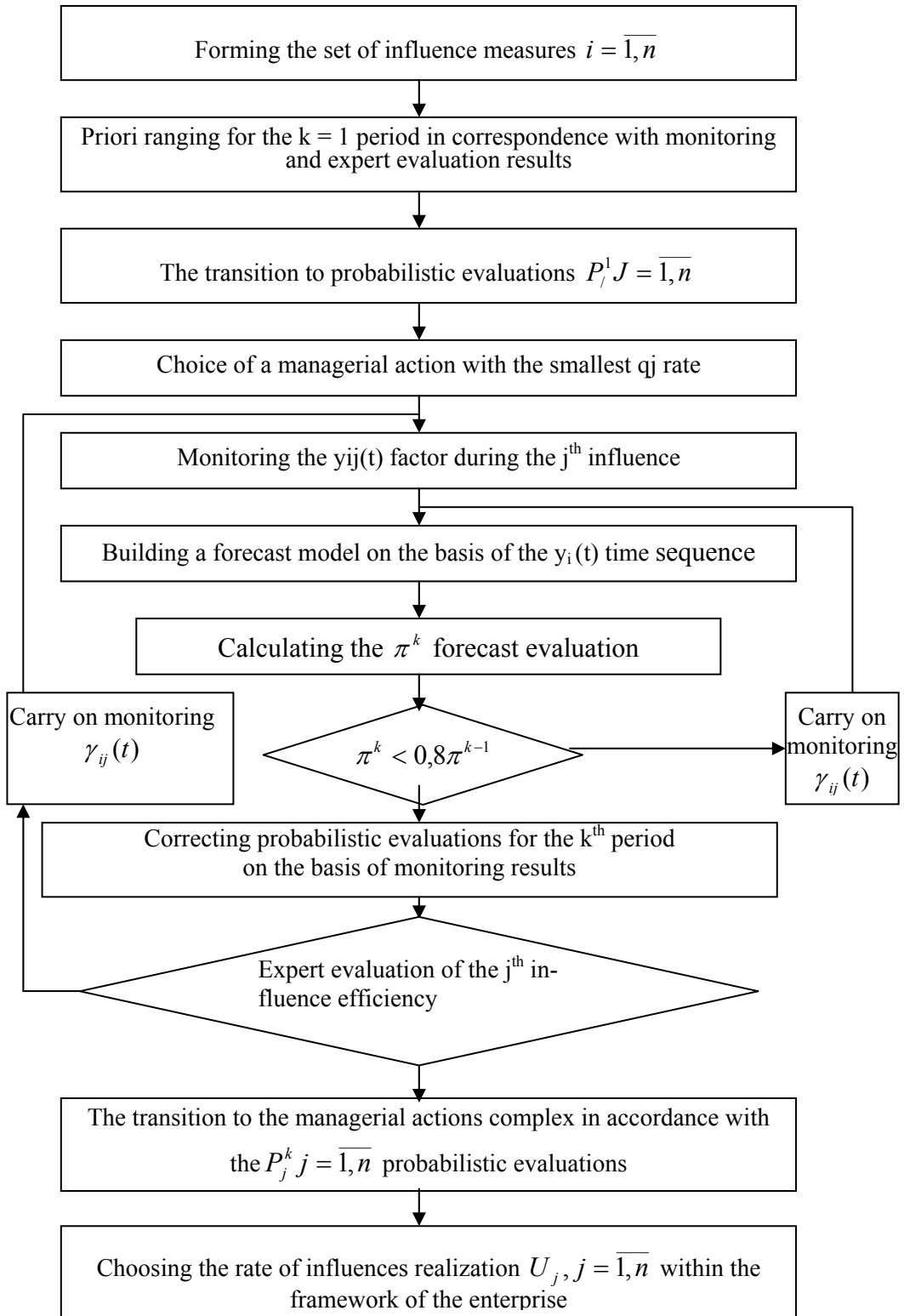

Figure 1. A structural scheme of adaptive choice of managerial decisions in accordance with the results of the enterprise's functioning factors monitoring and expert evaluations

The character of the $j = \overline{1, m}$ management functions performing by top level elements is determined by the following discrete value:

$$C_{ij} = \begin{cases} 1, & \text{if the } i^{\text{th}} \text{ function can be fully carried out by the } j^{\text{th}} \text{ element} \\ 0.5 & \text{if the } i^{\text{th}} \text{ function can be partly carried out by the } j^{\text{th}} \text{ element} \\ 0, & \text{otherwise} \end{cases} \quad (2.1)$$

$$j = \overline{1, n}, i = \overline{1, m}.$$

Alternative variables are introduced in order to analyse variants of functions distribution:

$$x_i = \begin{cases} 1, & \text{if the } i^{\text{th}} \text{ function can be transferred to the higher level} \\ 0, & \text{otherwise} \end{cases} \quad (2.2)$$

$$i = \overline{1, m}.$$

Optimization is carried out following the principle of maximum significance at management functions delegating to a higher level of the enterprise's dynamic organizational structure, which corresponds with the optimality criterion

$$\sum_{i=1}^m b_i x_i \rightarrow \max. \quad (2.3)$$

Limitations are connected with management functions performance labour intensity by the higher level elements.

Average labour intensity of performing the i^{th} management function by the j^{th} element for the specific calendar time period is designated as t_{ij} , the planned labour intensity of the j^{th} element management activity is T_j . In this case the limitations are presented in the following way:

$$\sum_{i=1}^m t_{ij} c_{ij} x_i \leq T_j, j = \overline{1, n}. \quad (2.4)$$

Considering (7.1)-(7.4) the optimization model looks the following way:

$$\begin{aligned} \sum_{i=1}^m b_i x_i &\rightarrow \max, \\ \sum_{i=1}^m t_{ij} c_{ij} x_i &\leq T_j, j = \overline{1, n}, \end{aligned} \quad (2.5)$$

$$x_i = \begin{cases} 1, \\ 0 \end{cases} \quad i = \overline{1, m}.$$

A random generation of accepted variants, answering the (2.4) limitations is carried out in order to solve the (2.5) optimization task. Each variant of $x_l, l = \overline{1, L}$ is a set of random x_i values:

$$X_l = (\tilde{x}_1, \dots, \tilde{x}_i, \dots, \tilde{x}_m),$$

$$\text{where } \tilde{x}_i = \begin{cases} 1, & \text{if } \tilde{\xi} \leq p_i \\ 0, & \text{otherwise,} \end{cases}$$

$\tilde{\xi}$ is a random number, well-distributed on the (0, 1) interval;

p_i is the set probability that the variable $x_i = 1$.

Building new variants, providing maximization of the target (2.3) function on the accepted (2.4) array, is carried out on the basis of genetic algorithms.

The array of $x_l, l = \overline{1, L}$ variants is represented by the $\Pi = (x_1, \dots, x_l, \dots, x_L)$ population, in which any two specimen of x_l, x_t on the basis of the acts of syngamy and meiosis. The algorithm of aggregation is determined firstly, by the way of choosing a $x_l, x_t \in \Pi$ parent pair, bearing the father's and the mother's gamete correspondingly (the system of breeding), and secondly, by the scheme of multiplication. The values of the target (2.3) function, which are interpreted as the $\mu(x_l)$ rate of adaptation for every x_l specimen, having the $E(x_l)$ genotype, are calculated in order to realize the stated.

The system of breeding, defining the choice of specimen for a parent pair is considered during aggregate tasks solving. In order to realize the breeding system, connected with genotype panmixis, all the specimen $(x_1, \dots, x_l, \dots, x_L)$ are divided into local populations $\Pi_g \neq 0, g = \overline{1, G}$ ($g \leq L$), in each of them the Hamming distances between any pairs of genotypes equal zero. As a $(x_l, x_t) \in \Pi$ parents pair any two $x_l \in \Pi_{g1}$ and $x_t \in \Pi_{g2}$ ($\Pi_{n1} = \Pi_{n2}$) specimen are chosen, where the local populations are chosen randomly following the probability distribution

$$P_g = L_g / L, g = \overline{1, G}, \tag{2.6}$$

where L_g is the size of the local Π_g population.

Other breeding systems are determined by Hemming distances between the $E(x_l)$ and $E(x_t)$ genotypes of the two $x_l, x_t \in \Pi$ specimens. If it doesn't exceed the set positive number d_0

$$d[E(x_l), E(x_t)] = \|E(x_l) + E(x_t)\| \leq d_0, \tag{2.7}$$

where $E(x_l) = (l_0(1), \dots, l_0(m), \dots, l_0(M), l_0(m))$ is the allel of the m^{th} locus of the 1^{st} specimen, $l_0(m) = Z_{ml} >$, then the specimens are considered close relatives and choosing a parent pair from the specimens, meeting the (2.7) condition, leads to the system of breeding called inbreeding. A diametrically opposite system to this one is outbreeding, when the choice of a parent pair is carried out on the assumption that

$$d[E(x_l), E(x_t)] > d_0.$$

Using the quantitative evaluation of the $\mu(x_l)$ rate of adaptation we can form the systems of assortative breeding. In case of positive assortative breeding during parent pair formation those specimens, that have close and high levels of adaptation rate are chosen. Specimens are chosen on the basis of the following probability distribution:

$$P_t = \frac{\mu(x_t)}{\sum_{i=1}^L \mu(x_i)}, t = \overline{1, L}. \tag{2.8}$$

In case of negative assortative breeding one of the specimens is randomly chosen following the (2.8) distribution and the second one is chosen on the basis of the following distribution:

$$P_t = [1/\mu(x_t)] \sum \left(\frac{1}{\mu(x_t)} \right), t = \overline{1, G}. \quad (2.9)$$

An isolated situation of positive assortative breeding is selective breeding, during which the specimens, that have the levels of adaptation, which are lower than the average adaptation rate of the μ_{ave} population are excluded from the Π population.

$$P_t = \left[\frac{1}{\mu(x_t)} \right] \sum_{i=1}^L \left(\frac{1}{\mu(x_i)} \right), t = \overline{1, G}.$$

Next, the random choice, following the (2.9) probability distribution, is used.

The basis for specimens breeding schemes and building new aggregated variants is gene recombination. Recombination leads to appearance of new combinations of parent genes, as the allele of any gene of the parent's homologous chromosome is fully propagated to the ancestor in accordance with the law of dominance. At this the parents' homologous chromosomes are compared by the contents of each gene. If the alleles in the m^{th} ($m = 1, M$) locus are the same in the father's and the mother's chromosomes [$l_0^{oc}(m) = l_0^M(m) = l_0(m)$], then the $l_0(m)$ allele is kept in the ancestor's m^{th} gene. Otherwise, [$l_0^{oc}(m) = l_0^M(m)$] there's a 50% probability that the allele or the $l_0^M(m)$ allele is brought into the m^{th} locus of the ancestor's gamete. This operation of random division of the parents' genes along the ancestors' gametes allows to form new aggregated variants. Mutual exchange of homologous chromosomes' sections (crossing-over) is also possible. During simple crossing-over homologous chromosomes-zygocites, before they split into child gametes of the ancestors, are torn apart in the random α spot into two M_1^M and M_2^{om} parts, containing genes from $(\alpha + 1)$ to M , and then they are provided with the corresponding sections of tangled genes or are restored in the initial state.

If the new variant's adaptation rate $\mu(x_{L+1}) > \mu^{max}(x_1)$, then this variant is included in the array of perspective variants and the variant with $\mu^{min}(x_1)$ is excluded from the array. Then this method of parent pairs choice is used. The process finishes after all possible parent pairs are handled.

In order to cut down the array of perspective variants of parent pairs a reproductive group is formed on the basis of selection schemes. Two basic schemes are the most widely spread.

In the first case all specimens are harmonized in the descending order of their adaptation factor value. The L_0 reproductive group number is set. Only L_0 of the harmonized specimens are included in the R reproductive group.

In the second case the average adaptation rate of all specimens is determined:

$$\mu^{ave} = \left(\frac{1}{L} \right) \sum_{l=1}^L \mu(x_l).$$

Only the specimens with the level of adaptation, which is higher or equals the average one, are included in the reproductive group:

$$R = \{x_i | \mu(x_i) \geq \mu^{ave}(x_i), i = \overline{1, G}\}.$$

The variants that have been included in the reproductive group are then subject to expert evaluation for the ultimate choice of the rational variant.

3. Building a dynamic enterprise business-processes management structure within an IMS

The mathematic model of interaction between DMS, management objects and business-processes is built using the Petri net apparatus. When building a Petri net positions

can be displayed as DMs as well as situation analysis state; and the transitions can display both managerial decisions and messages about some events. In order to reflect a complicated transition in the network an element is used, which considers an assembly of inner situations while taking managerial decisions about the transition from one DM to another. The contents of positions and transitions in Petri nets reflects the sequence of taken managerial decisions and functional connections between DMs rather fully (Fig. 2).

Building a management structure in the circumstances of an enterprise IMS is considered using the example of OJSC Vodmashoborudovanie plant (Voronezh), which specializes in producing equipment for drinking and sewage water treatment and fire-extinguishing equipment.

The work assumes setting channels of rational interaction between management objects and DMs to provide the process of functioning of technologic business-processes of the considered enterprise. Meeting these requirements assumes determining of the necessary input and output information for every integrated enterprise object to make managerial decisions. The organizational structure allows to determine a system of DMs' organizational interaction within the chosen business-process [9-13].

The result of building informational interlinks in the existing management structure is forming an information model of an enterprise with new functional DM relationships.

Determining new informational relationships between DMs changes document workflow for managerial decisions making within business-processes. Based on this consumption we can build a new informational enterprise model as a cube with one of its edges being represented by Petri nets, built for managerial decisions realization within technologic business-processes. That's why every DM in the circumstances of an IMS in the process of decision making acts within the framework of his personal functional duties in accordance with the Petri nets within the enterprise's regulations. The new informational interaction between DMs allows to reduce the time for managerial influences on functional business-processes realization functioning significantly (fig. 2).

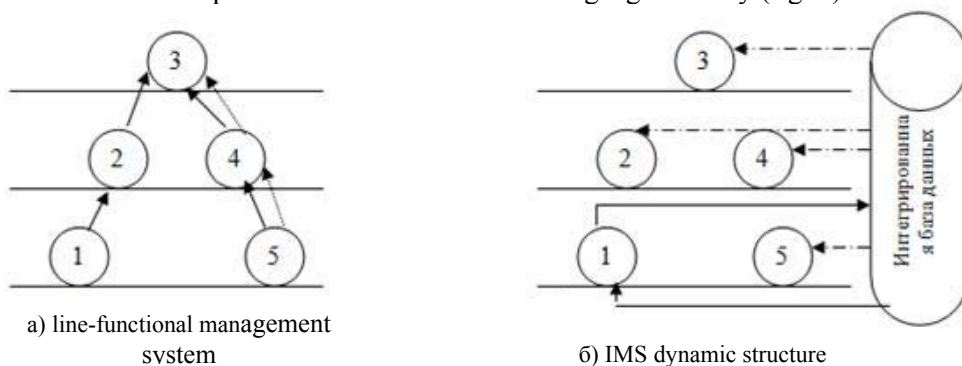

- ▶ - a DM's managerial action for making a decision
- - - - -▶ - managerial decision realization control
- · - · - ·▶ - a DM's query to the database, realizing the function of managerial decision realization control

Figure 2. The procedure of managerial action passing in a line-functional management system and a dynamic IMS structure

From the point of technical realization of an enterprise's managing information systems the corresponding instruments are used, which allow to realize the system's func-

tional abilities completely. The main requirement, applied to the information storage environment is correspondence of the information kept to specific time intervals, and presence of the "time" attributes of the data. Presence of such attributes of the data management system itself provides maximum efficiency while working with temporary data. The main function, laid on temporary databases, has been determined as automated and, in some cases, automatic adherence to the regulations of decision makers' (DMs') work, and performance discipline control. The principal scheme of using a temporary database in a system of supporting managerial decisions of the considered enterprise is presented on figure 3. [11, 14, 15].

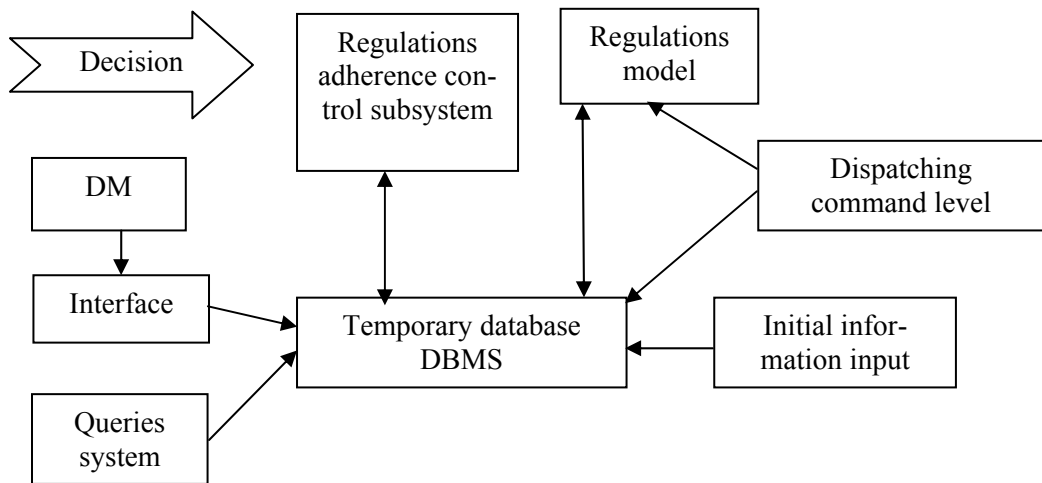

Figure 3. The scheme of using a temporary database for managerial decisions realization control

Temporary databases have been used in order to support the working capacity of the automated integrated management system. Every attribute has the time property: it possesses actual time, determining its value timeliness and the transaction time, which determines the time of information writing to the system. Time attributes have been set for such dynamic processes, as dispatching command subsystems, procurement subsystems, current technologic equipment maintenance subsystems and some others.

In order to provide effective information processing, distribution of transactions handling and methods of working with the database's time attributes, has been made. Queries are processed by the DBMS itself, while forming queries to the temporary database is carried out by the user himself. Regulations of the enterprise management system interaction is realized in the form of functions, the DMs should adhere to. These functions include time attributes as well. Controlling of the regulations adherence is carried out by the business-rules, set on the application server level. Supporting feedback is also carried out by means of the application server's functionality. Taking into consideration the deviation of the values from the set ones, one or another management business-function is carried out.

However, as a result of technologic business-processes' functioning deviations from the normal values, set at the enterprise, can occur. In such cases new Petri nets are built to provide conflict-free process of managerial decisions making in real-time mode. When a situation, requiring managerial decision to be taken by a DM, the person responsible for managerial decisions making for specific management objects will initially act in corre-

spondence with the Petri net, that has been designed and is kept in the integrated DB, containing information about correlations between DMs, management objects, management functions. That's why any deviations from the normal performance of business-processes are fixed in the integrated database. The DM {pn} finds the reasons that had led to the non-standard situation using the Ishikawa diagram, after the situation occurs [11, 16, 17].

Detecting reasons of business-processes' deviations from normal work on the level of DMs {pn} should be carried out strictly within the limits of time set by the enterprise's standard. In case if the given reason detection time limit is exceeded by DMs {pn}, this operation is transferred one level higher along the management hierarchy. This cycle of detecting the reasons that had led to deviations in the business-process flow, will repeat until the top management level is reached, where power delegation for this management function is not possible anymore.

After detecting the reasons a new Petri net is built by DMs {pn} to make a managerial decision, variants of network interactions are built for the "machine-tool repair" business-process participants in order to solve the resultant problem. It's important to point out that DMs can build new Petri nets only within their functional duties by management objects according to the built enterprise model. The new net is recorded to the integrated database for making a managerial decision at the current moment and to solve the similar problem if it happens again.

Production process has a specific time step and is determined by the enterprise's specific character. The period of time steps makes from a couple of minutes (for dispatching control) to multiple days.

We can pinpoint some time-consistent processes within this time step.

On the level of initial information, getting to the system at the specific time moment (it is determined as T4) we record the results of the technologic business-process that lasts in time since T1 till T2. The registered T3 time determines the final time of the technologic business-process end. Control of the personnel's actions' correctness and timeliness is performed till the T5 time. During the T6 time everything is ready for managerial decisions making on the basis of the recorded information, related to the technologic business-process since T1 till T2. The T6–T1 interval determines the minimum time step of the managing link reaction to correct the disturbing factor of the technologic business-process. The possible solution variants are determined by a set of attributes of the technologic process objects, that have the corresponding regulation range. T1, T2, T3, T4, T5, T6 time moments are the implicit attributes of the generalized enterprise informational model object.

Forming queries involving the T1, T2, T3, T4, T5, T6 time moments we get the information, allowing to:

- perform the technologic business-process control;
- determine the set of possible solutions to correct the technologic business-process;
- perform the choice of administrative business-solution to correct the disturbing factor of the technologic business-process.

In an object-functional enterprise model such a technology of administrative business-processes production allows to distribute the possible variants of business-processes within DMs.

In order to illustrate the possibility of getting a business-solution using a time data model we can use the example of an information query, allowing to get information about the state of the object for the T_i moment of time (fig. 4.).

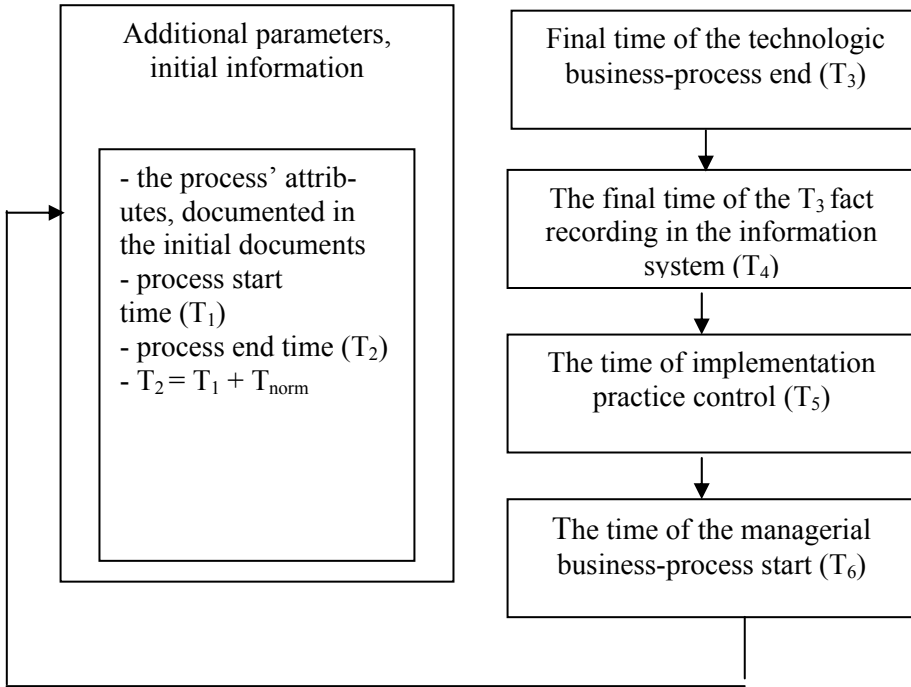

Figure 4. The generalized scheme of DMs interaction with the information system

A query is formed at first order predicate language:

$$\begin{aligned}
 OSD_Inst = & (\exists X1, X2, X3, X4, X5, X6, X7, X8, X9, X10, X11) \times \\
 & (\exists S1, S2, S3, S4) \\
 & (S1 \in OSD_Inst_Table) \wedge (S2 \in PSD_Table) \wedge (S3 \in OSDP_Table) \wedge \\
 & (S4 \in Val_Table) \wedge X1 = S1.ID_OSD \wedge X2 = S1.Inst_ID \wedge X3 = \\
 & S1.ID_OSDP \wedge X4 = S3.Display \wedge X5 = S3.Order1 \wedge X6 = \\
 & S3.Multivdenc e \wedge X7 = S2.Type \wedge X8 = S2.Name \wedge X9 = \\
 & S1.ID_Value \wedge X10 = S4.Value1 \wedge T_i \geq S1.DateFrom \wedge \\
 & T_i < S1.DataBefore \wedge X1 = C1 \wedge X2 = C2 \wedge X3 = S2.ID_OSDP \wedge \\
 & X4 = C3 \wedge X3 = C4 \wedge X5 = C5 \wedge X6 = C6 \wedge X7 = C7 \wedge X8 = \\
 & C8 \wedge X9 = S4.ID_Value \wedge X9 = C9 \wedge X10 = C10
 \end{aligned}
 \quad \left. \vphantom{\begin{aligned} OSD_Inst = \\ \dots \\ \dots \\ \dots \\ \dots \\ \dots \\ \dots \\ \dots \\ \dots \\ \dots \end{aligned}} \right\} (3.1)$$

where $X1, X2, \dots, X12$ are running terms;

$C1, C2, \dots, C10$ are constant terms (the broadcast conditions of the managed object values samples);

S is the array of the sequences of specimens of the object in the application environment (OAE).

The same query in SQL language will look the following way:

Select A.ID_OSD, A.Inst_ID, A.ID_OSDP, C.Display, C.Order1,
 C.Multivalence, B.Type, B.Name, A.ID_Value, D.Value1,
 A.DateFrom, A.DateBefore
From OSD_Inst_Table A, PSD_Table B, OSDP Table C (3)

Where (A.ID_OSD=C1) And (A.ID_PSD=C2) And
 (A.ID_OSDP=C3) And (C.Display=C4) And
 (C.Order1=C5) And (Multivalence=C6) And
 (A.ID_Value=C7) And (D.Value1=C8) And
 (DateFrom >= T_i) And (DateBefore < T_i),

where OSD_Inst_Table is the table, containing OAE specimens;

PSD_Table is the table, containing information about AE;

OSDP_Table is the table, containing OAE parameters;

ID_OSD is the OAE identifier;

Inst_ID is the OAE specimen identifier;

ID_OSDP is the OAE setting identifier;

Display is the parameter of an application environment object's parameter displaying (AEP);

Order 1 is the order of AEP displaying;

Multivalence is the determinant of the AEP's multivalence;

Type is the type of the application environment parameter;

Name is the name of the application environment parameter;

ID_Value is the OAE parameter value identifier;

Value 1 is the OAE parameter value;

DateFrom and DateBefore are the dates of the version start and the end of the OAE.

C1, C2, ..., C8 are the parameters of the AEP parameters search method;

T_i is the regulations time (i = 1...6).

Thus, a system of information queries is presented to support the system of managerial decisions making in an object-functional management model by mean technologic business-processes control and operational management [1, 2].

DMs in an IMS must interact with the information system following the developed algorithm, assuming rational managerial decisions making in real-time mode. Functioning of this algorithm in real-time mode is carried out using the system of DMs' queries to the integrated temporary database of the enterprise. A step-by-step description of the algorithm is presented on figure 5.

Step 1. Occurrence of a situation, requiring a managerial decision to be made. Such situations can happen on all management levels of the IMS during realization of the enterprise's standard business-processes.

Step 2. DMs are informed about the state of an object at the current moment of time by a background process of the temporary database.

Step 3. A DM $\{p^n\}$ acts in accordance with the regulations within the limits of his official duties. For every group of problems, requiring managerial decisions to be made, proceduralised Petri nets have been built for DMs' interactions. Using these regulations allows to accept the query to the temporary database about the state of the object at the current moment of time.

Step 4. If there are no alternatives, the analytic production information processing unit is turned on to determine the possible alternatives.

Step 5. Checking correspondence of the current business-process to the normal one within the framework of an IMS. Deviations of a business-process' parameters from the regulations are fixed in the temporary database, allowing DMs $\{p^n\}$ to see the deviations happening.

Step 6. Comparing the actual deviation reason detection time with the normal value stated in the enterprise's regulations. If $T \leq T_{reg.}$, then the transition to step 7 is carried out,

if this condition is not met, the transition is carried out to step 8.

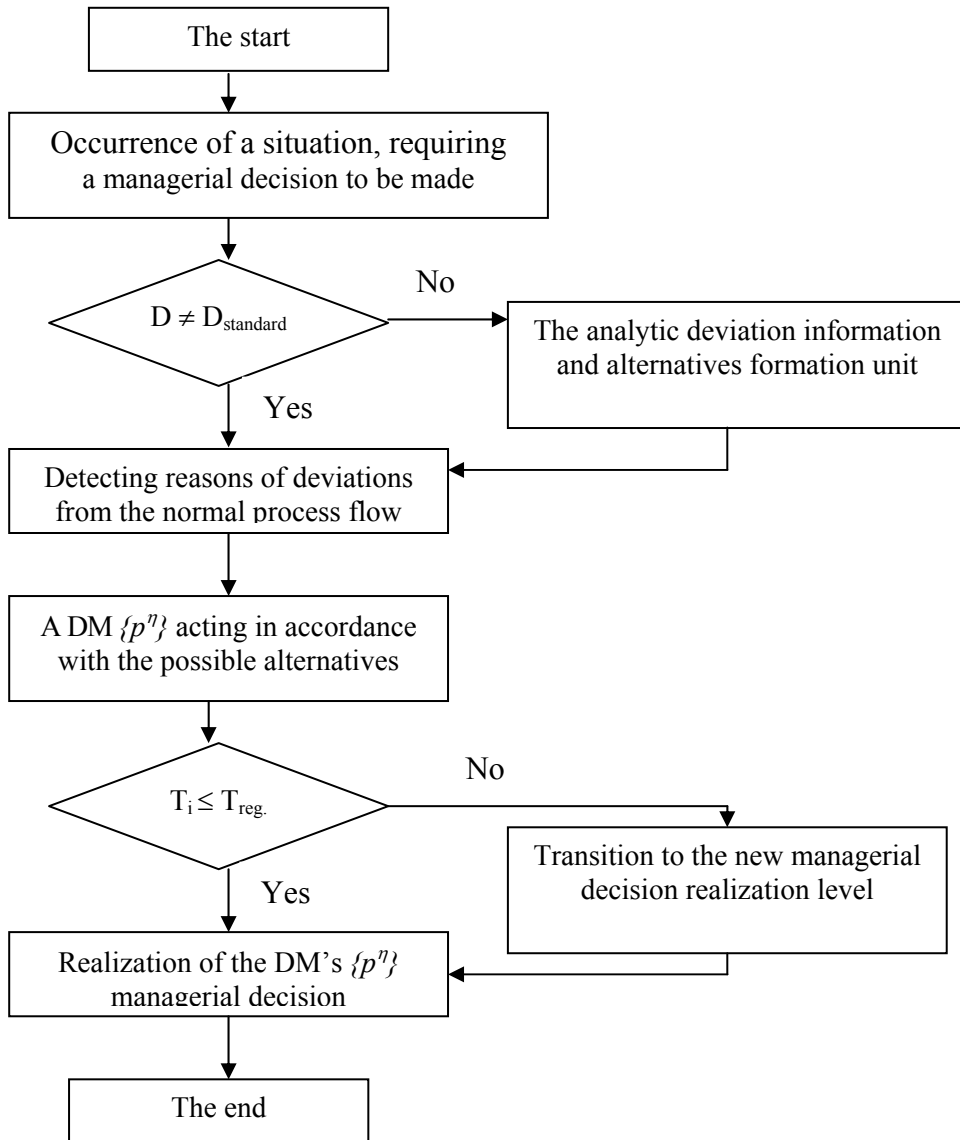

Figure 5. The algorithm of managerial decision making in the IMS circumstances

Step 7. Realization of the managerial decision and transferring the management object to the new state.

Step 8. Informing the higher management level about the managerial decision rejection and management transition to the administrative subsystem.

Conclusion

Therefore, as a result of this study the algorithmic scheme of choosing a set of managerial actions, based on the analysis of enterprise functioning factors evaluations, acquired on the basis of information monitoring results, has been suggested.

A multi-alternative expert-optimization a dynamic organizational enterprise structure perfecting model, characterized by the procedure of adaptive choice of the variant of distributing functions between management levels and elements, has been designed.

An approach to forming an information model of a system of organizational interactions between DMs within the framework of a chosen business-process using temporary databases, providing the enterprise functioning regulations and effective information processing in real-time mode support on the basis of information arrays structuring in an integrated database, determining the key information arrays and organizing the interaction between them, has been suggested.

References

- [1] ŠPERKA, M. 2015. Special aspects and principles of identification of objects with inhomogeneous characteristics. In *Information Technology Applications*. ISSN 1338-6468, 2015, vol. 4, no. 1, p. 3-12.
- [2] SCHINDLER, F. 2015. Algorithmization of decision-making in management of objects with inhomogeneous characteristics. In *Information Technology Applications*. ISSN 1338-6468, 2015, vol. 4, no. 1, p. 13-22.
- [3] LVOVICH, I. 2015. Structurization of an expert and virtual resource of the corporate intellectual capital in the environment of adoption of administrative decisions. In *Information Technology Applications*. ISSN 1338-6468, 2015, vol. 4, no. 1, p. 23-32.
- [4] RUŽICKÝ, E. 2015. Formalization of user interaction with virtual expert resource of knowledge type via ontological modelling. In *Information Technology Applications*. ISSN 1338-6468, 2015, vol. 4, no. 1, p. 23-32.
- [5] PREOBRAZHENSKY, Yu. P., PANEVIN, Yu. 2010. The wording and classification of problems of optimal control production facilities. In *Bulletin of Voronezh State Technical University*. ISSN 1729-6501, 2010, vol. 6, no. 5, p. 99-102.
- [6] CHOPOROV O. N., CHUPEEV, A. N., BREGEDA, S. Y. 2008. Significance methods of analysis parameters in the classification and predictive modeling In *Bulletin of Voronezh State Technical University*. ISSN 1729-6501, 2008, vol. 4, no. 9, p. 92-94.
- [7] MOSKALCHUK, Yu. I., NAUMOVA, E. G., KISELEVA, E. V. 2013. Problems of optimization of innovation processes in organizations. In *Simulation, optimization and information technology*. 2013, no. 2, p. 10.
- [8] GUSKOVA, L. B. 2012. On the construction of the automated work place manager In *Successes of modern science*. 2012. no. 6, p. 106.
- [9] RODIONOVA, K. Yu. 2012. Globalization of the world economy: the nature and contradictions In *Herald of the Voronezh Institute of High Technologies*. 2012, no. , p. 185-186.
- [10] SHISHKINA, Yu. M., BOLUCHEVSKAYA, O. A. 2011. Public administration In *Recent studies of social problems*. 2011, vol. 6, no. 2, p. 241-242.
- [11] PENKOV, P. V. 2012. Expert methods to improve control systems In *Herald of the Voronezh Institute of High Technologies*. 2012, no. 9, p. 108-110.
- [12] RYAZHSKIY, A. M., PREOBRAZHENSKY, A. M., RYAZHSKIY, Yu. P., 2008. Construction of stochastic models of business processes optimization In *Herald of the Voronezh Institute of High Technologies*. 2008, no. 3, p. 79-81.

- [13] KOROLKOV, R. V. 2013. Controlling the trade organization. In *Herald of the Voronezh Institute of High Technologies*. 2013, no. 10, p. 287-290.
- [14] LISITSKY, D. S., PREOBRAZHENSKY, Yu. P. 2008. Building a simulation model of socio-economic system In *Herald of the Voronezh Institute of High Technologies*. 2008, no. 3, p. 135-136.
- [15] SAMOYLOVA, U. A., 2014. Some characteristics of the enterprise management In *Herald of the Voronezh Institute of High Technologies*. 2014, no. 12, p. 176-179.
- [16] KOROLKOV, R. V. 2013. On the financial management of the organization. In *Herald of the Voronezh Institute of High Technologies*. 2013, no. 11, p. 144-147.
- [17] KRAVTSOV, D. O., PREOBRAZHENSKY, Yu. P. 2008. Methods of optimal control of socio-economic system based on the adaptation In *Herald of the Voronezh Institute of High Technologies*. 2008, no. 3, p. 133-134.

Doc. Ing. Martin Šperka, PhD.

Pan-European University, Bratislava, Slovakia

Ing. Juraj Štefanovič, PhD.

Pan-European University, Bratislava, Slovakia

juraj.stefanovic@paneurouni.com

Prof. Igor Lvovich, D. Sc.

Pan-European University, Bratislava, Slovakia

office@vivt.ru



Modeling based on retrospective quantitative information processing via virtual expert resource

Juraj Štefanovič, Oleg Choporov

Abstract:

In modeling of complex systems, including objects with inhomogeneous characteristics, the effectiveness of the obtained models is strongly influenced by the applied methods of identification, focused on the similar system components. In this regard there is a need for the improved methods of identification of objects with inhomogeneous characteristics and the development of approaches to the quantitative evaluation of their quality characteristics. To solve this problem in the retrospective quantitative information processing, the use of expert and virtual resource, based on the interaction of an expert (s) and a computer system, is provided. An algorithm for building a mathematical model based on the combined use of expert and computer resources, is introduced. The approximate models obtained in that way are recommended to use in filling up the missing information at the preliminary stage of investigation and thinking of plenty of system development alternatives.

Keywords:

Objects with inhomogeneous characteristics, expert evaluations, expert and virtual resource, experiment planning, ranking.

ACM Computing Classification System:

Combinatorial algorithms, Algebraic algorithms, Nonalgebraic algorithms, Symbolic calculus algorithms, Exact arithmetic algorithms, Hybrid symbolic-numeric methods

Management quality and effective implementation of optimization models depend significantly on the identification techniques chosen in dependence of the features of single-type system components. Entities featuring inhomogeneous characteristics present a special class in that sense: being of identical physical nature and functional purpose they affect the experiment results differently as parts of models of managing complex systems.

Hence the need to upgrade theoretical foundations and principles of identifying and managing entities with inhomogeneous characteristics and develop approaches to quantitative assessment of qualitative characteristics.

The principles of identifying and managing entities with inhomogeneous characteristics were developed in publications [1, 2]. Traditionally, to study entities with inhomogeneous characteristics they resort to the class of techniques based on identifying and generalizing expert knowledge and opinions.

Publications mention mostly the technique of expert assessments (TEA) [3, 4] that has gained recognition during studies in planning R&D activities, engineering prognostic tasks of assessing the probable event occurrence time [5], tasks of factor ranging [6], and constructing global criteria [7]. Along with TEA they use the techniques of «brainstorming» the Delphi technique, the scenario approach, the «tree of goals», synectics, etc. [7]. Studies [1-4] demonstrate the possibility of using expert assessments to construct approximate mathematical models of complex entities via targeted polling of experts.

Study [8-10] reviewed the principle of identifying retrospective and expert information to obtain a mathematical description of dependence of indicators used for managerial decision making on varied variables.

In case it remains impossible to stage an active experiment and archive information is insufficient, it is suggested to use an individual prognostic virtual expert (IPVE), [1-4] to construct a mathematical model. The IPVE is used for preliminary definition of model structure. It is feasible to use the IPVE technique for poorly formalized problems in integrated environment of retrospective and expert information to assess the influence and direct effect of input variables and fill up the missing a priori information. Even a rough approximate assessment of regression factors for linear and paired interactions under the random balance technique calls for setting special experiments with the entity, and that may demand heavy expenditures. Meanwhile the suggested technique permits objective processing of subjective assessments of the state of complex entity by real experts and its numerical expression for a given situation.

Teams of real experts (TRE) include experts and scientists with large practical and scientific experience in handling the studied entity. Experts assess proposed situations not only subjectively but involving the a priori information available.

The technique of IPVE operation in integrated environment of retrospective and expert information follows these stages:

- 1) assessing expert competence;
- 2) forming teams of experts to participate in the experiment;
- 3) identifying input variables that affect significantly output variables;
- 4) selecting the model structure;
- 5) developing experiment plan;
- 6) designing questionnaires to poll experts;
- 7) dedicated polling of experts;
- 8) checking for expert agreement in assessing the situations envisaged by the experiment plan;
- 9) selecting the structure of mathematical model;
- 10) defining regression factors and assessing their statistical significance, testing the model adequacy;
- 11) testing the model experimentally against the current information on the normal functioning entity or against retrospective information, model adjustment following its experimental test;

12) interpreting the model for the entity.

Routinely, the ratings are calculated as arithmetic means over all the experts from their valuation of alternative options. Such an approach is quite acceptable when the degree of reliability and validity of TRE decisions has already been confirmed from problems previously solved. However managerial decisions are most often approved by the majority of votes by persons duly authorized to offer their opinions on particular issues, and subjective assessments cannot be considered or accepted on a par with those. The competency and consistency of experts shows in the spread of polling results. That is why it is recommended to initiate studies to identify most competent experts in their group and assess the consistency of opinions in advance of the experiment itself.

To understand experts' competency one may consider two approaches. One is the so-called self-competence or forced assessment of IPVE validity. When retrieving some group assessment one may introduce rating factors calculated on the basis of mutual assessment of competence by group members. It means that each i -th TRE member forms his/her own vector of preferences $\tilde{f}_i = \{a_j\}_{j \neq i}$, ranging other experts by their diminishing competence, as per his/her subjective assessment for the given problem. Then weight factors of competence are calculated for group members:

$$k_i = \frac{\sum_{j \neq i} a_i^j}{D-1}, \tag{1}$$

where a_i^j is the rank attributed to i -th expert by j -th expert;

D is the total number of experts.

Accordingly, the assessment on to each criterion ψ_l by i -th expert is normalized with the account of k_i and the TRE group assessment is calculated as

$$\sum_{i=1}^D \psi_l \cdot \left| 1 - \frac{\sum_{j \neq i} a_i^j}{D-1} \right| \tag{2}$$

The second way is to analyze the entity assessments. To have a more objective assessment, it is suggested, before taking dedicated polling, to get the opinion of experts on the direction in which input variables affect the more informative output variables of the entity and further have an assessment by DMP (or the dominating expert) of some objective indicator retrieved from processing the polling data. It is not the weight assessment of competence of each separate expert that is important in this case, but identifying the minimum team of experts capable further to forecast successfully the state of entity on the basis of certain combinations of input variables.

Initially the IPVE forms a complete list of input and output variables and ranges them. Ranging matrices containing related ranks are then reduced to their normal form, concordance factors calculated and their significance found using Pearson's χ^2 -criterion [11].

In the result of such processing of subjective data the relationship is formalized between significant input variables (factors) and each more informative factor for the entity:

$$y_i = f(x_1, \dots, x_n), \tag{3}$$

where n is the number of input variables (factors) that affect significantly the more informative i -th factor.

A questionnaire is put together on every more informative factor for the entity, and experts indicate the direction in which it is affected by each input variable following their subjective a priori information. The respective module of excess (decrease) within the

constraints set by the IPVE or the dominating expert then yields each expert's weight in competence and the following coefficients are calculated:

1) the expert activity coefficient [11]

$$\gamma = \frac{d_1}{D}, \quad (4)$$

where d_1 is the number of experts answering the question;

D is the total number of experts;

2) the inconsistency coefficient for each κ -th input variable and i -th more informative factor for the entity:

$$\eta_{\kappa_i} = \frac{d_{2i}}{d_{3i}}, \quad (5)$$

where d_2, d_3 are the numbers of experts giving opposing answers ($d_3 > d_2$), respectively;

3) the variation coefficient for the sum of ranks from the assessment of expert weights

$$V = \frac{S_{a_i^j}}{\bar{a}_i^j}, \quad (6)$$

where a_i^j is the value of sum of ranks for i -th expert in the opinion of j -th expert;

\bar{a}_i^j is the average sum of ranks for the group of experts;

$S_{a_i^j}$ is the RMS deviation of the sum of ranks a_i^j .

The lower the inconsistency coefficient, the higher is the overall experts' confidence in their assessment of influence of the κ -th input variable. The activity coefficient yields a proxy characteristic of competence of the group of experts: if $\gamma = 0$ experts are incompetent and incapable to assess the process mechanisms. The variation coefficient V characterizes the level of competence of the group as a whole. The suggested technique of forced assessment (ranging) of competence of the group of experts is combined with objective indicators thus decreasing subjectivity of assessments typical for straightforward screening of experts.

To range input variables, the number of experts should be $D \geq 7$, and $D \geq 3$ for dedicated polling of experts [11-14].

Upon screening the insignificant input variables and identifying the more informative factors for the entity, one organizes collecting a priori data while meeting the necessary prerequisites for the coming active experiment. Using the IPVE one constructs the approximate mathematical model of entity according to subjective information.

Following equation (3) one designs the plan of active experiment; experts define the value of output variable (of the more informative factor of the process) for those states of the system that correspond to matrix lines. Apparently, the plan of experiment shall be fully randomized. The polling questionnaire describes the plan of experiment with the upper and lower basic levels of input variables indicated and the necessary constraints set.

Upon implementing the plan of experiment, the agreement is tested of expert assessment of the situation for each i -th line of the matrix using the data obtained. It is suggested to use the technique of rank correlation with Cochran F -criterion for the purpose. Assume a full factor experiment (FFE) was conducted resulting in several parallel essays d , their number equal to the number of expert opinions. For each j -th column ($j = 1, 2, \dots, N$) of values of output variable we do the ranging to find the value [11, 15, 16]

$$f = A - a_i^j, \tag{7}$$

where A is the highest rank;

a_i^j is the rank attributed to i -th line of planning matrix according to j -th column.

First we reduce the table of ranges to its normal form in case “related ranks” are present [16, 17] and plot a visualization diagram, its abscissas showing the numbers of the forecast matrix lines and the ordinates being their respective values of f . Naturally, disagreements are possible between separate qualitative assessments of matrix lines among the experts. Their consistency is assessed as following.

First, the respective variance is estimated [11-13]

$$S_{vosp}^2 = \frac{\sum_{i=1}^D S_i^2}{D-1}, \tag{8}$$

$$i = 1, \dots, D$$

for each matrix line, where S_i^2 is the estimated variance of output variable for i -th line:

$$S_i^2 = \frac{\left(f_i - \bar{f}_i \right)^2}{D-1}; \tag{9}$$

\bar{f}_i is the average value of rank, attributed to i -th line:

$$\bar{f}_i = \frac{f_1 + f_2 + \dots + f_D}{D}. \tag{10}$$

Then the maximum estimated variance of ranging, $S_{vosp_{max}}^2$ is found, plus the sum of assessed variances $\sum_{j=1}^N S_j^2 (j = 1, 2, \dots, N)$, where N is the number of lines in the planning

matrix. Next the value is found of Cochran’s Γ -criterion. In case $G_{rach} < G_{krit}$ of the number of degrees of freedom, the hypothesis is accepted of homogeneous variances of ranging and consistency of experts in assessing situations in the planning matrix. If experts are found consistent in understanding these situations, the regular procedure is executed of retrieving regression coefficients for that assessment, testing their statistical significance and the adequacy of the obtained regression equation to the data of dedicated polling [1-4].

Next one tests experimentally the obtained mathematical description of entity against the data collected in the normal operation mode or its retrospective data. Note that the result of testing the model adequacy against experimental data with the use of Fischer’s F -criterion being positive, the mathematical model may still contain a constant bias due to mutually compensated errors in expert assessments of output variables of the studied entity. That bias is excluded in the course of experimental test of the model [5-7].

Mathematical models yielded by the IPVE techniques operating in integrated environment of retrospective and expert information are considered to be approximate, used to retrieve lacking data during preliminary studies. They serve to form sets of alternative options of system development. The procedure used to construct mathematical model of entity based on processing retrospective quantitative information is shown in figure 1.

The proposed procedure for building a mathematical model of an object can be used in addressing a wide range of advanced application problems and it has been included in the developed software system of managerial decision making support in the public sector

for organization of tendering procedure expert evaluation and in management of sectorial complexes project activity.

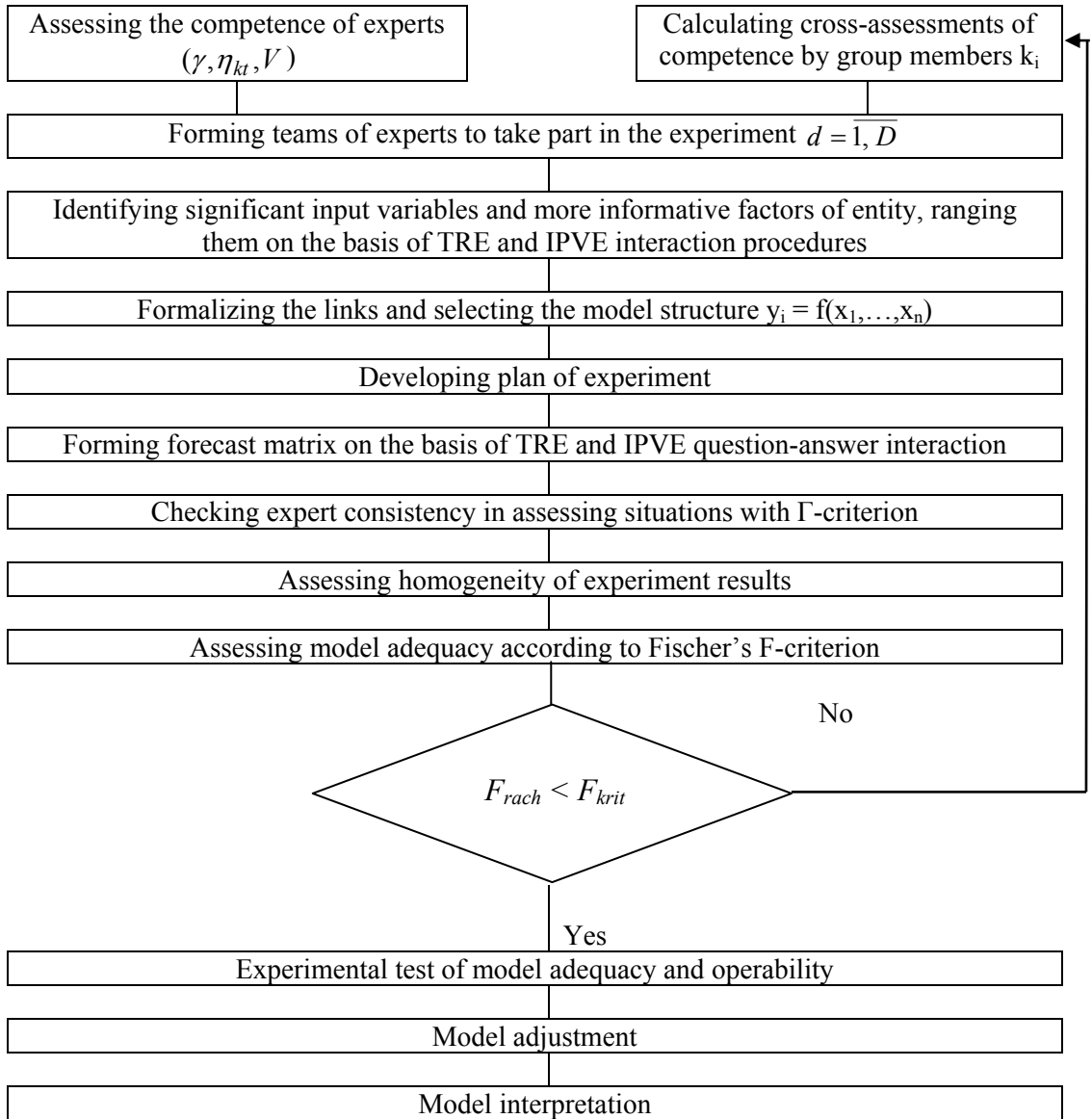

Figure 1. Constructing the mathematical model to assess retrospective quantitative information

References

- [1] ŠPERKA, M. 2015. Special aspects and principles of identification of objects with inhomogeneous characteristics. In: *Information Technology Applications*. 2015, no. 1, p. 3-12.
- [2] SCHINDLER, F. 2015. Algorithmization of decision-making in management of objects with inhomogeneous characteristics. In: *Information Technology Applications*. 2015, no. 1, p. 13-22.
- [3] LVOVICH, I. 2015. Structurization of an expert and virtual resource of the cor-

- porate intellectual capital in the environment of adoption of administrative decisions. In: *Information Technology Applications*. 2015, no. 1, p. 23-32.
- [4] RUŽICKÝ, E. 2015. Formalization of user interaction with virtual expert resource of knowledge type via ontological modeling. In: *Information Technology Applications*. 2015, no. 1, p. 33-43.
- [5] PREOBRAZHENSKY, Yu., P., PANEVIN, R., Yu. 2010. The wording and classification of problems of optimal control production facilities. In: *Bulletin of Voronezh State Technical University*. 2010, vol. 6, no. 5, p. 99-102.
- [6] CHOPOROV, O., N., CHUPEEV, A., N., BREGEDA, S., Y. 2008. Significance Methods of analysis parameters in the classification and predictive modeling. In: *Bulletin of Voronezh State Technical University*. 2008, vol. 4, no. 9, p. 92-94.
- [7] MOSKALCHUK, Yu., I., NAUMOVA, E., G., KISELEVA, E., V. 2013. Problem optimization of innovation processes in organizations. In: *Simulation, optimization and information technology*. 2013, no. 2, p. 10.
- [8] GUSKOVA, L., B. 2012. On the construction of the automated work place manager. In: *Successes of modern science*. 2012, no. 6, p. 106.
- [9] RODIONOVA, K., Yu. 2012. Globalization of the world economy: the nature and contradictions. In: *Herald of the Voronezh Institute of High Technologies*. 2012, no. 9, p. 185-186.
- [10] SHISHKINA, Yu., M., BOLUCHEVSKAYA, O., A. 2011. Public administration. In: *Recent studies of social problems*. 2011, vol. 6, no. 2. p. 241-242.
- [11] PENKOV, P., V., 2012. Expert methods to improve control systems. In: *Herald of the Voronezh Institute of High Technologies*. 2012, no. 9, p. 108-110.
- [12] RYAZHSKIY, A., M., PREOBRAZHENSKY, Yu., P. 2008. Construction of stochastic models of business processes optimization. In: *Herald of the Voronezh Institute of High Technologies*. 2008, no. 3, p. 079-081.
- [13] KOROLKOV, R., V. 2013. Controlling the trade organization. In: *Herald of the Voronezh Institute of High Technologies*. 2013, no. 10, p. 287-290.
- [14] LISITSKY, D., S., PREOBRAZHENSKY, Yu., P. 2008. Building a simulation model of socio-economic system. In: *Herald of the Voronezh Institute of High Technologies*. 2008, no. 3, p. 135-136.
- [15] SAMOYLOVA, U., A. 2014. Some characteristics of the enterprise management. In: *Herald of the Voronezh Institute of High Technologies*. 2014, no. 12, p. 176-179.
- [16] KOROLKOV, R., V. 2013. On the financial management of the organization. In: *Herald of the Voronezh Institute of High Technologies*. 2013, no. 11, p. 144-147.
- [17] KRAVTSOV, D., O., PREOBRAZHENSKY, Yu., P. 2008. Methods of optimal control of socio-economic system based on the adaptation. In: *Herald of the Voronezh Institute of High Technologies*. 2008, no. 3, p. 133-134.

Ing. Juraj Štefanovič, PhD.

Pan-European University, Bratislava, Slovakia
juraj.stefanovic@paneurouni.com

Prof. Oleg Choporov, D. Sc.

Voronezh Institute of High Technologies
choporov_oleg@mail.ru



Modeling of a numeracy of dominant options of multialternative optimization

Igor Lvovich, Juraj Štefanovič

Abstract:

One of the problems arising in management of large systems, is a selection of the best management options. To solve this problem an approach that allows to generate a numeracy of perspective options for managerial decisions is proposed. Development of a numeracy of dominant options of managerial decisions is based on the application of basic algorithmic procedures of variation modeling and building of multiple-optimization models. To use basic algorithmic procedures of variation modeling, the typical tasks are highlighted and their formalization with inclusion of alternative variables, allowing to develop a numeracy of perspective options through the variability of indicators, is performed. At that the problem of dichotomous reduction arises. Integration of all stages of decomposition and equivalent transition to analytical optimization models into a single scheme allowed to define a method of mathematical modeling of dichotomous reduction of complex systems diversity. To identify the dominant option, an algorithm that combines computational procedures for determination of the preference vector and the rational choice procedures, is developed.

Key words:

Simulation modeling, multialternative optimization, dichotomous reduction, rational choice, decision support.

ACM Computing Classification System:

Combinatorial algorithms, Algebraic algorithms, Nonalgebraic algorithms, Symbolic calculus algorithms, Exact arithmetic algorithms, Hybrid symbolic-numeric methods.

Introduction

In handling the problem of large systems management there is a problem of analysis, evaluation, comparison of alternative numeracy of options on a number of a variety of divergent criteria as a general principle. To formalize this problem, the theory of decision-making is used. However, the standard developed methods are not always effective in solving large-scale problems. It requires improvement of existing and development of new algorithms, including combined algorithms. In particular, one of the perspective areas of research is the use of variation modeling procedures and multialternative optimization techniques.

1. Formalization of typical tasks of development of a numeracy of perspective options

To use such algorithmic procedures of variational modeling based on multi-alternative optimization models one needs to identify typical problems and formalize them including alternative variables z_m that make it possible to form sets of prospective options according to factor variations.

Consider the basic class of problems $\overline{\beta_1, \beta_4}$ [1].

We substantiate the problems (β_1, β_4) and calculate the respective a priori entropy $H(l, p^1) = \lg L$.

1. Problem β_1 consists in dividing the sets $w_g = \overline{1, W_g}$ into two groups, one of them forming sub-sets $\hat{W}_g \in W_g$, that meet requirements $F_i^*, i = \overline{1, I}$. Such a division results in the following number of options available for selection:

$$L = 2^{W_g}, g = \overline{1, G}. \quad (1.1)$$

The a priori entropy of each g -th problem is

$$H_g(\beta_1) = W_g \lg 2, g = \overline{1, G}. \quad (1.2)$$

2. Problem β_2 consists in selecting a single element in each sub-set $\overline{1, \hat{W}_g}, g = \overline{1, G}$ following the requirements $F_i^*, i = \overline{1, I}$. The number of options for selection is then

$$L = \prod_{g=1}^G \hat{W}_g,$$

the respective a priori entropy being

$$H(\beta_2) = \sum_{g=1}^G \lg \hat{W}_g. \quad (1.3)$$

3. Problem β_3 consists in ranging options W_g according to index g , i.e. in selecting the order of antecedence of elements $w_g < w_t; g \neq t; g, t \in \overline{1, T}$; sign “<” indicates that element t follows after element g . The problem considered is related to either defining the position of element w in the sequence $\overline{1, T}$, or to defining the order of proceeding from the initial element number $t=0$ to the following elements numbered $t>0$. The number of options for selection is $L = T!$

To assess the value of a priori entropy for any integer $T \geq 6$ we use the inequality [1]:

$$\left(\frac{T}{2}\right)^T > T! > \left(\frac{T}{3}\right)^T,$$

then $T \lg \frac{T}{2} > H(\beta_3) > T \lg \frac{T}{3}$.

4. Problem β_4 consists in merging together elements with numbers $g = \overline{1, G}$ into the $g' = \overline{1, G'}$ group. The number of options for it is:

$$L = (G')^G,$$

and the a priori entropy is:

$$H(\beta_4) = G \lg G'. \quad (1.4)$$

To assess the entropy of dichotomic optimization model we assume that it coincides with the entropy of test A corresponding to Boolean structures (μ) , i. e.

$$H(\mu) = H(A).$$

We now calculate the value of entropy for the disjunctive test $A_m = (m = \overline{1, M})$:

$$H(A_m) \leq \lg N_m,$$

where the equality sign corresponds to equal probabilities of results $P(A_{mn}) = \frac{1}{N_m}$.

The entropy of a complex test A :

$$H(A) = H(A_1 \dots A_m \dots A_M) \leq H(A_1) + \dots + H(A_m) + \dots + H(A_M) \leq \sum_{m=1}^M \lg N_m.$$

If $N_1 = \dots = N_m = \dots = N_M = N$, then $H(A) \leq M \lg N$.

In case $N_m = 2 \forall m = \overline{1, M}$

$$H(A) \leq M \lg 2.$$

2. Conditions of dichotomous optimization model adequacy and set-theoretical statement of a problem

Thus we have computational formulas to assess the a priori entropy for problems (β_1, β_4) and the entropy of Boolean structures within the scope of model μ . We now formulate the conditions of correspondence between these values. We shall call them conditions for adequacy of dichotomic optimization model and theoretical multiple setting of the problem.

The dichotomic optimization model (μ) describes the problem (β) adequately in case the outcome of test A determines fully the outcome of problem (β) .

Theorem: For dichotomic optimization model to describe adequately problem (β) it is necessary and sufficient to meet the following condition:

$$H(\beta) \leq H(\mu). \quad (2.1)$$

Let us prove its necessity. Test A taken according to model (μ) makes it possible to obtain information on problem (β) :

$$I(A, \beta) = I(\mu, \beta) = H(\beta) - H_\beta(\mu),$$

where $H_\mu(\beta)$ is the entropy of problem (β) in case test A is taken following model (μ) .

On the other hand:

$$I(\beta, \mu) = H(\mu) - H_\beta(\mu),$$

where $H_{\beta}(\mu)$ is the entropy of test A corresponding to the respective model (μ) for the outcome of problem (β).

Since

$$I(\mu, \beta) = I(\beta, \mu),$$

we have

$$H(\beta) - H_{\mu}(\beta) = H(\mu) - H_{\beta}(\mu). \tag{2.2}$$

In case condition (2.1) is met, we may proceed from (6) to inequality

$$H_{\mu}(\beta) \leq H_{\beta}(\mu). \tag{2.3}$$

Since $H_{\beta}(\mu)$ may be equal to 0, inequality (2.3) is only satisfied in case $H_{\mu}(\beta)=0$. It means that the outcome of test A defines fully the outcome of problem (β) and dichotomic optimization model (μ) describes problem (β) adequately.

Now we proceed to prove sufficiency. If model (μ) describes the problem (β) adequately then $H_{\mu}(\beta) = 0$. It follows from (2.2) then:

$$H(\beta) = H(\mu) - H_{\beta}(\mu).$$

Finally we have

$$H(\beta) \leq H(\mu),$$

Q. E. D.

This theorem makes it possible to find dimensionality and structure of dichotomic optimization model (μ) for problems (β_1, β_4) .

Rule 1. Dimensionality of dichotomic optimization model (μ_1) adequate to problem (β_1) is:

$$M = W_g (g = \overline{1, G}) \tag{2.4}$$

A model inducting the test for $N_m = 2, \forall m = \overline{1, M}$ corresponds to problem (β_1). Then it follows from condition (2.1) with the account of (1.2) that $H_j(\beta_1) = W_g \lg 2 \leq H_j(\mu_1) \leq M \lg 2, M = W_g (g = \overline{1, G})$.

Following (2.4) we introduce Boolean variables of multi-alternative optimization model:

$$W_g^1 = \begin{cases} 1, & \text{in case element } i \text{ is included in the ensemble} \\ 0, & \text{in the opposite case} \end{cases} \quad \hat{W} \in W,$$

$$(w_g = \overline{1, W_g}).$$

Next we find the structure of objective function and model constraints for the task of forming the admissible set $\hat{W} \in W$. For that purpose we construct the matrix $a = \|a_{wg}\|$, assuming that

$$a_{wg} = \begin{cases} 1, & \text{in case element } W_g \text{ meets the choice for the } i\text{-th factor element,} \\ 0, & \text{in the opposite case} \end{cases},$$

$$(w_g = \overline{1, W_g}, i = \overline{1, I}).$$

In case one needs to find the minimum set $1, \hat{W}_g$, optimization model is presented as the problem of minimum coverage [2]:

$$\sum_{w_g}^{W_g} x_{wg}^1 \rightarrow \min,$$

$$\sum_{w_g=1}^{W_g} a_{i w_g} x_{wg}^1 \geq 1, (i = \overline{1, I}),$$

$$x_{wg}^1 = \begin{cases} 1, & (w_g = \overline{1, W_g}) \\ 0, & \end{cases}$$

In certain situations the available information is insufficient to construct the matrix $\|a_{i w_g}\|$. One may only indicate the “value” a_{ij} of element w_g with respect to factor $F_i (i \in I_1)$, in other words – set the constraint $C_i (i \in I_2)$ with the account of “weight” characteristics $c_{i w_g}$ of separate elements. Then the optimization model is reduced to a multidimensional knapsack problem [2]:

$$\sum_{w_g=1}^{W_g} a_{w_g} x_{wg}^1 \rightarrow \max,$$

$$\sum_{w_g=1}^{W_g} c_{i w_g} x_{wg}^1 \leq C_{w_g}, (i = \overline{1, I_2}),$$

$$x_{wg}^1 = \begin{cases} 1, & (w_g = \overline{1, W_g}) \\ 0, & \end{cases}$$

Rule 2. Dimensionality of optimization models (μ_2), adequate to problem (β_2) is:

$$\text{a) } M = G, N_m^R = \hat{W}_g (m = \overline{1, G}), \quad (2.5)$$

$$\text{b) } M = \sum_{g=1}^G \frac{\lg \hat{W}_g}{\lg 2}, \quad (2.6)$$

$$N_m = 2, \forall m = \overline{1, M}.$$

In the first case we assume that model (μ_2) inducts a complex test A with its entropy meeting the general condition. Accounting for (1.3) and (2.1) we have then:

$$H(\beta_2) = \sum_{g=1}^G \lg \hat{W}_g \leq H(\mu_2) \leq \sum_{m=1}^M \lg N_m.$$

Expression (2.5) follows unambiguously then.

Following (2.5) we introduce Boolean variables for the dichotomic optimization model. Then

$$x_{wg} = \begin{cases} 1, & \text{if } w_g \in \hat{W} \text{ provides for meeting the conditions } , i = \overline{1, I}, \\ 0, & \text{in the opposite case.} \end{cases}$$

$$(w_g = \overline{1, W_g}, g = \overline{1, G}).$$

Since complex test A is disjunctive over index n , the set of Boolean variables has to meet the following constraints for a given m :

$$\sum_{w_g} \hat{W}_g x_{wg} = 1, (g = \overline{1, G})$$

In the second case we assume that model (μ_2) indicates a complex test A for $N_m = 2, \forall m = \overline{1, M}$. With the account of (10) it follows from condition (2.1) then

$$H(\beta) = \sum_{g=1}^G \lg \hat{W}_g \leq H(\mu_2) \leq M \lg 2.$$

And relation (2.6) follows from it.

To introduce Boolean variables corresponding to (2.6), one needs to present elements of the set \hat{W} in their binary denomination. E. g., we have for $\hat{W}_g \leq 8, \forall g = \overline{1, G}$:

$$\begin{aligned} w_1 &= x_1 + 2x_2 + 4x_3, \\ &\vdots \\ w_G &= x_{M-2} + 2x_{M-1} + 4x_M, \end{aligned}$$

where

$$x_m = \begin{cases} 1, \\ 0, \end{cases} (m = \overline{1, M}).$$

Finally optimization models (μ_2) adequate to problem (β_2) are presented in the form of multi-criteria optimizing problems with Boolean and continuous variables. For case (a): $\Psi_i(x_{wg}) \rightarrow \max, (i \in I_1)$,

For case (b):

$$\begin{aligned} \Psi_i(x_m) &\rightarrow \max, (i \in I_1), \\ x_m &= \begin{cases} 1, \\ 0, \end{cases} (m = \overline{1, M}). \end{aligned}$$

Since numbers \hat{W}_g coincide with values $2^k (k = 0, 1, 2, \dots)$, numbers of fictitious w_ϕ correspond to certain sets of x_m . For them we introduce such functions $\varphi_i(w_\phi)$, for which the requirement $F_i^*, i = \overline{1, I}$ is deliberately not met.

Rule 3. Dimensionality of dichotomic optimization models (μ_3) adequate to problem (β_3) is:

$$M = T, N \geq \frac{T}{2}.$$

Model (μ_3) inducts a complex test A , its entropy meeting the general condition. Then with the account of (2.1) we have:

$$T \lg \frac{T}{2} > H(\beta_3) < H(\mu_3) \leq M \lg N$$

That inequality is met for $M = T, N \geq \frac{T}{2}$, in particular, for $N = T$.

As indicated above, the order of antecedence of elements merged into a complex system is set in two ways:

a) an ordered sequence of numbers is set from the list of numbers $S - n = \overline{1, T}$ and each number has its corresponding m -th $(m = \overline{1, T})$ element from the list (s) ;

b) the initial element ($m = 0$) is specified, and one needs to find an optimal route for transition from element to element belonging to list s_1 , eventually returning to initial elements.

We introduce Boolean variables for the first case:

$$x_{mn} = \begin{cases} 1, & \text{if element } w_n^* \text{ is attributed its } m\text{-th number in list } s_l \\ 0, & \text{in the opposite case} \end{cases}$$

$$(m = \overline{1, T}, n = \overline{1, T}).$$

Each option of the sequence has a corresponding value of some particular factor for the system $F = \Psi(x_{mn})$. In the result we have a dichotomic optimization model of the type of Assignment Problem [2, 3]:

$$F = \Psi(x_{mn}) \rightarrow \text{extr},$$

$$\sum_{m=1}^T x_{mn} = 1, \quad (n = \overline{1, T}),$$

$$\sum_{n=1}^T x_{mn} = 1, \quad (m = \overline{1, T})$$

$$x_{mn} = \begin{cases} 1, & (m = \overline{1, T}, n = \overline{1, T}) \\ 0, & \end{cases}$$

In the second case we associate Boolean variables with alternatives to the transition from m -th to n -th element:

$$x_{mn} = \begin{cases} 1, & \text{in case the antecedence relation is met } Vm < Vn, \\ 0, & \text{in the opposite case} \end{cases}$$

$$(m = \overline{0, T}, n = \overline{0, T}).$$

Certain values of a particular factor $f = f(x_{mn}) (m = \overline{0, T}, n = \overline{0, T})$, the factor $F = \Psi(f(x_{mn}))$ related to them, correspond to transitions from one element to the other. Then the optimization model acquires the structure typical for the Travelling Salesman's Problem [2-4]:

$$F = \Psi(f(x_{mn})) \rightarrow \text{extr},$$

$$\sum_{m=0}^T x_{mn} = 1, \quad (n = \overline{1, T}),$$

$$\sum_{n=0}^T x_{mn} = 1, \quad (m = \overline{1, T})$$

$$\pi_m - \pi_n + T x_{mn} \leq T-1,$$

$$(m = \overline{1, T}, n = \overline{1, T}, m \neq n),$$

$$x_{mn} = \begin{cases} 1, & (m = \overline{0, T}, n = \overline{0, T}), \\ 0, & \end{cases}$$

where π_m, π_n are arbitrary real values.

Rule 4. Dimensionality of dichotomic optimization models (μ_4), adequate to problem (β_4):

$$M = G, N \geq G'.$$

Model (μ_4) inducts a complex test (A) , its entropy meeting the general condition. Then with the account of (4) we have:

$$H(\beta_4) = G \lg G' \leq H(\mu_4) \leq M \lg N .$$

That inequality is met for $M = G, N \geq G'$.

We introduce Boolean variables for model (μ_4) :

$$x_{mn} = \begin{cases} 1, & \text{in case the } m\text{-th element is attributed to the } n\text{-th group} \\ 0, & \text{in the opposite case.} \end{cases}$$

$$(m = \overline{1, G}, n = \overline{1, G'}) .$$

The optimal division into groups is characterized by some particular factor F that is a function of parameters $f(V_m)$ and variables x_{mn} . Note that in model (μ_4) each element W_m may only belong to a single group. Besides, there exists an antecedence order of elements $(V_g < V_m, g = \overline{1, G}, m = \overline{1, G}, g \neq m)$ [5-7]. Finally we arrive at the following multi-alternative optimization model:

$$\begin{aligned} F &= \Psi(f(V_m), x_{mn}) \rightarrow \text{extr} , \\ \sum_{n=1}^{G'} x_{mn} &= 1, (m = \overline{1, G}), \\ V_g &< V_m, (g = \overline{1, G}, m = \overline{1, G}, g \neq n, \\ x_{mn} &= \begin{cases} 1, \\ 0, \end{cases} (m = \overline{1, G}, n = \overline{1, G'}) . \end{aligned}$$

Therefore, problems of multi-alternative aggregation that belong to class (β) are brought in correspondence with their adequate analytical optimization models.

3. Method of mathematical modeling of dichotomous reduction of complex systems diversity

Merging all the stages of decomposition and equivalent transition to analytical optimization models into a common scheme makes it possible to formulate a technique for mathematical modeling of dichotomic reduction of diverse complex systems that includes the following procedures:

1. Define the composition of local problems (β) : decomposition.
2. Assess the a priori entropy of problems (β) : $H(\beta)$.
3. Shape preliminarily the dichotomic optimization model (μ) .
4. Assess the entropy $H(\mu)$ of a complex test corresponding to that dichotomic optimization model.
5. Assess the adequacy condition.
6. Set the final structure and dimensionality of the dichotomic optimization model following Rules 1 – 4.

The links between those stages are shown in the structural flowchart (fig. 1). A special feature of solving numerically the above problems of multi-alternative optimization consists in that all their listed types (free of constraints, having algorithmically described constraints or constraints of general type and multi-criteria problems) are solved within the scope of a single scheme.

It is implemented via the following set of algorithmic procedures [1]:

- 01 – generate admissible problem solution;
- 02 – tune the distribution laws for alternative variables;
- 03 – form computed prognostic assessments (V_{rasc});
- 04 – define the order of setting disjunctive tests;
- 05 – form prognostic expert assessments (V_{exp});
- 06 – account for general constraints and multi-criteriality.

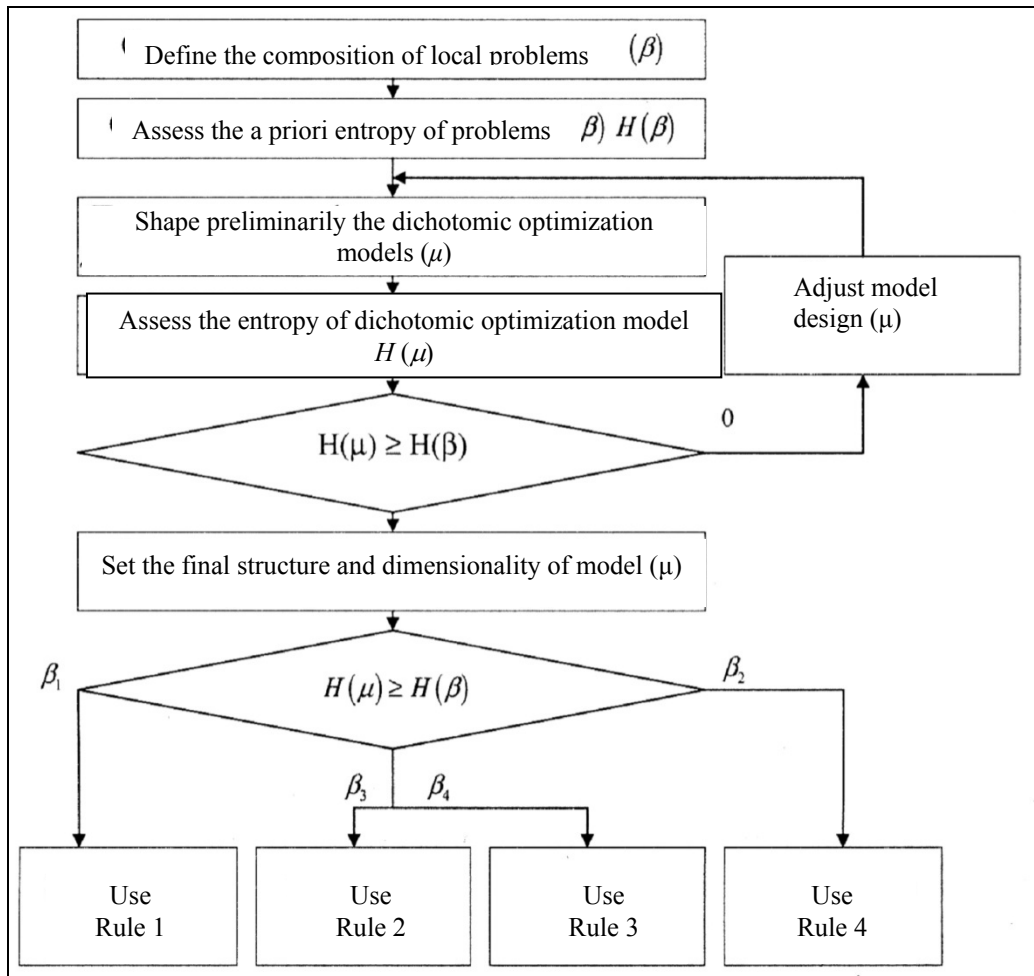

Figure 1. Structural flowchart of mathematical modeling of the process of dichotomic reduction

4. Rational choice method on a numeracy of complex systems ranked options

Algorithmic procedures ($\overline{\theta_1, \theta_6}$) make it possible to search through the set of alternative variables of optimization models. We demonstrate the possible organization of rational selection on the set of ranged options of complex systems that we shall call identifying the dominating option. We interpret the process of transiting from one optional solution to another, related to algorithmic procedures of multi-alternative optimization, as taking a chance path that corresponds to some finite Markov chain [2] with its variable transition matrix:

$$p^k = \left\| p_{l\omega}^l \right\|, (l = \overline{1, L}, \omega = \overline{1, L}, k = 1, 2, \dots). \tag{4.1}$$

Consider some of its properties that make it possible to proceed from the distribution of random Boolean variables to the vector of preferential options.

In case of a multi-alternative optimization model of dimensionality $(M, N = 2)$ and algorithmic procedures $(\theta_3), (\theta_4)$, we may proceed from a certain situation with its vector $x^l = \{x_m^l\}$, characterizing option $l \in \overline{1, L}$, to situation M belonging to $(L-1)$ others, or remain in the initial situation. Then elements of the transition matrix (4.1) are calculated as following:

$$p_{l\omega}^k = \sum_{M-1}^m |x_{m\omega} - x_{ml}| p^k(x_m = x_{m\omega}) p_m^k + \aleph_1(|x_{m\omega} - x_{ml}|) p^k(x_m = x_{m\omega}) p_m^k \times \tag{4.2}$$

$$\times \left[\aleph_2 \left(\sum_{M-1}^m |x_{m\omega} - x_{ml}| \right) \right], (l \neq \omega, l, \omega \in \overline{1, L}), p_{ll}^k = \sum_{M-1}^m p^k(x_m = x_{ml}) p_m^k, l = \overline{1, L},$$

where $p^k(x_m = x_{m\omega})$ is the probability for Boolean variable x_m to obtain its value $x_{m\omega}$, corresponding to the ω -th situation;

$$\aleph_1(x) = \begin{cases} 1, & \text{if } x = 0 \\ 0, & \text{if } x = 1 \end{cases} \quad \aleph_2(x) = \begin{cases} 1, & \text{if } x = 0 \\ 0, & \text{if } x \neq 1 \end{cases}$$

In case dimensionality of the dichotomic optimization model is (M, N) and there is a constraint $\sum_{n=1}^N x_{mn} = 1$, then, according to (θ_4) the process of taking the chance path should be considered separately for each vector $x_m = (x_{m1}, \dots, x_{mn}, \dots, x_{MN})$. One may proceed then from situation with its vector $x_m = (x_{m1} = 0, \dots, x_{mn} = 1, \dots, x_{MN} = 0)$ to $(N-1)$ other situations or remain in the initial situation. The elements of transition matrix (4.1) are calculated as:

$$p_{l\omega}^k = p_{xmn}^k \tag{4.3}$$

Let us demonstrate the regularity of Markov chain with elements (12) of the transition matrix. It is known [1] that the transition matrix is regular when all matrix elements $(P_k)^\alpha$ are different from 0 for some integer $\alpha > 0$.

The number α means the number of steps needed to transit from one state to the other. According to (4.2) for $\alpha = 1$ one may transit from l -th situation to $(M+1)$ other situations at a probability different from zero, i. e. the number of elements $p_{l\omega}^k$, different from zero in each line and each column of matrix p^k is equal to $(M+1)$. The minimum number of steps over which the transition from l -th situation to $(L-1)$ other situations is possible with non-zero probability is $\alpha = M$, and the transition matrix with elements (4.2) put to the power of $\alpha = M$ contains no elements equal to 0. Hence, it is regular, and the respective Markov chain is also regular.

Elements (4.3) of the transition matrix are not equal to zero for $\alpha = 1$, hence in case

of dichotomic optimization model and (M, N) algorithmic procedures they generate a regular Markov chain.

For each k -th iteration the properties of a regular Markov chain [2] make it possible to retrieve analytically the components of vector $q = (q_1, \dots, q_l, \dots, q_L)$ on the basis of transition matrix. We start with its following properties:

1. Transition matrix put to the power of α $((P)^\alpha)$ tends to the probability matrix T for $\alpha \rightarrow \infty$.

2. Each line of matrix T presents one and the same probability vector $t = (t_1, t_2, \dots, t_l, \dots, t_L)$, all its components positive while $\sum_{l=1}^L t_l = 1$.

3. The rate of convergence of $(P)^\alpha$ to its limit T is exponentially fast, and matrices $(P)^\alpha$ and T remain close to each other for relatively small values of α .

4. Vector t is the only vector for each $tP = t$.

5. For any initial distribution of options

$$m(u_l^\alpha) \rightarrow t_l \text{ for } \alpha \rightarrow \infty,$$

where u_l^α is the share of time spent by the Markov process in state $l = \overline{1, L}$ (over the first α steps).

The first four properties are used to calculate the coordinates of vector $t = \{t_1, \dots, t_l, \dots, t_L\}$ by putting matrix P^k to the power of $\alpha > M$ or by solving the system of linear equations $tP = t$. The last property makes it possible to equate the values of vector q^k coordinates to the coordinates of vector t , i.e.

$$q_l^k = t_l. \tag{4.4}$$

Let us demonstrate that probabilities calculated after (4.4) are truly the quantitative assessments of selection probabilities which meet certain conditions of rational selection.

The above Markov chain with its set of states $s_l, (l = \overline{1, L})$ and transition probabilities $p_{l\omega}, l = \overline{1, L}, \omega = \overline{1, L}$ features the necessary properties [8] making it possible to look at values q_l^k as a quantitative assessment of selection probabilities $P(s_l : S)$ that meet the principle of sequential narrowing. Besides, these assessments agree with the theory of probabilistic ranging [1, 8], i.e., they not only characterize the probability of selecting option s_l from set S , but that of selecting it in the first place.

Following that reasoning, the complex system S_ω optimal on set S is such that

$$P(s_\omega : S) = \max \left\{ P \left(s_\omega : S \right) \right\}_{l=1, L} \tag{4.5}$$

However, dealing with a multi-alternative optimization model μ that serves as the basis for automatic search procedures, it often appears impossible to formalize all the constraints related to synthesizing a complex system. To account for non-formalized

constraints, a DMP is involved. Probabilities q_l are treated as probabilistic ranks then. It is suggested for decision-maker to consider some group L^* of highest ranks instead of a single option corresponding to condition (4.5). Rational selection is once again implemented following the principle of consequential narrowing on set $l = \overline{1, L}$, but now it goes with the account of qualitative factors that remained non-formalized in model μ .

Distribution (4.4) is used to identify the dominating option while achieving prescribed quality against a certain condition. The entropy function entering such a condition is averaged. Therefore, the values $H(l, q^k)$ may appear equal to each other for different distributions q^k (fig. 2).

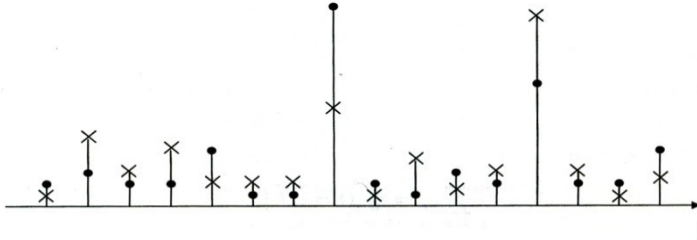

Figure 2. Distribution q of probabilities to select options of a complex system.
 (• is the distribution $q^{k+\aleph} = \eta^1$; × is the distribution $q^{k+(\aleph-1)} = \eta^2$)

One should recourse to the procedures of rational selection when the series of \aleph ($\aleph=1,2,\dots$) iterations of distribution $q^{k+\aleph}$ are identical to each other. To assess such a situation, consider the formal description of preference using fuzzy relations [1].

Consider the distribution $\eta^1 = q^{k+\aleph}$ ($\aleph=1,2,\dots$) for $\eta^2 = q^{k+(\aleph-1)}$. How does one estimate quantitatively whether η^2 is not in preference to η^1 using the value:

$$\alpha_{\eta^1 \sim \eta^2} = 1 - (\alpha_{\eta^1 \eta^2} + \alpha_{\eta^2 \eta^1}),$$

where $\alpha_{\eta^1 \eta^2}$ is the degree of strict preference of η^1 over η^2 ;

$\alpha_{\eta^2 \eta^1}$ is the degree of strict preference of η^2 over η^1 .

If distributions $\eta^1 = (\eta^1_1, \dots, \eta^1_l, \dots, \eta^1_L)$ and $\eta^2 = (\eta^2_1, \dots, \eta^2_l, \dots, \eta^2_L)$ are known, calculating the values of α follows the formulas:

$$\alpha_{\eta^1 \sim \eta^2} = \sum_{l=1}^L \zeta_{ll}, \quad \alpha_{\eta^1 \eta^2} = \sum_{l < t} \zeta_{tl}, \quad \alpha_{\eta^2 \eta^1} = \sum_{l > t} \zeta_{lt}$$

where ζ_{lt}, ζ_{tl} ($l = \overline{1, L}, t = \overline{1, L}$) are solutions for the problem of linear programming:

$$\sum_{l=1}^L \sum_{t=1}^L \zeta_{lt} |u(l_l) - u(t_l)| \rightarrow \min, \quad \sum_{t=1}^L \zeta_{lt} = \eta^1_l, \quad (l = \overline{1, L}), \quad \sum_{t=1}^L \zeta_{lt} = \eta^2_l, \quad (t = \overline{1, L}),$$

where $u(l_l), u(t_l)$ are arbitrary functions that retain their order along a discrete scale $\overline{1, L}$.

Fuzzy relation $\alpha_{\eta^1 \sim \eta^2}$ makes it possible to study such preference situations as:

- strict preference: $\alpha_{\eta^1 \eta^2} = 1, \alpha_{\eta^2 \eta^1} = \alpha_{\eta^1 \sim \eta^2} = 0$;
- indifference: $\alpha_{\eta^1 \sim \eta^2} = 1, \alpha_{\eta^1 \eta^2} = \alpha_{\eta^2 \eta^1} = 0$;
- large preference: $\alpha_{\eta^1 \eta^2} + \alpha_{\eta^1 \sim \eta^2} = 1; \alpha_{\eta^2 \eta^1} = 0$;
- incomparability: $\alpha_{\eta^1 \eta^2} \neq 0, \alpha_{\eta^2 \eta^1} \neq 0$.

The first two are common situations of full comparability. We are interested in the third situation. We shall proceed to identify the dominating option starting from iteration $k + (\varkappa - 1)$, the constraint being that for $(k + \varkappa)$ iteration the $(k + \varkappa)$ distribution results in the following relationship:

$$\alpha_{\eta^1 \eta^2} + \alpha_{\eta^1 \sim \eta^2} \rightarrow 1; \alpha_{\eta^2 \eta^1} \rightarrow 0.$$

Therefore, identifying the dominating option of a complex system follows the structural flowchart presented (fig. 3). It combines computational procedures to define the preference vector and the procedures of rational selection.

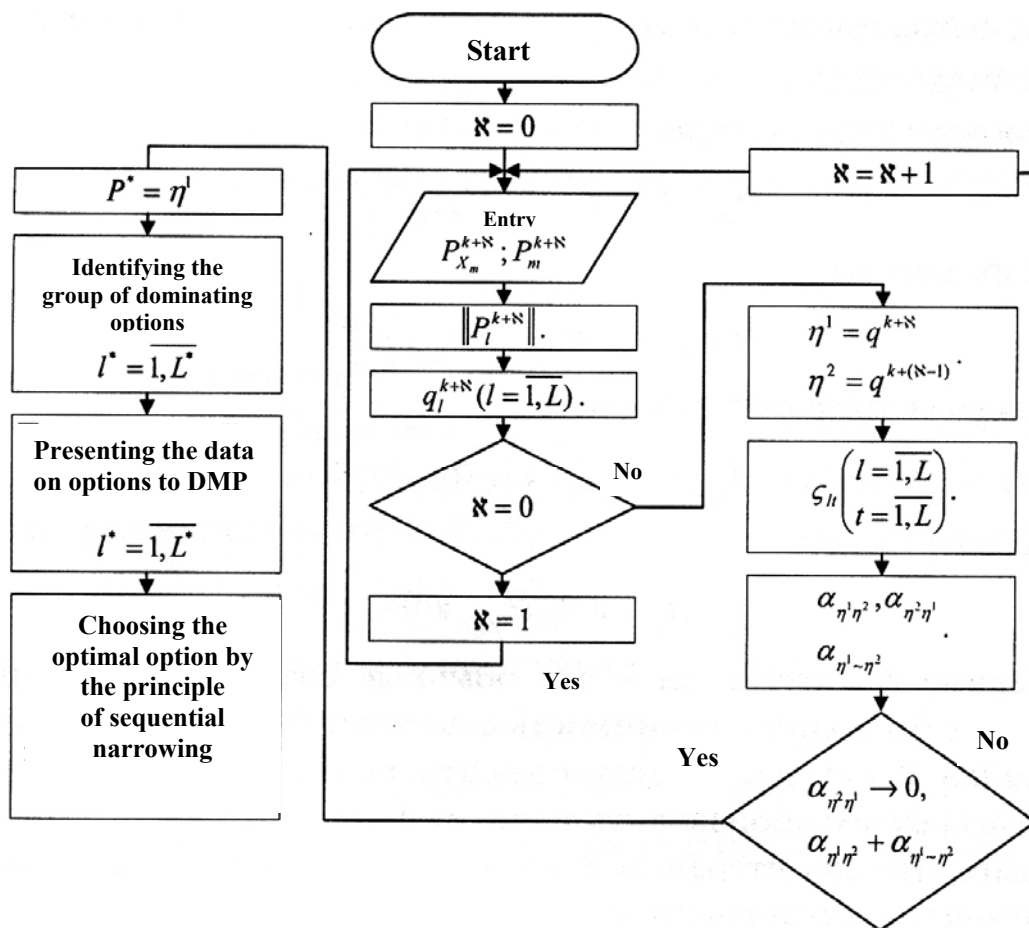

Figure 3. Structural flowchart of identifying the dominating option for a complex system

Conclusion

Development of a numeracy of dominant managerial decisions is possible on the basis of application of basic procedures of variation modeling and building of multialternative optimization models. At that an identification of the dominant option of a complex system is performed on the basis of the developed scheme, that combines procedures for determination of the preference vector and the rational choice procedures.

References

- [1] KORN, G., KORN, T. 1984. *Mathematical Handbook for Scientists and Engineers*. Nauka, 1984, 831 p.
- [2] LVOVICH, Y., E. 2006. *Multialternative optimization: Theory and Applications*. Voronezh: «Quart» Publishing House, 2006, 415 p.
- [3] CHOPOROV, O., N. 2008. Metody analysis of the significance of indicators in the classification and predictive modeling. In: *Bulletin of Voronezh State Technical University*. 2008, vol. 4, no. 9, p. 92-94.
- [4] MOSKALCHUK, Yu., I., NAUMOVA, E., G., KISELEVA, E., V. 2013. Problems of optimization of innovation processes in organizations. In: *Simulation, optimization and information technology*. 2013, no. 2, p. 10.
- [5] SCHINDLER, F. 2015. Algorithmization of decision-making in management of objects with inhomogeneous characteristics. In: *Information technology applications*. 2015, no. 1, p. 13-22.
- [6] RUŽICKÝ, E. 2015. Formalization of user interaction with virtual expert resource of knowledge type via ontological modeling. In: *Information technology applications*. 2015, no. 1, p. 33-43.
- [7] ŠPERKA, M. 2015. Special aspects and principles of identification of objects with inhomogeneous characteristics. In: *Information technology applications*. 2015, no. 1, p. 3-12.
- [8] LVOVICH, I., LVOVICH Y., CHOPOROV, O. 2015. Building of semi-quantile regression models. In: *Information technology applications*. 2015, no. 1, p. 91-110.

Prof. Igor Lvovich, D. Sc.

Pan-European University, Bratislava, Slovakia
office@vivt.ru

Ing. Juraj Štefanovič, PhD.

Pan-European University, Bratislava, Slovakia
juraj.stefanovic@paneurouni.com



Modeling of multi-agent virtual expert competition for the use of expert virtual resource

Yakov Lvovich, Eugen Ružický

Abstract:

One of the current areas of research in the field of corporate systems management is the use of expert and virtual resource (EVR), intended for intellectualization of decision-making support in cases where knowledge corporate environment is poorly structured and it has obscure connections and a multi-level subordination hierarchy. The main components of EVR are real and virtual experts, one of the variations of which is the multi-agent virtual expert (MAVE). In this case, interaction of agents with expert and virtual resource is carried out in a challenge-response mode, and on a certain number of requests, the competition for the use of expert and virtual resource arises. To simulate the competition for resources, an approach based on the use of standard integration logistic mapping, generalized in case of the two interacting MAVE competing for the use of expert and virtual resource, is introduced. The results of numerical calculations confirmed the proposed model effectiveness. It is proved that the cases of stable, non-zero system solutions, i.e. Quantity stabilization of both MAVES, have practical importance.

Key words:

Modeling, numerical methods, expert and virtual resource, multi-agent virtual expert, corporate information system.

ACM Computing Classification System:

User models, User studies, Usability testing, Heuristic evaluations, Walkthrough evaluations, Laboratory experiments, Field studies.

Introduction

When making rational managerial decisions in modern corporate structure, the accumulated intellectual resource and the corporate intellectual capital play an important role. Developing the intellectual resource in modern corporate structures occurs in a common information environment formed by networks of information users within the scope of corporate information systems (CIS) [1]. When considering the intellectual resource from the standpoint of its development in the corporate information environment one needs to treat separately expert and virtual components in the structure of intellectual capital and multi-alternative presentation of its elements in the course of managerial decision making [2].

1. The concept of expert and virtual resource

By ‘decision making’ we mean a three-stage procedure that includes analyzing the initial information, preparing to make decision and selecting a decision generated in the course of interaction between the expert (experts) and a computer system. At that we shall call the combination of expert and computer resources ‘the virtual expert resource for decision making’ and treat it as a component optimizing the management of corporate social (economic) system [3-6].

Provision of expert and virtual resource of knowledge and procedure type, is proposed. Knowledge expert and virtual resource provides intelligent decision making support.

Virtual expert resource of procedural type is meant to intellectualize support for managerial decision making in cases when the corporate knowledge environment is weakly structured, features fuzzy links and a multi-level subordination hierarchy.

The basic components of virtual expert resource are real and virtual experts, the basic principles of their interaction proposed in studies [7].

In their turn, virtual experts may be divided into the following types according to the functions they execute during decision making: imitational prognostic virtual expert (IPVE); multi-alternative virtual expert (MVE); multi-agent virtual expert (MAVE).

2. Characteristics of the multi-agent expert and virtual resource

Let us expand on the description of multi-agent virtual resource (MAVR) as the issues related to IPVE and MVE were covered in sufficient detail in a number of published works [3-6].

The classical techniques for studying competition are the theory of utility and the game theory. In particular, they yield the well-known models and conditions of optimality, expressed as the equilibrium principle. Managing hierarchic structures in organizational economic systems is modeled in the theory of active systems [8, 9].

The basic weakness of the standard model in the theory of active systems is its static character. In contrast to theoretical game models, decisions in multi-agent systems are taken sequentially, which helps the agents to obtain missing information needed to take decisions. Agents interact with virtual expert resource in the question-answer mode as shown (fig. 1).

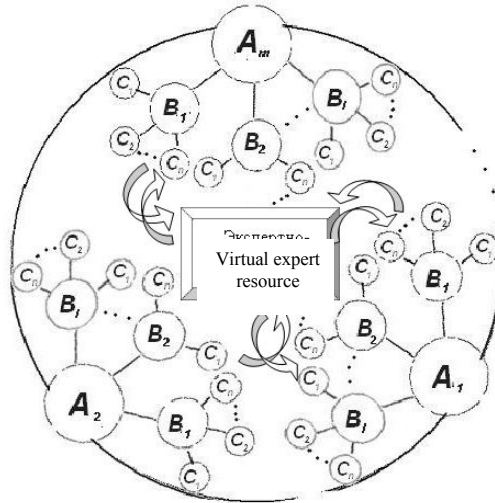

Figure 1. Interaction of multi-agent CIS with virtual expert resource

Let W be the current problem that one of MAVE agents is working on. The agent breaks the problem into a sequence of atomic works w_1, w_2, \dots, w_n and starts executing them. At each step $i = \overline{1, n}$ the possibility is checked to do the work independently on the basis of available resources. As soon as the agent faces the problem of lack of data in the knowledge base of MAVE, and enquiry is formed, addressed to the virtual expert resource of the corporate system.

Having gained the lacking information, the agent proceeds to execute the works all the way to w_n . The algorithm of that execution for a single agent interacting with the virtual expert resource is shown (fig. 2).

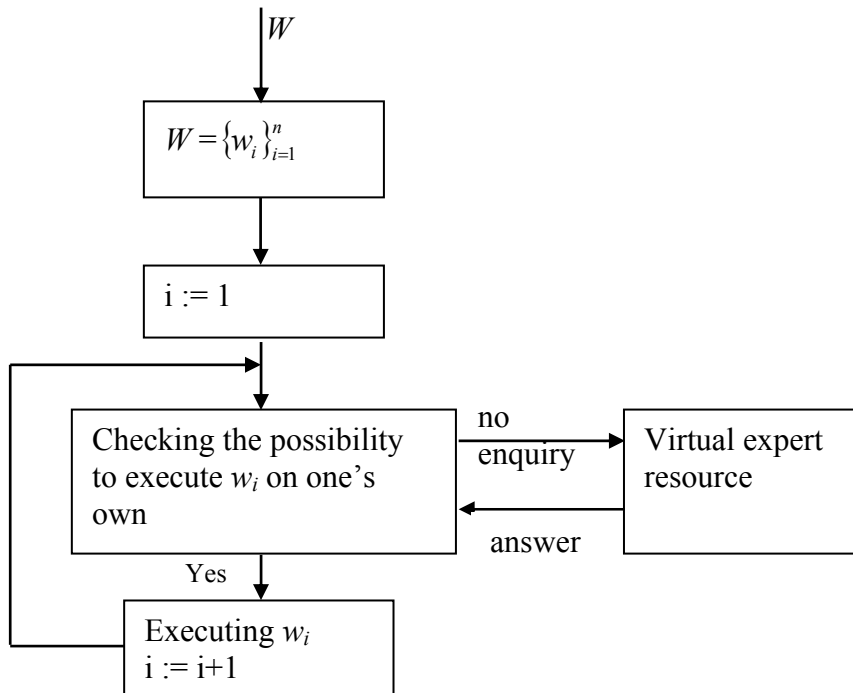

Figure 2. Algorithm of work execution with the help of virtual expert resource

Apparently, with a certain number of enquiries coming from agents of various MAVEs circulating in the common corporate network, there develops a competition for using the virtual expert resource. The agent receives no answer to his/her enquiry from the virtual expert resource within the given timeout in two cases:

- a) the enquiry is formulated wrongly;
- b) the virtual expert resource is overloaded with enquiries from agents of different MAVEs, which means exceeding the acceptable number of agents in the network.

Both cases mean violation of MAVE self-organization, and such an agent is blocked, i.e. a mechanism is set off to stabilize the number of agents in the corporate network. Therefore managing the number of agents is an important task in corporate systems built on using the virtual expert resource of corporate intellectual capital.

3. Modeling of competition for resources on the basis of difference equations

Consider some aspects of modeling the competition for resources using difference equations. The proposed approach was studied assuming the existence of a sustainable equilibrium position and optimizing the management of distribution resource [10].

Currently the standard model for describing discrete dynamics is the so-called logistic map

$$y_{n+1} = 1 - \lambda y_n^2,$$

equivalent to the Verhulst-Pearl model [13]. Indeed, a substitution $x = \frac{y + 1/2}{\alpha/4 + 1/2}$ makes it possible to proceed from the Verhulst-Pearl model

$$x_{n+1} = \alpha x_n (1 - x_n),$$

to the logistic map with its coefficient $\lambda = \alpha(\alpha/4 - 1/2)$.

Extending the model to the case of two interacting MAVEs that compete for the use of virtual expert resource, we consider the system of iteration equations

$$\begin{cases} y_{n+1} = \alpha x_n (1 - x_n) \\ x_{n+1} = \beta y_{n+1} (1 - y_{n+1}) \end{cases} \quad (1)$$

Here x_n is the number of agents of one MAVE, y_n is that of the other MAVE during the n -th cycle of using the virtual expert resource. Let the relative number of agents y_{n+1} during $(n+1)$ -st cycle depend on the number of agents x_n during n -th cycle ($0 \leq x_n, y_n \leq 1$). In its turn, x_{n+1} depends on y_{n+1} . The parabolas in the right-hand part of each equation have their maximums equal to $\alpha/4$ and $\beta/4$ respectively, at point $1/2$. Due to normalization of agent population, the controlling parameters meet inequalities $0 \leq \alpha, \beta \leq 4$. Since the numbers of agents in both MAVEs are interdependent, their interaction may be considered antagonistic.

Monograph [7] studied the population dynamics of competing species. However the general theory, as well as its particular cases relate to equations of different type $x_n = x_n f(x_n, y_n)$, while the function $x f(x, 0)$, related to the “resources” has to increase monotonously. Typical scenarios of transition to chaos via a cascade of period doublings in different nonlinear systems are presented in studies [7, 10, 11].

However, systems considered in those studies contain identical variables in both parts of their equations and are different in principle from the newly proposed system.

Despite its simple form, it is probably the particular reason why the very first study historically [2] made it possible to present the qualitative scenario of evolution of the set of system solutions. Study [2] used numerical techniques to confirm the hypothetical existence of various cyclic solutions for system (1) and the emergence of “chaos”. Calculations were made using a SW application to retrieve numerically the trajectories of system solutions. These were tested continuously for uniqueness at prescribed accuracy and for emergence of cycles of varying length and chaos. The approximate resulting topography of various zones is shown (fig. 3).

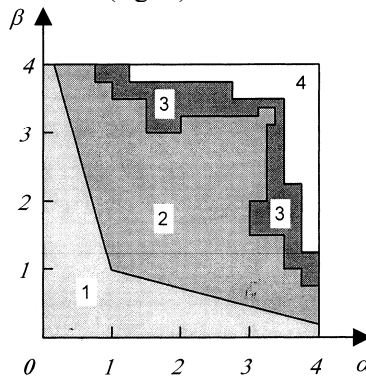

Figure 3. Results of numerical modeling of the system its parameters $0 \leq \alpha, \beta \leq 4$ varied

Area 1 contains solutions for insufficient resource so that both MAVEs degenerate; in area 2 the number of agents in both MAVEs stabilizes; in area 3 a sustainable cycle S^2 emerges; in area 4 cycles of periods 3 and more appear and an uncertainty developing into a chaos follows. Exact boundaries of the areas remain indefinite.

Studies [3-7] defined the boundaries of these areas for the diagonal case ($\alpha = \beta$) and obtained a new graphic presentation of the positions of immobile solutions (“the solutions ellipse”). It was found that the diagonal case yields the well-known Feigenbaum diagram (the Feigenbaum tree), except biased by a single iteration (fig. 4).

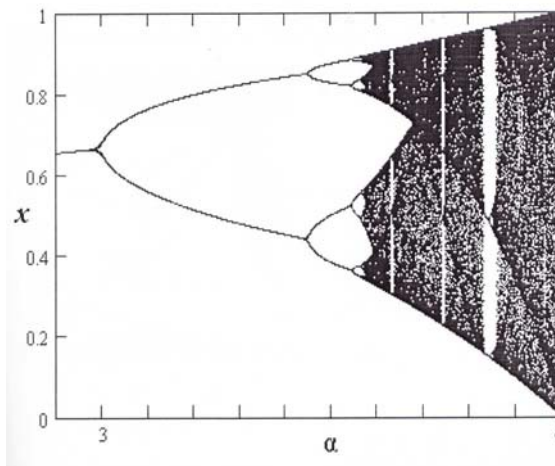

Figure 4. Bifurcation tree for a two-parameter model, $\alpha = \beta$

The most interesting phenomena difficult to study occur in zones defined by their controlling parameters $\alpha, \beta \in (3, 4)$. Below we show the diagrams of the respective solution trajectories.

Figure 5 has one stable point in the vicinity of 1.

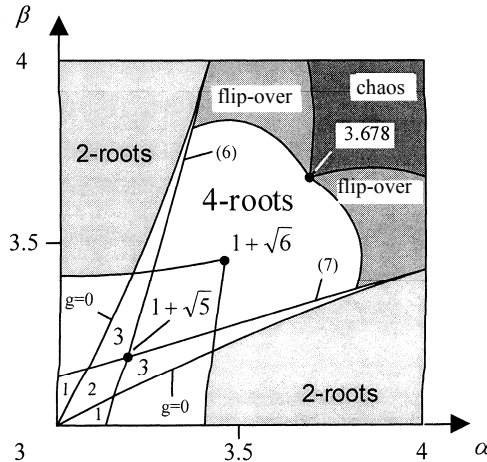

Figure 5. Areas structure for $3 < \alpha < 4, 3 < \beta < 4$

Curve $g = 0$ corresponds to those values (α, β) , for which the system has 3 roots. Essentially, the third root is the touching point for the curves described by equations in the system:

$$\begin{cases} y = \alpha x(1-x) \\ x = \beta y(1-y) \end{cases} \quad (2)$$

In area 2 the system has 4 different roots, the two central of them being unstable and the other two stable (fig. 6).

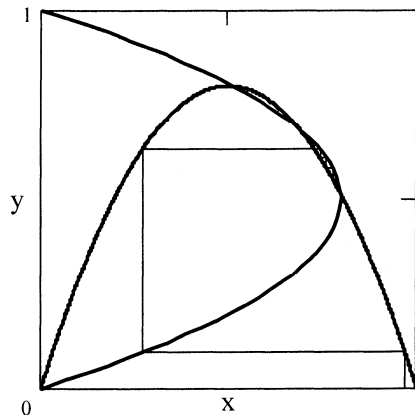

Figure 6. System evolution for $\alpha = \beta = 1 + \sqrt{5}$

That situation means that the number of both MAVEs (the number of enquiries) stabilizes with time and MAVEs stop competing for the virtual expert resource.

Area 3 (fig. 5) corresponds to one function from the equation of system (2) crossing the maximum of another equation of that system and a periodic cycle forming. In our case it means that the number of agents in both MAVEs will keep changing with a certain periodicity. In dependence of the initial conditions in the 4-root area attractors may emerge around either of the two crossing points off both sides of the diagonal, except for

the zones of flip-over (fig. 7). This case is characterized by a pair of alternatives in the numbering of the two competing MAVEs.

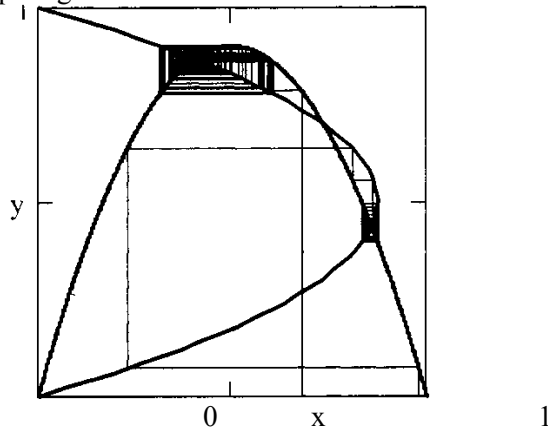

Figure 7. System evolution for $\alpha = 3.6, \beta = 3.5$

Most complex phenomena occur for when parameters α and β yield such wide attractors that their iteration cycles start flipping over from the area of one attractor to the other (fig. 8).

Let us consider the conditions for the occurrence of that phenomenon in more detail. Apparently, the cycle width is limited by functions' maximums. Let there be two cycles passing through the maximums of functions in the right-hand part of first and second equations of system (2) (fig. 7 and fig. 8).

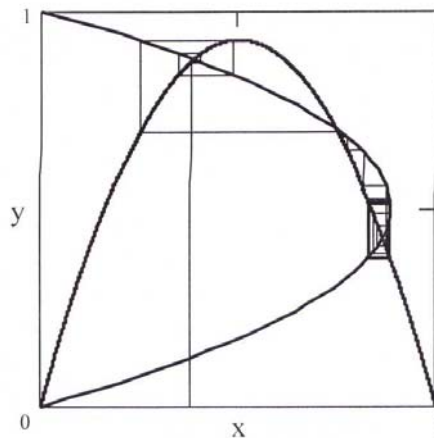

Figure 8. System evolution for $\alpha = 3.7, \beta = 3.55$

The initial evolution of one cycle goes through the states $0 \rightarrow 1 \rightarrow 2 \rightarrow 3$ and the evolution of the other through the states $0' \rightarrow 1' \rightarrow 2' \rightarrow 3'$ (fig. 9).

Apparently, the key role is played by point "A" where the graphs intersect. In case the attractor appears wider than the elevation of point "0" (or "0'") above point "A", the iteration cycle $0 \rightarrow 1 \rightarrow 2 \rightarrow 3$ will fail to reach its attractor and will cross to the area of the other attractor instead.

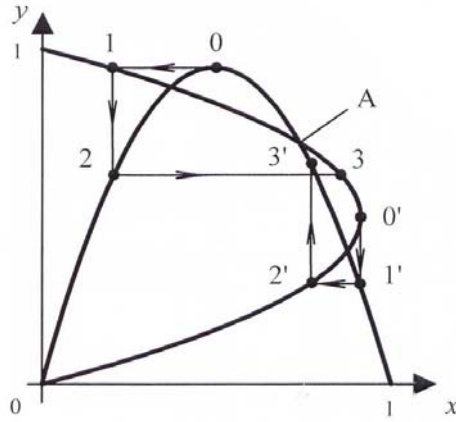

Figure 9. Cycle to cycle flip-over

We obtain an exact expression for the boundaries of that phenomenon. Consider the evolution of cycle $0 \rightarrow 1 \rightarrow 2 \rightarrow 3$. We have

$$\begin{aligned}
 x_0 &= \frac{1}{2}, \\
 y_0 &= \frac{\alpha}{4}, \\
 x_1 &= \frac{\alpha\beta}{4} \left(1 - \frac{\alpha}{4}\right), \\
 y_2 &= \frac{\alpha^2\beta}{4} \left(1 - \frac{1}{4}\right) \left[1 - \frac{\alpha\beta}{4} \left(1 - \frac{\alpha}{4}\right)\right], \\
 x_3 &= \frac{\alpha^2\beta^2}{4} \left(1 - \frac{\alpha}{4}\right) \left[1 - \frac{\alpha\beta}{4} \left(1 - \frac{\alpha}{4}\right)\right] \left\{1 - \frac{\alpha^2\beta}{4} \left(1 - \frac{\alpha}{4}\right) \left[1 - \frac{\alpha\beta}{4} \left(1 - \frac{\alpha}{4}\right)\right]\right\},
 \end{aligned}$$

While cycle $0' \rightarrow 1' \rightarrow 2' \rightarrow 3'$ yields:

$$\begin{aligned}
 y_{0'} &= \frac{1}{2}, \\
 x_{0'} &= \frac{\beta}{4}, \\
 y_{1'} &= \frac{\alpha\beta}{4} \left(1 - \frac{\beta}{4}\right), \\
 x_{2'} &= \frac{\alpha\beta^2}{4} \left(1 - \frac{\beta}{4}\right) \left[1 - \frac{\alpha\beta}{4} \left(1 - \frac{\beta}{4}\right)\right].
 \end{aligned}$$

Equating $x_{2'} = x_3$ we get an equation for the curve where attractors start to overlap. Using the problem symmetry one may assume $x_3 = 1 - x_1$ and simplify the expression: $x_{2'} = 1 - x_1$ or

$$\frac{\alpha\beta^2}{4} \left(1 - \frac{\beta}{4}\right) \left[1 - \frac{\alpha\beta}{4} \left(1 - \frac{\beta}{4}\right)\right] = 1 - \frac{\alpha\beta}{4} \left(1 - \frac{\alpha}{4}\right) \tag{3}$$

Actually we have proved the following statement describing the fine structure of the 4-root zone: **The chaos area is limited by the two branches of equation (3).**

As its consequence this statement entails the well-know constant valid for the classical one-dimensional case that separates cycle area from that of chaos (the area of unpredictable behavior of solutions in a sense). For $\alpha=\beta$ that expression has the form:

$$\frac{\alpha^2}{4} \left(1 - \frac{\alpha}{4} \right) - 1 = 0$$

with its real solution:

$$\alpha = \frac{2}{3} \left(\sqrt{19 + 3\sqrt{33}} + \frac{4}{\sqrt{19 + 3\sqrt{33}}} + 1 \right) \approx 3.678$$

Therefore, a state commonly called chaos develops in the range of $\alpha, \beta \geq 3.678$ (fig. 10).

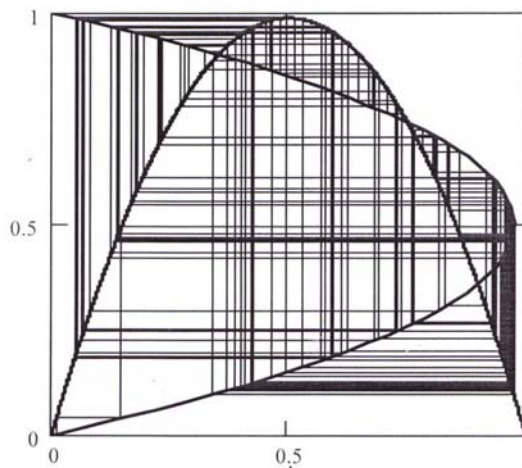

Figure 10. System evolution for $\alpha = 3.95, \beta = 3.9$

The last case means that self-organized MAVEs replicate their agents at a large frequency resulting in failures when addressing the virtual expert resource.

Of practical significance is the case of stable system solutions different from zero, i.e. of stabilization in the numbers of both MAVEs.

Optimizing the number of agents for more than two MAVEs is reduced to the problem of finding such controlling parameters α and β that stabilize their numbers for each pair of MAVEs.

Conclusion

The application of a modeling procedures package that allow to carry out an adequate transformation of the intellectual capital components with a focus on multi-agent experts functioning in expert and virtual environment of managerial decision-making is reasonable to use in expert intelligent systems building to provide effective teamwork of real and virtual experts when making optimal decisions. The process of interaction of agents with the expert and virtual resource on a certain number of requests results into the competition for resources, which can be simulated by using the approach proposed in the

article. The results of numerical calculations have confirmed the effectiveness of the developed model, which suggests the possibility of its practical use.

References

- [1] MOSKALCHUK, Y.I., NAUMOVA, E.G., KISELEVA, E.V. 2013. Problems of optimization of innovation processes in organizations In *Simulation, optimization and information technology*. 2013, no. 2. p. 10.
- [2] CHOPOROV, O.N., CHUPEEV, A.N., BREGEDA, S.Y. 2008. Analysis Methods of the significance of indicators in the classification and predictive modeling In *Bulletin of Voronezh State Technical University*. 2008. vol. 4, no. 9, p. 92-94.
- [3] SCHINDLER, F., 2015. Algorithmization of decision-making in management of objects with inhomogeneous characteristics In *Information technology applications*, 2015, no. 1, p.13-22.
- [4] RUŽICKÝ, E., 2015. Formalization of user interaction with virtual expert resource of knowledge type via ontological modelling In *Information technology applications*, 2015, no. 1, p.33-43.
- [5] ŠPERKA, M. 2015. Special aspects and principles of identification of objects with inhomogeneous characteristics In *Information technology applications*, 2015, no. 1, p.3-12.
- [6] LVOVICH, I., LVOVICH, Y., CHOPOROV, O. 2015. Building of semi-quantile regression models In *Information technology applications*, 2015, no. 1, c.91-110.
- [7] LVOVICH. Y.E. 2006. Multialternative Optimization: Theory and Applications Voronezh, 2006 Publisher "Quart", 415 p.
- [8] PREOBRAZHENSKY, Y.P., PANEVIN, R.Y. 2010. Transfiguration YP The wording and classification of problems of optimal control of production facilities In *Bulletin of Voronezh State Technical University*. 2010. vol. 6, no. 5. p. 99-102.
- [9] GUSKOV, L.B., GUSKOVA, L.B. 2012. On the construction of the automated work place manager. In *Successes of modern science*. 2012, no. 6. p. 106.
- [10] RODIONOVA, K.Y. 2012. Globalization of the world economy: the nature and contradictions In *Herald of the Voronezh Institute of High Technologies*. 2012, no. 9. p. 185-186.
- [11] SHISHKINA, Y.M., BOLUCHEVSKAYA, O.A. 2011. Public administration In *Recent studies of social problems*. 2011. vol. 6, no. 2. p. 241-242.

Prof. Yakov Lvovich, D. Sc.

the honored scientist of the Russian Academy of Natural Sciences
President of Voronezh Institute of High Technologies
office@vivot.ru

Doc. RNDr. Eugen Ruzicky, CSc.

Pan-European University, Bratislava, Slovakia
eugen.ruzicky@paneurouni.com



Algorithmization of interaction of components of expert virtual resource of procedural type in managerial decision-making optimization

Yakov Lvovich, Oleg Choporov, Andrew Preobrazhensky

Abstract:

For intellectualization of managerial decision making support in corporate systems it is recommended to use expert and virtual resource (EVR), which is a combination of expert and computer resources. In the case when knowledge corporate environment is poorly structured and it has obscure connections and a multi-level subordination hierarchy, the EVR of procedural type intended for intellectual support of decision-making, is used.

Considering the existing diversity of EVR of procedural type, there is a necessity to develop algorithms for interaction of their components in managerial decision making in various modes.

Algorithmization of a virtual mode of interaction is related to the sequential use of all the three types of virtual experts, thus the basic procedure of multialternative optimization used by multialternative virtual expert (MVE) prevails.

The principal task of developing the algorithm of dual mode interaction between the virtual and real experts in the environment of managerial decision making consists in development of a matrix game.

Algorithmization of a collective mode of interaction of real and virtual experts is based on a man-machine procedure which provides a dialogue with real experts on the basis of automatically offered questions, with further formalization of expert answers. An iterative principle of building of this procedure by means of immersion of question-answer process with a team of real experts in randomized environment, is proposed. A Team mode with a dominating expert is based on agreeing the assessments of priority of alternative optional managerial decisions by that expert with assessments by a team of peer experts. The developed algorithms can be integrated into the single environment of the managerial decision making subsystem and used as a means of intellectual support.

Keywords:

Optimization, simulation, managerial decision making, choice of dominant options, expert and virtual resource.

ACM Computing Classification System:

Parallel programming languages, Optimization algorithms, Exact arithmetic algorithms, Hybrid symbolic-numeric methods.

► Introduction

The optimal managerial decision making is based on systemization, analysis of large amounts of accumulated information, use of methods of forecasting and mathematical modeling, engagement of leading experts in evaluation. As can be seen from the above, this process requires attraction of extensive resources both human (expert), and computer, and their close interaction. The set of expert and computer resources in a series of works is called expert and virtual resource (EVR) of decision making. [1-4]. It is proposed to identify the two types of EVR which are procedural and knowledgable. The first virtual expert resource provides intellectual support for decision choosing, the second supports all three stages of decision making.

Virtual expert resource of procedural type is meant to intellectualize support for managerial decision making in cases when the corporate knowledge environment is weakly structured, features fuzzy links and a multi-level subordination hierarchy.

The basic components of virtual expert resource are real and virtual experts, the basic principles of their interaction proposed in studies [5, 6].

Either an individual real expert (IRE) or a team of real experts (TRE) is brought in to make decision.

In their turn, virtual experts may be divided into the following types according to the functions they execute during decision making:

- imitational prognostic virtual expert (IPVE);
- multi-alternative virtual expert (MVE);
- multi-agent virtual expert (MAVE) [1-4, 7-9].

To formalize the interaction of components of the expert and virtual resource of a procedural type in making optimal managerial decisions, the problem of development of appropriate algorithms arises.

► 1. Virtual interaction mode

Algorithmizing the virtual mode of interaction involves sequential use of three types of virtual experts: IPVE, MVE and MAVE. The basic procedure is multi-alternative optimization used by MVE [5, 6]. It calculates variations of the criteria F and functions and constraints φ while the alternative variables change

$$z_m = \begin{cases} 1, \\ 0, \end{cases} m = \overline{1..M}.$$

The variation of a given factor F over variable z_m at k -th iteration is given by:

$$\Delta_m^k F = F(\bar{z}^k / z_m = 0) - F(\bar{z}^k, z_m = 1),$$

where $\bar{z}^k = (z_1, \dots, z_\nu, \dots, z_M)$ ($\nu = \overline{1, M}, \nu \neq m$) is the vector of random realizations of alternative variables. To organize the process of multi-alternative optimization and formation of sets of dominating options W_δ , three variations are used, i.e. 6 calculations of the factor are made.

Each calculation includes searching for the value of parameter f_m corresponding to the alternative variable $z_m = 1$. Next one has to retrieve the dependence of factor F on f_m : $F = F(f_m)$. Calculations have to be carried out for indicators I_1 corresponding to the criteria, and I_2 corresponding to constraints. Therefore, the total number of search and retrieval procedures for each k -th iteration is

$$\pi^k = 6[\pi_n(z_m = 1, I_1 + I_2) + \pi_\epsilon(z_m = 1, I_1 + I_2)],$$

where the first element in the sum gives the number of search procedures of the first type depending on the number of alternative variables and the total number of criteria and constraints, and the second gives the number of retrieval procedures that depends also on the number of alternative variables and the total number of factors.

As for retrieval procedures, IPVE is used, and addressing the corporate intellectual capital is again needed to search for retrospective quantitative information and update expert data, as described in modeling techniques presented in Section 3.1. Note that one needs π_n^ϵ search procedures of second type to retrieve $F = F(f_m) - \pi_n^\epsilon$.

To implement search procedures of first type one uses the multi-agent virtual expert of first type with x agents, and that of second type with y agents. To forecast the degree of competition between the two types of MAVEs for the virtual expert resource, we use the system of iteration equations from Section 3.3:

$$\begin{cases} y^{k+1} = \alpha x^k (1 - x^k) \\ x^{k+1} = \beta y^k (1 - y^{k+1}) \end{cases}$$

To assess the controlling parameters α and β we refer to the first two iterations finding

$$\pi_n^{(1)}, \pi_n^{(2)}, \pi_n^{\epsilon(1)}, \pi_n^{\epsilon(2)} \text{ for them and then retrieving } x^1, x^2, y^1, y^2.$$

$$\alpha = \frac{y^2}{x^1(1 - x^1)},$$

$$\beta = \frac{x^2}{y^1(1 - y^2)}.$$

With α and β known we model numerically the system of iteration equations for $k > 2$. In case we reach area 2, the number of agents in MAVEs of two types stabilizes, and it is feasible to proceed to the virtual interaction mode. Otherwise one needs to substitute one of the MAVEs. Selecting the two types of MAVEs goes on until we reach area 2 in the result of numerical modeling.

This sequence of operations constitutes selection of the more effective agent for search and assembly of information (SASA). Upon addressing SASA and defining the two types of MAVE, one needs to assess the number of iterations (k^0) needed to form the set of dominating options W_δ .

Functions belonging to the conditions of information balance for multi-alternative

optimization procedures [5] are found from experimental studies: the current random amount of information in averaged message

$$\tilde{\varphi}_1(k) = \tilde{a}_{01} - \tilde{a}_{11}(1 - l^{\tilde{a}_{21}k});$$

and the current random average of channel throughput capacity

$$\tilde{\varphi}_2(k) = \tilde{a}_{02} - \tilde{a}_{12}(1 - l^{\tilde{a}_{22}k})$$

It is assumed that during multi-alternative optimization the value of variable z_m will be equal to 1 within the scope of probabilities change, $p_{zm} (1 - \varepsilon, 1)$, and to 0 in the $(0, \varepsilon)$ area. Then, following [5]:

$$\tilde{\varphi}_1(k) - \tilde{\varphi}_2(k) = -\varepsilon(k) \lg \varepsilon(k) - (1 - \varepsilon(k)) \lg(1 - \varepsilon(k)) + \varepsilon^k \lg(2^M - 1) = Q(k).$$

We set the value of function $\varphi_1(k)$ starting from the desired number of dominating optional alternative managerial decisions in the set $W_\delta - L^*$, define $\varphi_1^0 = \lg L^*$ and set the value of probability $P(\tilde{\varphi}_1(k) \leq \varphi_1^0)$. Since it is known that the expectancy and variance of $\tilde{\varphi}_1(k)$ and $\tilde{\varphi}_2(k)$ depend on the expectancies of parameters (\tilde{a}_0) , (\tilde{a}_1) , (\tilde{a}_2) respectively ($a_{01}, a_{02}, a_{11}, a_{12}, a_{21}, a_{22}$ and variances $D(\tilde{a}_{21})$ and $D(\tilde{a}_{22})$), these values themselves follow the normal distribution law for fixed k . Then one may suggest the following algorithm to define k^0 :

- 1) We find

$$Q^0 = \varepsilon^0 \lg \varepsilon^0 - (1 - \varepsilon^0) \lg(1 - \varepsilon^0) + \varepsilon^0 \lg(2^M - 1)$$

for a prescribed ε^0 .

- 2) For L^* prescribed with respect to φ_1 the probability is

$$P(\tilde{\varphi}_1(k) \leq \varphi_1^0) = P([\tilde{Q}_k - \tilde{\varphi}_2(k)] \leq \varphi_1^0).$$

- 3) With the account of normal distribution of $\tilde{\varphi}_1$ and $\tilde{\varphi}_2$ and the exponential form of retrieved relationship we proceed to the relationship for normalized distribution function Φ [10, 11]:

$$\Phi \left(\frac{\frac{1}{k^0} \ln \left(\frac{\varphi_2^0 - Q^0 - a_{02}^2 + a_{12}^2}{a_{22}^2} \right)}{\frac{1}{D^{\frac{1}{2}}(\tilde{a}_{22})}} \right) = \Phi \left(\frac{\frac{1}{k^0} \ln \left(\frac{\varphi_1^0 - a_{01}^1 + a_{11}^1}{a_{21}^2} \right)}{\frac{1}{D^{\frac{1}{2}}(\tilde{a}_{21})}} \right).$$

- 4) Finally we retrieve k^0 from that relationship.

Upon cutting off the iteration process for $k=k^0$, we follow the procedure outlined in Section 3.2 to form the set W_δ .

The structure of algorithmic procedure used to implement the virtual interaction mode is shown in figure 1.

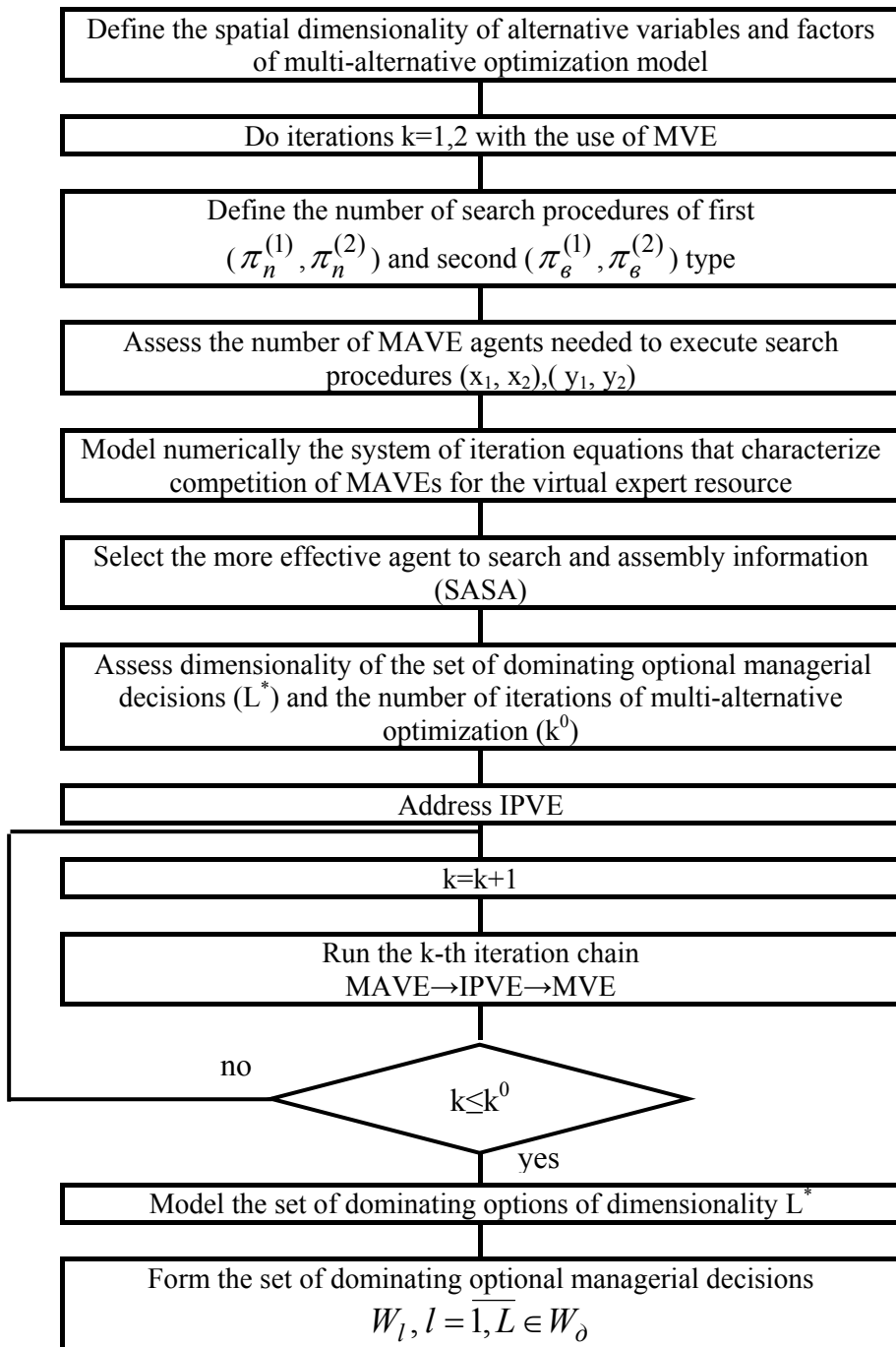

Figure 1. Structural flowchart of algorithmic procedure for the virtual interaction mode

2. Dual interaction mode

The principal task of developing the algorithm of dual mode interaction between the virtual and real experts (Section 2.2) in the environment of managerial decision making consists in forming a matrix game (MG) [11, 12]. The first player (A) is the multi-alternative virtual expert. Following Section 3.2 it forms the set of dominating options $W_l \in W_\partial$, $l = \overline{1, L}$, which present strategies A_l , $l = \overline{1, L}$. The second player (B) assesses these options according to each criterion ψ_i , $i = \overline{1, I}$. It has two strategies: the first (strategy B_1) consists in using MVE for each criterion ψ_i , $i = \overline{1, I}$ followed by definition of probabilities with the procedures of Section 3.2 and selection of l -th option $q_l^{\psi_i}$, $l = \overline{1, L}$. The second strategy (B_2) consists in bringing in a real expert that offers subjective assessments of each option W_l following the criteria ψ_i . As for strategy B_1 , we get probabilistic assessments of $q_l^{\psi_i}$, normalized over the interval $[0, 1]$ immediately. For strategy B_2 it is suggested to use procedures from Section 3.1 to construct the model $\psi_i(x)$, where x is the vector of values of varied parameters, define the values $\psi_{il}(x_l)$ for $l = \overline{1, L}$ and find the values $\delta_l^{\psi_i}$, normalized over the interval $[0, 1]$

$$q_l^{\psi_i} = \frac{\psi_{il} - \min_{l=1, L} \{\psi_{il}\}}{\max_{l=1, L} \{\psi_{il}\} - \min_{l=1, L} \{\psi_{il}\}}$$

where $\max_{l=1, L} \{\psi_{il}\}$, $\min_{l=1, L} \{\psi_{il}\}$ are the maximum and minimum values of criterion ψ_i ,

respectively, calculated following the model over the set of options W_l , $l = \overline{1, L}$. In the result we have a $(2 \times L)$ matrix game. The matrix of such a game $(2 \times L)$ for the criterion ψ_i , $i = \overline{1, I}$ has the form [5]:

$A \backslash B$	B_1	B_2
A_1	$q_1^{\psi_i}$	$\delta_1^{\psi_i}$
:	:	:
A_l	$q_l^{\psi_i}$	$\delta_l^{\psi_i}$
:	:	:
A_L	$q_L^{\psi_i}$	$\delta_L^{\psi_i}$

To find the optimal strategy we use the procedure of reducing the game of the form $(2 \times L)^{W_i}$ to the game $(2 \times 2)^{W_i}$.

	<i>B</i>	<i>B</i> ₁	<i>B</i> ₂
<i>A</i>	<i>W</i> ¹	q^{1W_i}	δ^{1W_i}
<i>A</i>	<i>W</i> ²	q^{2W_i}	δ^{2W_i}

where *W*¹, *W*² are the strategies of first and second players upon reduction to game $(2 \times 2)^{W_i}$.

The optimal probabilities and pure strategies for the (2 x 2) matrix are calculated following the formula [5]:

$$P(W^1) = \frac{\delta^{2W_i} - q^{2W_i}}{(q_1^{W_i} + \delta^{2W_i}) - (\delta^{1W_i} - q^{2W_i})}, \quad P(W^2) = 1 - P(W^1).$$

A mixed strategy that consists of realizing pure strategies *W*¹ and *W*² randomly with probabilities *P*(*W*¹) and *P*(*W*²) is optimal.

To proceed from game $(2 \times L)^{W_i}$ to game $(2 \times 2)^{W_i}$ it is suggested to:

1. Exclude strategies *W*_{*i*} that do not meet constraints imposed by the set of constraining functions φ (Section 2.1) from the matrix $(2 \times L)^{W_i}$.

2. Retain only the dominating strategies in the matrix, i.e. those on which both real and virtual experts express high confidence in their effectiveness.

3. Upon reducing preliminarily the number of pure strategies to *L*₁ < *L* use the dichotomy principle. For that we find a mixed strategy *W*_{1,2}^{W_{*i*}} from $(2 \times 2)^{W_i}$ matrices with strategies of the first player *A*₁=*W*₁, *A*₂=*W*₂

	<i>B</i>	<i>B</i> ₁	<i>B</i> ₂
<i>A</i>	<i>W</i> ₁	$q_1^{W_i}$	$\delta_1^{W_i}$
<i>A</i>	<i>W</i> ₂	$q_2^{W_i}$	$\delta_2^{W_i}$

and calculate assessed strategies of player B for the following probabilities of mixing pure strategies *W*₁ and *W*₂:

$$S_{1,2}^{W_i} = \left| \begin{matrix} p^{W_i}(W_1) \\ p^{W_i}(W_2) \end{matrix} \right|, \quad i = \overline{1, I}$$

The assessment is done as following:

$$\delta_{1,2}^{\Psi_i} = \delta_1^{\Psi_i} p^{\Psi_i}(W_1) + \delta_2^{\Psi_i} p^{\Psi_i}(W_2)$$

Next we find the mixed strategy $W_{1,2,3}^{\Psi_i}$, $i = \overline{1, I}$ from matrices

<i>A</i> \ <i>B</i>	<i>B</i> ₁	<i>B</i> ₂
<i>W</i> _{1,2}	$q_{1,2}^{\Psi_i}$	$\delta_{1,2}^{\Psi_i}$
<i>W</i> ₃	$q_3^{\Psi_i}$	$\delta_3^{\Psi_i}$

and repeat that transition to include strategy W_{L_3} .

In the result we find probabilistic assessments of mixed strategies for the criteria Ψ_i , $i = \overline{1, I}$:

$$S_{L_1-1, L_1}^{\Psi_i} = \left| \begin{matrix} p^{\Psi_i}(W_{1, \dots, L_1-1}) \\ p^{\Psi_i}(W_{L_1}) \end{matrix} \right|, i = \overline{1, I}$$

The structural flowchart of this dichotomy procedure is shown in figure 2.

Probabilities for pure strategies $p^{\Psi_i} W_i$ are used for the final selection. Preferred is the strategy with a maximum probability from among S^{Ψ_i} , $i = \overline{1, I}$. In case it is a

pure strategy, it is accepted as the best pure strategy $W_{MG}^{*\Psi_i}$. If it is a mixed strategy, we compare probabilities belonging to $S_{\Psi_i}^{L-2}$, $i = \overline{1, I}$ and proceed with the process until a pure strategy is finally selected.

Therefore, we have “*I*” best pure strategies for each criterion $W_{MI}^{*\Psi_i}$, $i = \overline{1, I}$. The alternative W_i , corresponding to a pure strategy of the first player that has become the best for the highest number of I ($2 \times L$) Ψ_i matrix games is accepted as the agreed dual decision W_{MI}^* .

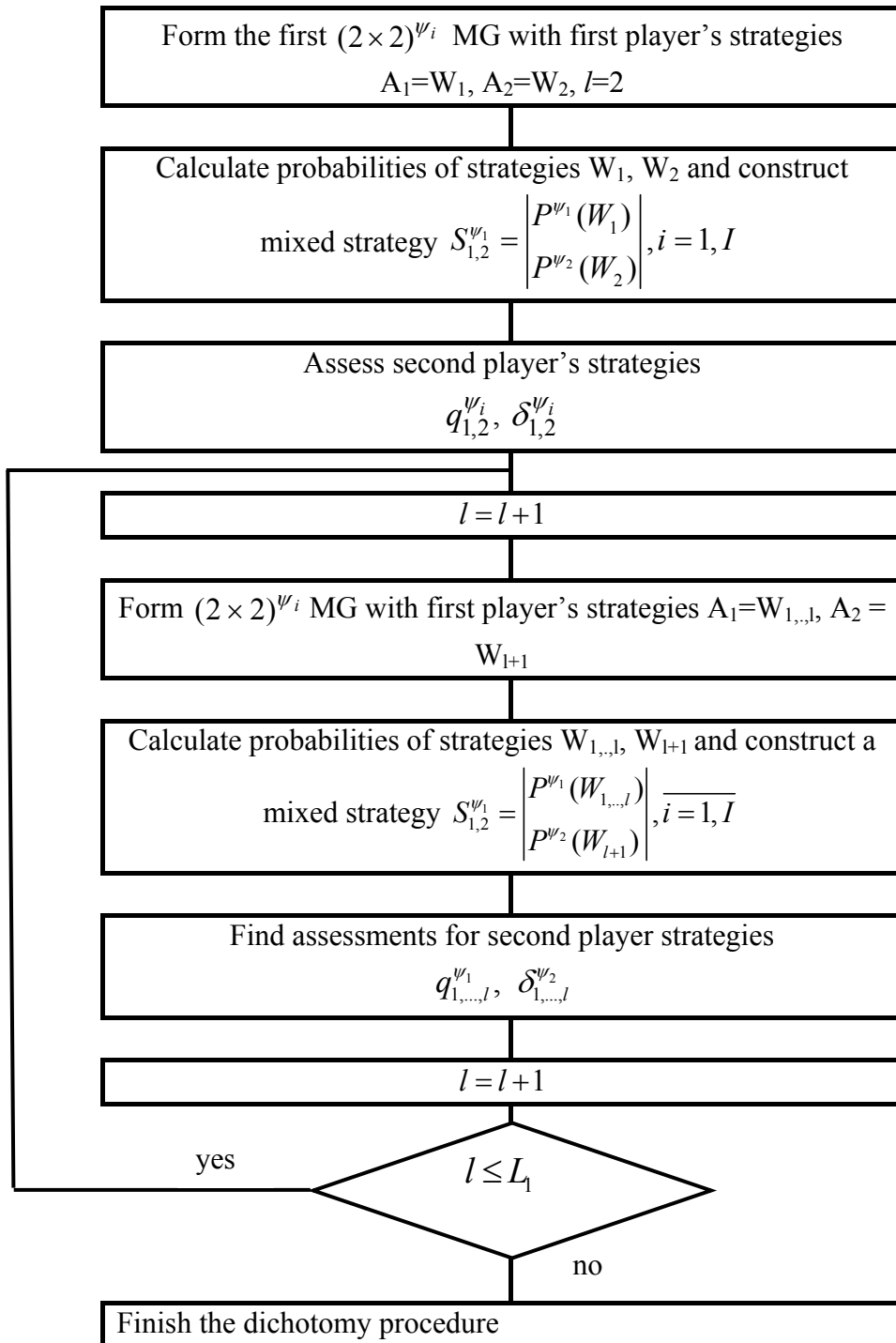

Figure 2. Structural flowchart of dichotomic transformation procedure for MG $(2 \times L)^{w_i}$

Structural flowchart of the algorithm of dual mode interaction between the real and the virtual experts is shown in figure 3.

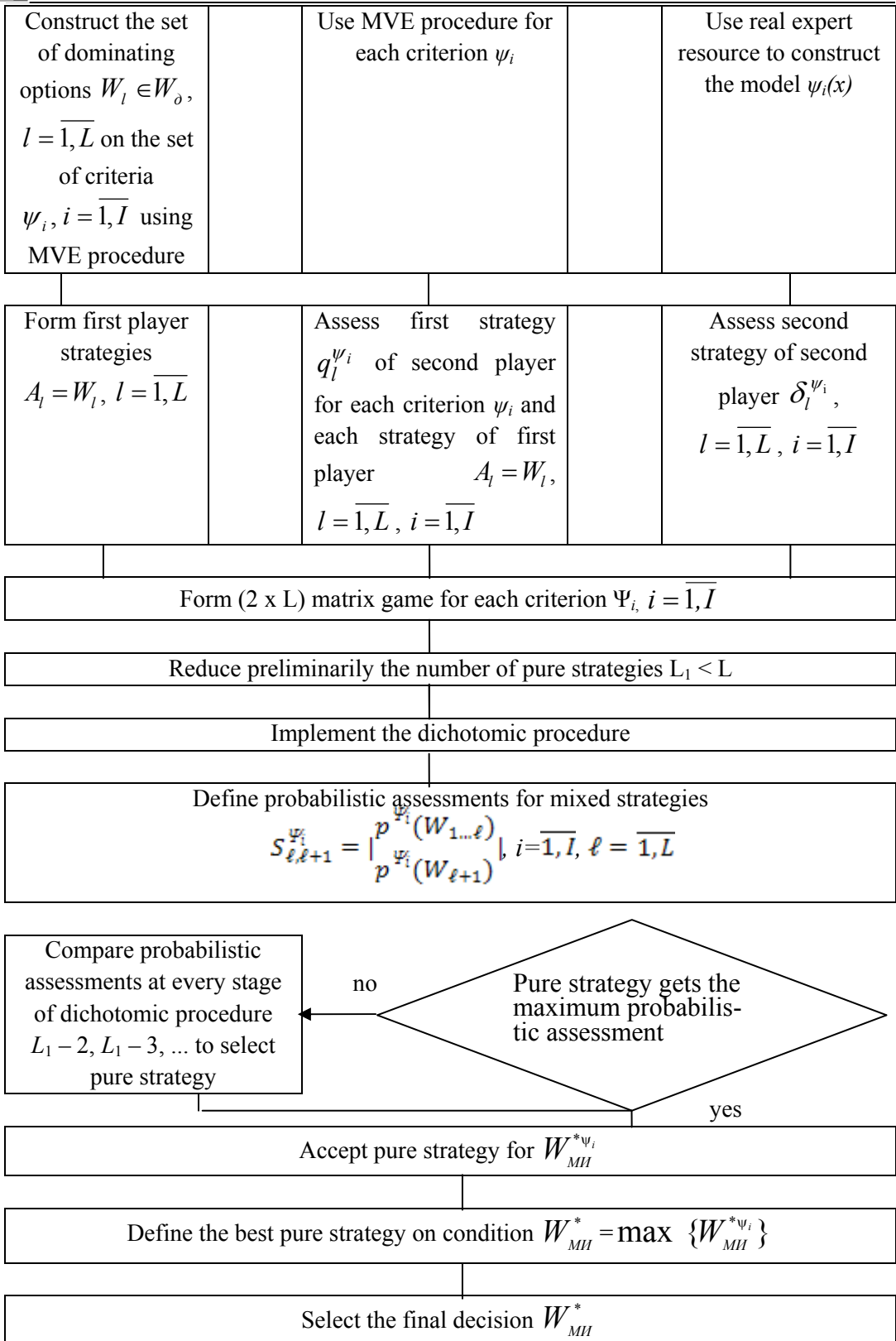

Figure 3. Structural flowchart of the algorithm of dual mode interaction between the virtual and real experts

3. Team interaction of experts of equal rank

Developing an algorithm for team interaction between the real and virtual experts to select optimal (rational) managerial decisions is based on man-machine procedure. It merges the resources of virtual and real experts and supports the dialogue with actual experiments via automatically offered questions, expert answers formalized next [5, 6, 13]. An iterative principle of constructing that procedure is suggested, immersing the question-answer process with the team of real experts into randomized environment. Such an environment provides for possible adaptive step-by-step tuning of distribution of random values that influence the training of experts during interaction. Experts may observe the outcome of decision they have taken on the previous step and adjust their expert valuation as needed, in dependence of answers by real experts and criteria Ψ_i , $i = \overline{1, I}$ assessed by the virtual expert. In case of MVE the set of dominating alternatives W_o is formed in advance.

Assume a group of real experts numbered $d = \overline{1, D}$ assess the alternatives W_l , $l = \overline{1, L}$ according to criteria $\Psi_i^{W_l}$, $i = \overline{1, I}$, their values defined by the virtual expert. To form a randomized environment we introduce the following random variables and distributions:

\tilde{l} is a discrete random variable, its values $\tilde{l} = \overline{1, l}$ having the probabilities p_l , $l = \overline{1, L}$, $\sum_{l=1}^L p_l = 1$ that characterize the level of significance of alternative managerial decisions;

\tilde{i} is a discrete random variable, its values $\tilde{i} = \overline{1, I}$ having the probabilities p_i , $i = \overline{1, I}$, $\sum_{i=1}^I p_i = 1$ that characterize the level of significance of criteria used to assess expert alternative decisions;

\tilde{d} is a discrete random variable, its values $\tilde{d} = \overline{1, D}$, having the probabilities p_d , $d = \overline{1, D}$, $\sum_{d=1}^D p_d = 1$ that characterize the degree of trainability of real experts in the course of the dialogue and receipt of new information on significance of alternative decisions.

The first step in this team procedure is to define the ranks of criteria using a priori ranging as outlined in Section 3.1.

In the result we obtain integer values of rank $r_i \in \overline{1, I}$ that decrease together with significance of criteria for the team of experts. It is suggested to use these values to obtain the initial distributions of discrete random values \tilde{i} and \tilde{d} so that the more significant criterion or better trained expert gains higher probability of being involved in the search in randomized environment:

$$p_i^1 = 1 - \frac{r_i}{\sum_{i=1}^{\overline{I}} r_i}, i = \overline{1, I}$$

$$p_d^1 = \frac{\sum_{i=1}^I (r_i - r_i^d)^2}{\sum_{d=1}^{\overline{D}} \sum_{i=1}^I (r_i - r_i^d)^2}, d = \overline{1, D}$$

where r_i^d is the rank attributed to i -th criterion by d -th expert,

$(r_i - r_i^d)^2$ is the degree of deviation of d -th expert rank from its average value.

Since no information on preferred alternatives W_i is available during the initial stage, a uniform distribution is assumed for the discrete random variable \tilde{l} :

$$p_l^1 = \frac{1}{L}, l = \overline{1, L}.$$

Next we use normalized values of the criteria $\hat{\psi}_i = \frac{\psi_i - \psi_i^{\min}}{\psi_i^{\max} - \psi_i^{\min}}$, where

$\psi_i^{\min}, \psi_i^{\max}$ are the respective minimum and maximum values of i -th criterion on the set of alternatives $W_l, l = \overline{1, L}$.

At each k -th iteration ($k > 1, k = 2, 3, \dots$) the following sequence of steps is taken:

1. Following the distribution $p_d^k, d = \overline{1, D}$ we generate the value of discrete random number $\tilde{d} = d^k$.

2. Following the distribution $p_l^k, l = \overline{1, L}$ we generate the value of discrete random number $\tilde{l} = l^k = j$ and present it to expert d^k to value the alternative W_j .

3. Man-machine procedure is realized as a dialogue with expert number d^k . He/she is asked: "The value of which of the criteria characterized by alternatives W_j , fails to meet it to the worst degree?"

Let the answer be: "Criterion number i^k ".

Next question is: "To what degree should the values of criteria $\Psi_i, i = \overline{1, I}$ characterizing alternative W_j be changed to have a desired improvement?"

That degree is specified by a linguistic variable <should be changed> with its grades of <strongly> <significantly> <somewhat> <a little> <very little> given in [5].

4. The set of criteria numbered i_1^k, \dots, i_s^k is considered, the grade of their linguistic variable being <strongly>. This situation is formalized, first, as sign assessment:

$$\theta_i^k = \begin{cases} 1, & \text{if } i \in i_1^k, \dots, i_S^k \\ -1, & \text{in the opposite case } i = \overline{1, I} \end{cases}$$

and, second, as the average value of membership function μ [58] of the considered linguistic variable:

$$\mu^k = \frac{\sum_{i=i_1^k}^{i_S^k} \mu_i^k}{S},$$

where μ_i^k is the value of membership function for i -th criterion on k -th iteration.

It is suggested to use the function presented in [5] as the membership function.

5. Sets of criteria are considered, the grade of their linguistic variable being <very little>, and the number of such criteria T_j^k is calculated. In case we review all the alternatives W_l , $l = \overline{1, L}$ in the course of our random selection, the result will be the values T_l^k for all the alternatives $l = \overline{1, L}$.

6. We define the new distribution of the discrete random variable \tilde{i} using the information obtained in the course of dialogue with the expert.

$$p_i^{k+1} = \frac{p_i^k + \frac{1}{S} \chi(\theta_i^k) \varepsilon^{k+1}}{1 + \varepsilon^{k+1}}, \quad i = \overline{1, I}$$

where ε^{k+1} is the step taken when calculating the probability p_i at $(k + 1)$ -th iteration.

$$\varepsilon^{k+1} = \varepsilon^k \exp \left\{ \frac{M^k}{S} \sum_{i=i_1^k}^{i_S^k} \text{Sign}[\theta_i^{k-1} \cdot \theta_i^k] \right\},$$

θ_i^{k-1} is the value of sign assessment of i -th criterion at $(k - 1)$ -th iteration,

$\chi(a)$ is the characteristic function,

$$\chi(a) = \begin{cases} 1, & \text{if } a > 0, \\ 0, & \text{if } a \leq 0. \end{cases}$$

7. We do sign assessment of significance of alternatives W_l on condition

$$\sum_{i=1}^I p_i^{k+1} \hat{\psi}_i^{W_j} > \sum_{i=1}^I p_i^k \hat{\psi}_i^{W_j}:$$

$$\theta_l^k = \begin{cases} 1, & \text{if } l = j \\ -1, & \text{in the opposite case, } l = \overline{1, L} \end{cases}$$

8. We define the new distribution of discrete random variable \tilde{l} in agreement with sign assessment on condition $\sum_{i=1}^I p_i^{k+1} \hat{\psi}_i^{W_j} > \sum_{i=1}^I p_i^k \hat{\psi}_i^{W_j}$

$$p_l^{k+1} = \frac{p_l^k + \chi(\theta_l^k) \gamma^{k+1}}{1 + \gamma^{k+1}}, \quad l = \overline{1, L},$$

while condition $\sum_{i=1}^I p_i^{k+1} \hat{\psi}_i^{W_j} \leq \sum_{i=1}^I p_i^k \hat{\psi}_i^{W_j}$ yields

$$p_l^{k+1} = p_l^k, \quad l = \overline{1, L}$$

where γ^{k+1} is the step taken to calculate the values of probabilities p_i during $(k + 1)$ -th iteration,

$$\gamma^{k+1} = \gamma^k \exp \left\{ \xi \sum_{l=l_1}^V \text{Sign} \left[\left(\sum_{i=1}^I p_i^k \hat{\psi}_i^{W_j} - \sum_{i=1}^I p_i^{k-1} \hat{\psi}_i^{W_j} \right) \left(\sum_{i=1}^I p_i^{k+1} \hat{\psi}_i^{W_j} - \sum_{i=1}^I p_i^k \hat{\psi}_i^{W_j} \right) \right] \right\},$$

$\xi > 0$ is the prescribed step size.

9. The distribution of discrete random variable \tilde{d} remains unchanged:

$$p_d^k = p_d^1, \quad d = \overline{1, D}$$

10. The above man-machine procedure is stopped after searching through all the alternatives W_l , $l = \overline{1, L}$.

11. The best option W^* is selected as following:

1) We define the sub-set of alternatives $L_1^* : \max_l T_l^k$;

2) We define the sub-set of alternatives $L_2^* : \max_{i=1}^I \sum p_i^k \hat{\psi}_i^{W_l}$;

3) We choose

$$W_i^* : \max_{i=1}^I \sum p_i^k \hat{\psi}_i^{W_l}$$

$$l \in L_1^* \cap L_2^*$$

as the best alternative option.

Finally: $W^* = W_l^*$.

Now we proceed to explain adaptation inside the team of real and virtual experts in randomized environment. First, it becomes possible to assess in the dialogue mode the degree of satisfaction with the newly obtained values of criteria by a single expert for a single alternative at k -th step.

Following the distribution $p_d^1, d = \overline{1, D}$, it is particularly the experts who offer ranking assessments of significance of criteria closest to the averages that are involved more often in the dialogue, i.e. experts with most coherent assessments.

Distribution $p_i, i = \overline{1, I}$ is tuned for higher significance of probabilities of those criteria that most often show the strongest disagreement with experts agreed on various alternatives. Note that accounting for the algorithm of tuning $p_l, l = \overline{1, L}$ and selecting through all the alternatives, the probabilities of involving alternatives for expert assessment increase for higher average value of weighted convolution $\sum_{i=1}^I p_i^k \cdot \hat{\psi}_i^{W_l}$.

Upon a certain number of iterations for the alternative that represents the best combination of values of criteria, for example, l_1 , the probability p_{l_1} occupies a large part of the interval $[0, 1]$, forcing the other alternatives out, since other probabilities become considerably smaller than p_{l_1} . In other words, experts have the alternative l_1 presented oftener for assessment and it is on that alternative that experts finally agree in their opinion on the significance of criteria and distribution p_i^k stabilizes. It is then said that p_i^k were obtained by adapting weight coefficients of criteria in the weighted average convolution

$$\sum_{i=1}^I \alpha_i \hat{\psi}_i, \quad 0 \leq \alpha_i \leq 1, \quad \sum_{i=1}^I \alpha_i = 1,$$

where $\alpha_i = p_i^k$, since $0 \leq p_i^k \leq 1, \sum_{i=1}^I p_i^k = 1$.

Choosing the size of the step for the second level $\varepsilon^{k+2}, \gamma^{k+1}$ is organized so that, first, the value of membership function calculated for the specific grade of linguistic variable is used to tune probabilities p_i , and, second, the aftereffect of expert's answer on $(k - 1)$ -th iteration is accounted for to tune p_i and p_l . The latter makes it possible to change significantly the distribution of probabilities, provided expert assessments coincide on the $(k - 1)$ -th and k -th iterations; no sharp changes are introduced if there is no such coincidence.

The structural flowchart for the team mode selection algorithm in virtual expert environment is shown in figure 4.

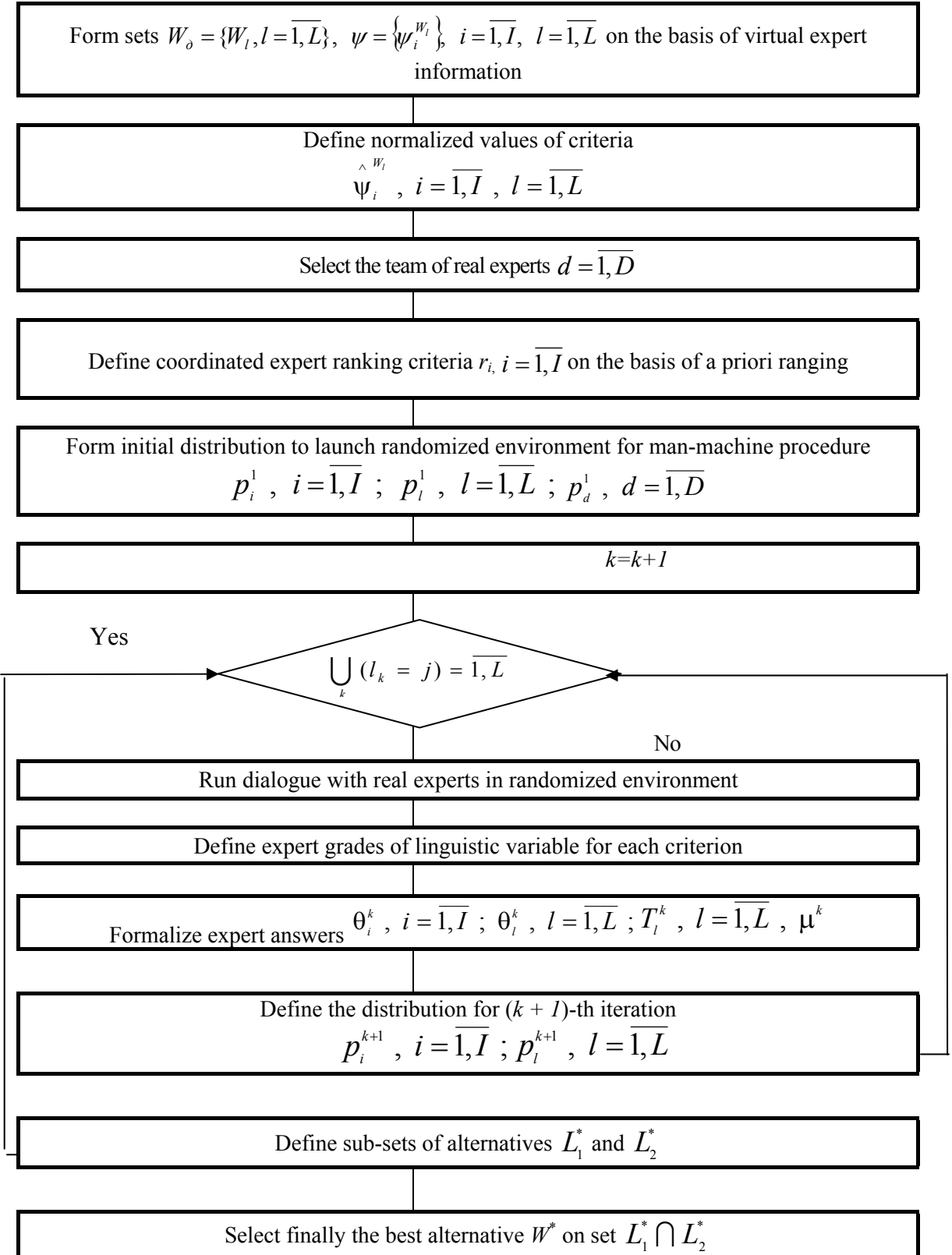

Figure 4. Team mode selection in virtual expert environment. Algorithm structural flowchart

4. Team interaction of experts of equal rank

Team mode with dominating expert is based on agreeing the assessments of priority of alternative optional managerial decisions by that expert with assessments by a team of peer experts [5, 6].

Assume that the dominating expert's number is $d = 1$, while other experts belong to $d = \overline{2, D}$. Going by their experience of interacting with a dominating expert (manager) and accounting for their intuition, logical analysis and experience these other experts use the question-answer procedure to assess the effectiveness of each alternative $W_l, l = \overline{1, L}$ proposed by expert $\#d = 1$.

To organize the question-answer session we form a special linguistic structure. At the first stage we connect valuation of alternatives $W_l, l = \overline{1, L}$ by experts $d = \overline{2, D}$ with distributing all such alternatives into 3 classes that correspond to the effectiveness of the chosen decision:

- class A: the alternative W_l is effective with probability close to 1;
- class B: the alternative W_l is ineffective with probability close to 1;
- class C: the alternative W_l is effective with probability less than 0.5.

Expert $\#d = 1$ presents his/her assessed allocation of alternatives $W_l, l = \overline{1, L}$ to classes A, B, C.

Valuation by experts $d = \overline{2, D}$ is based on the dialogue composed of answers to K questions of alternative form:

$$\alpha = (\alpha_1, \dots, \alpha_k, \dots, \alpha_K).$$

The task of constructing linguistic structure during the second stage consists in selecting such number of questions K that would make it possible to assess the degree of agreement (state β) between the dominating expert and each of $d = \overline{2, D}$ experts of equal rank. To retrieve the value of K we use the entropy approach [14-16].

With three classes available for the dominating expert and experts of equal rank to distribute alternatives to, state β has nine possible outcomes that remain equally probable prior to the dialogue procedure. Hence, the entropy $\mathfrak{E}(\beta) = \log 9$. Meanwhile alternative questions that accept positive or negative answers only yield the entropy of the dialogue mode α :

$$\mathfrak{E}(\alpha) \leq K \log 2,$$

where $\mathfrak{E}(\alpha) = \log 2$ for alternative answers.

Information obtained in the dialogue mode has to be at least as diverse as the outcomes for state β , which yields a relationship

$$\mathfrak{E}(\alpha) \geq \mathfrak{E}(\beta)$$

or

$$K \log 2 \geq \log 9.$$

Therefore, $K \geq \frac{\log 9}{\log 2}$, i.e. $K \geq 4$.

As for the third stage of constructing linguistic structure it is suggested to organize question-answer exchange as a sequence of four questions for each alternative W_l , $l = \overline{1, L}$:

1. Has expert $d = 1$ correctly rated alternative W_l to class A or B?
2. Has expert $d = 1$ correctly rated alternative W_l to class B?
3. Does expert of $d = \overline{2, D}$ believe alternative W_l to be effective with a probability higher than 0.5?
4. Has expert $d = 1$ correctly rated alternative W_l to class A?

Alternative answers (1,0) to the above questions yield $2^4 = 16$ situations. Meanwhile, placing alternative W_l in class A, B or C produces 9 situations only, i. e. 4 questions are redundant. However, having $2^3 = 8$ questions would prevent clearing all 9 situations. Table 4.1 below shows the decisions in dependence of answers to all the 4 questions.

Table 4.1. Adopted decisions

No.	Question 1	Question 2	Question 3	Question 4	Adopted decision
1	1	1	1	1	A
2	0	1	1	1	C
3	1	0	1	1	A
4	0	0	1	1	–
5	1	1	0	1	A
6	0	1	0	1	–
7	1	0	0	1	–
8	0	0	0	1	–
9	1	1	1	0	C
10	0	1	1	0	C
11	1	0	1	0	B
12	0	0	1	0	–
13	1	1	0	0	B
14	0	1	0	0	–
15	1	0	0	0	B
16	0	0	0	0	–

Answers by experts in the question-answer mode should be treated as voting on l -th alternative $l = \overline{2, L}$, the votes distributed into three classes A, B and C:

$$N_{A_j}^A, N_{B_j}^B, N_{C_j}^C.$$

Following the majority rule (Γ_{31}), the final decision according to expert valuation consists in putting it with the class of maximum N_{w_i} .

In case $N_{w_i} = N_{w_i}^A$, the alternative W_i contends for the optimal decision but needs coordination with the dominating expert. The final decision on the set of alternatives corresponding to that condition is taken by the dominating expert (Γ_{32}).

Therefore, the question-answer procedure combined with the leading role of valuation by the dominating expert helps to choose the optimal decision W^* in team mode.

The dominating expert may agree with opinions by experts of equal rank and choose an optimal decision on condition:

$$W^* \rightarrow \max_i \{W_i : N_{w_i}\}$$

In other case the dominating expert may choose an alternative W_i ($N_{w_j} < N_{w_i}^*$) as his/her best decision and apply the algorithm placing W_i among the leaders additionally, provided the respective resource is available and it is possible to define the influence of that resource on winning the leading position [17-19].

The structural flowchart of team mode selection algorithm with dominating expert is shown in figure 5.

Conclusion

As a result of the undertaken study, a set of algorithms for interaction of components of an expert and virtual resource of a procedural type in optimal managerial decision making, is developed. The algorithm of virtual mode of interaction, based on the basic procedure of multialternative optimization; dual regime based on the matrix game development; collective mode of peer experts interaction, based on the iterative principle with immersion of question-answer process with a team of real experts in a randomized environment; collective mode with a dominant expert, based on the process of harmonizing its priority assessments with those of alternative managerial decision options provided by peer experts. The developed algorithms can be integrated into the single environment of a decision-making system and be used as a means of intellectual support.

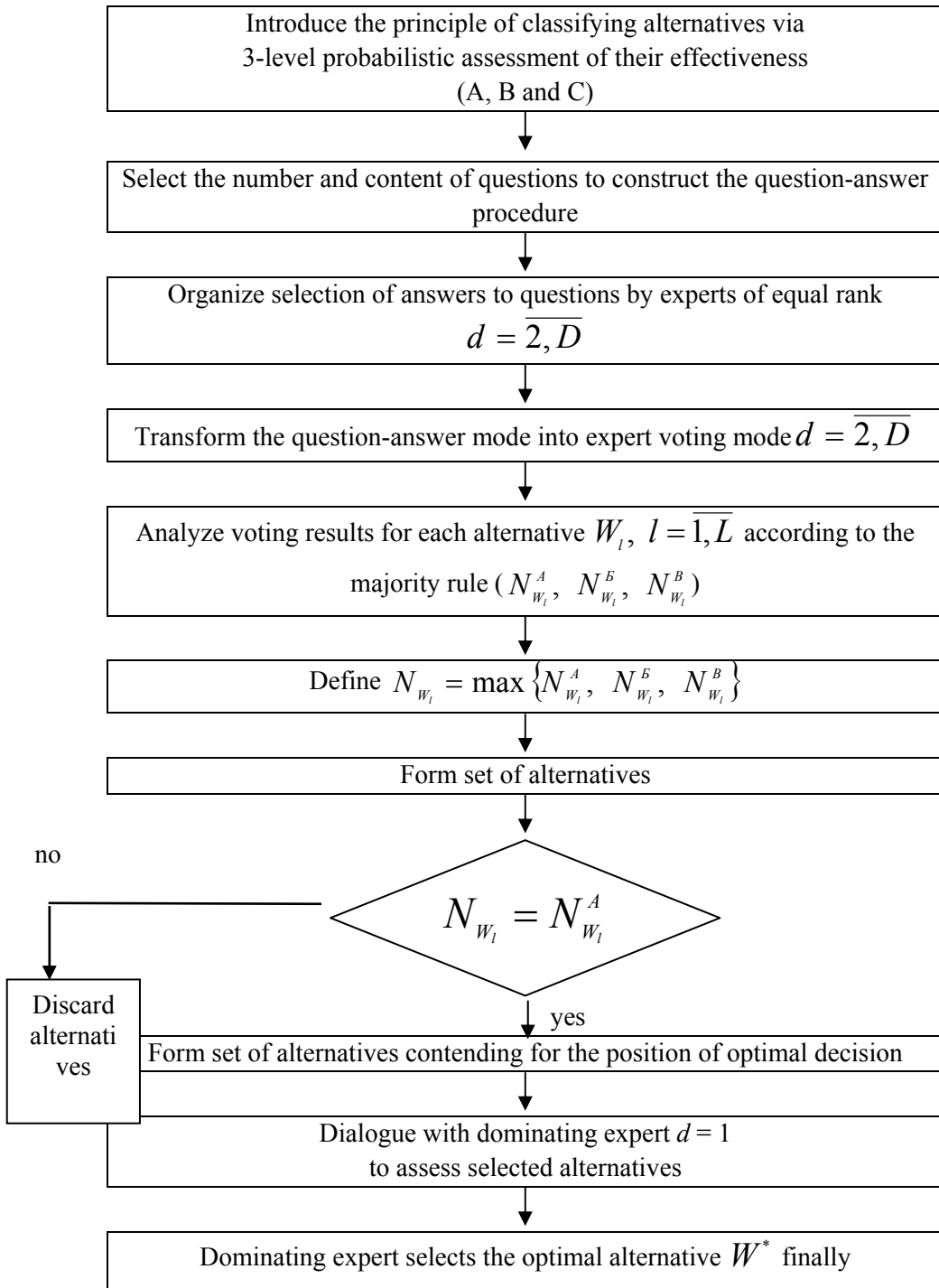

Figure 5. Team mode selection algorithm with dominating expert

References

- [1] SCHINDLER, F. 2015. Algorithmization of decision-making in management of objects with inhomogeneous characteristics. In: *Information Technology Applications*. Bratislava: PEVS-VVV, 2015. ISSN 1338-6468, no. 1, p. 13-22.
- [2] RUZICKY, E. 2015. Formalization of user interaction with virtual expert resource of knowledge type via ontological modelling. In: *Information Technology Applications*. Bratislava: PEVS-VVV, 2015. ISSN 1338-6468, no. 1, p.33-43.
- [3] SPERKA, M. 2015. Special aspects and principles of identification of objects with inhomogeneous characteristics. In: *Information Technology Applications*. Bratislava: PEVS-VVV, 2015. ISSN 1338-6468, no. 1, p. 3-12.
- [4] LVOVICH, I., LVOVICH, Y., CHOPOROV, O. 2015. Building of semi-quantile regression models. In: *Information Technology Applications*. Bratislava: PEVS-VVV, 2015. ISSN 1338-6468, no. 1, p.91-110.
- [5] LVOVICH, Y. 2006. *Multialternative Optimization: Theory and Applications*. Voronezh: The publishing house "Quart", 2006, 415 p.
- [6] PENKOV, P.V. 2012. Expert methods to improve control systems In: *Herald of the Voronezh Institute of High Technologies*. 2012. no. 9. p. 108-110.
- [7] ZEMLYANUHINA, N.S. 2012. On the Application of Information Technologies in Management In: *Successes of modern science*. 2012. no. 6, p. 106-107.
- [8] PREOBRAZHENSKY, Y.P., PANEVIN R.Y. 2010. The wording and classification of problems of optimal control of production facilities In: *Bulletin of Voronezh State Technical University*. 2010. vol. 6, no. 5, p. 99-102.
- [9] CHOPOROV, O.N., CHUPEEV, A.N., BREGEDA, S.Y. 2008. Significance Methods of analysis parameters in the classification and predictive modeling In: *Bulletin of Voronezh State Technical University*. 2008. vol. 4, no. 9, p. 92-94.
- [10] ZYABLOV, E. L., PREOBRAZHENSKY, Y.P., ZYABLOV, E.L. 2008. Building object-semantic model of the control system In: *Herald of the Voronezh Institute of High Technologies*. 2008. no. 3, p. 029-030.
- [11] LISITSKY, D.S, PREOBRAZHENSKY, Y.P. 2008 Building a simulation model of socio-economic /In: *Herald of the Voronezh Institute of High Technologies*. 2008. no. 3, p. 135-136.
- [12] MOSKALCHUK, Y.I., NAUMOVA, E.G., KISELEVA, E.V. 2013. Problems of optimization of innovation processes in organizations In: *Simulation, optimization and information technology*. 2013. no. 2, p. 10.
- [13] KOROLKOV, R.V. 2013. On the financial management of the organization In: *Herald of the Voronezh Institute of High Technologies*. 2013. no. 11, p. 144-147.
- [14] ZAVYALOV, D.V. 2013. On the Application of Information Technology In: *Modern high technologies*. 2013. no. 8-1, p. 71-72.
- [15] GUSKOVA L.B. 2012. On the construction of the automated work place manager In: *Successes of modern science*. 2012. no. 6, p. 106.
- [16] RODIONOVA, K.Y. 2012. Globalization of the world economy: the nature and contradictions In: *Herald of the Voronezh Institute of High Technologies*. 2012. no. 9, p. 185-186.
- [17] FEDOTOVA, S.A. 2011. The World Economy: the main stages of formation and development of modern trends In: *Herald of the Voronezh Institute of High Technologies*. 2011. no. 8, p. 133-136.

- [18] SHISHKINA, Y. M., BOLUCHEVSKAYA, O.A. 2011. Public administration
In: *Recent studies of social problems*. 2011. T. 6. no. 2, p. 241-242.
- [19] LVOVICH Y.E. 2006. *Multialternative Optimization: Theory and Applications*
Voronezh, 2006, the publishing house "Quart", 415 p.

Prof. Yakov Lvovich, D. Sc.

the honored scientist of the Russian Academy of Natural Sciences
President of Voronezh Institute of High Technologies
office@vivt.ru

Prof. Oleg Choporov, D. Sc.

Voronezh Institute of High Technologies
choporov_oleg@mail.ru

Doc. Andrew Preobrazhensky

Voronezh Institute of High Technologies
app@vivt.ru



The development of CAD of information systems and software for diffractive structures

Igor Lvovich, Andrew Preobrazhensky, Oleg Choporov

Abstract:

The CAD development of diffraction devices is one of the promising directions for development of computer-aided design, and antenna equipment. In this paper the basic features of CAD development of electronic devices are introduced. For optimal choice of basic elements for radar antennas in the analysis of radar characteristics, it's recommended to use the principle of maximal correlation coefficient of selected basic elements parameters and the required characteristics of electromagnetic waves scattering, as well as cost characteristics of the antenna along with the desired characteristics and technical specifications of the automated design. The structural scheme of CAD diffractive structure is examined in detail. The operation of the CAD program head and the structure of information support for CAD and its relations with the software are described.

Keywords:

Simulation modeling, CAD, scattering of electromagnetic waves, radar antenna.

ACM Computing Classification System:

Equation and inequality solving algorithms, Parallel programming languages, Optimization algorithms.

▀ Introduction

The lenses of radar signals (radar target) space, air, land, water and energy converters of electromagnetic waves (banners, a means of reducing the visibility in the radio waves, the antenna of the microwave and EHF ranges) as a rule, are characterized by their large electrical size, complex geometry, presence of absorbing and non-linear elements. Analysis and synthesis of the above-mentioned electrodynamic objects based on rough

ideas about proceeding in which physical processes carry the risk of significant and barely controllable errors in the evaluation of their main characteristics, which, as a rule, quickly change with frequency, polarization and angle of incidence of electromagnetic waves. Measurement of basic characteristics of radar targets (polarization matrix, effective surface scattering in monostatic and bi-static modes scattering) in a wide frequency range and broad angular sector requires a certified or specially equipped antenna of a polygon, or a certified anechoic chamber (the cost of which can provide several million dollars), and large expenditures of time and resources.

For the optimal choice of the basic elements of radar antennas in the analysis of radar characteristics [1-3], you may use the principle of maximal correlation coefficient of selected parameters of basic elements and the required characteristics of scattering of electromagnetic waves, as well as cost characteristics of the antenna with the desired characteristics and technical specifications for automated design. The use of the system of weights of importance of basic parameters and characteristics of user-defined CAD, severely limits the number of possible design options.

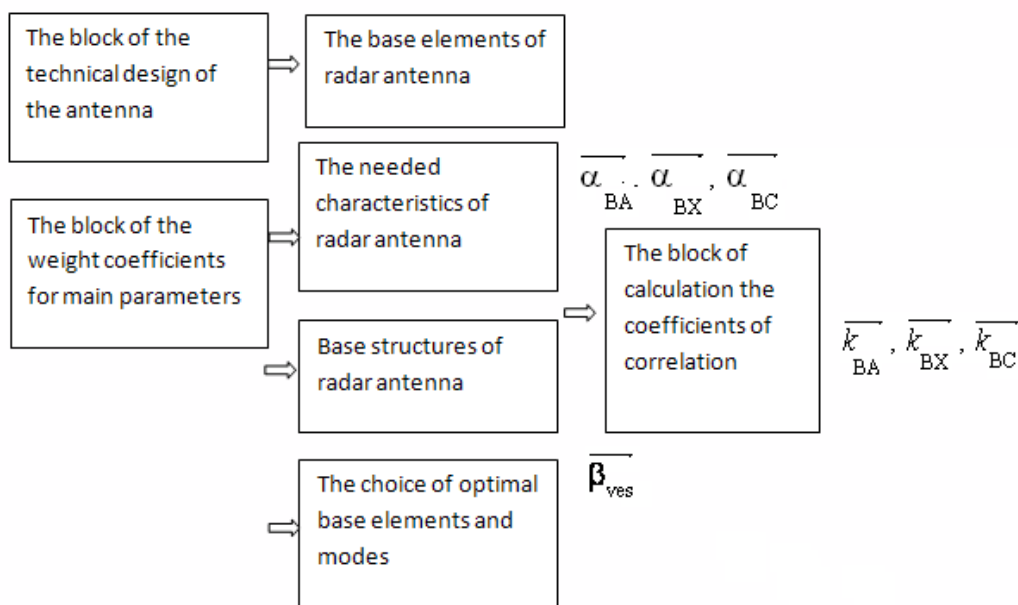

Figure 1. Flowchart of making design decisions using the principle of maximum correlation coefficient

The block diagram of this stage is shown in Fig. 1 using the following notation: $\vec{\alpha}_{T3}$ is a vector, each element of which is a function of a certain number of variables (e.g., frequency, azimuthal and elevation coordinates, etc.) corresponding to the technical task;

$\vec{\alpha}_{BA}, \vec{\alpha}_{BX}, \vec{\alpha}_{BC}$ – vectors containing the appropriate dependencies for the basic elements of antennas, the required values of radar characteristics and basic structures of antennas respectively;

$\vec{\beta}_{ves}$ – the vector of weights of importance of basic parameters and characteristics of antennas;

$\overline{k_{BA}}, \overline{k_{BO}}, \overline{k_{BN}}$ – vectors containing the appropriate correlation coefficients.

The need for prior analysis of the basic elements caused by a significant amount and complexity of the processes occurring in real antennas. In addition, this approach is due to the impossibility of constructing a simple equivalent model of arbitrary diffractive structures.

Developed in the present work, CAD diffractive structures have the following features [4-7]:

- usage along with rigorous methods of mathematical modeling of heuristic methods have a narrow scope;
- diversity and object oriented physical-mathematical models, which are based on implemented algorithms in the framework of CAD and programs to improve performance of solving the problems of modeling;
- lack of a unified mathematical apparatus developed in the CAD system, limiting the scope of its tasks;
- support for expansion of the variety of designed objects due to the modular organization of CAD.

The structure of the developed CAD system is depicted in figure 2.

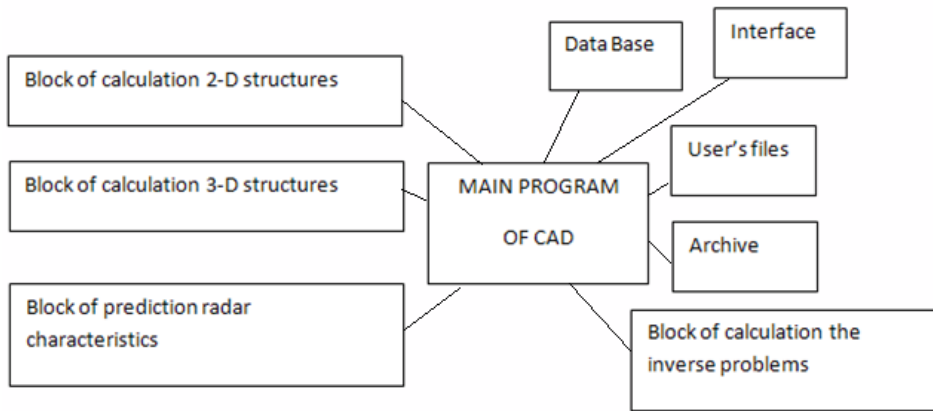

Figure 2. The structural scheme of CAD diffractive structures

Database management system (DBMS) database is characterized by the use of a relational data model. In the database (DB) stored key parameters and dependencies that characterize standard elements included in the composition of technical objects (cylinders, wedges, hollow structure (cavity), etc.) and materials (metals, dielectrics, magneto-dielectric). Each type of basic elements and materials may be characterized by its set of numerical parameters. The sets of components for the same type are presented in tables in first normal form.

The archive is used to store user files, designed for specific tasks-aided design and modeling. Classification of tasks for the archive of information is compiled by the user. They must be continuously updated and expanded when working with CAD.

The unit of calculation for scattering characteristics of two-dimensional structures allows anyone to calculate the scattering parameters. The unit of calculation of scattering characteristics of three-dimensional structures allows to calculate the scattering parameters. Functions for the block of prediction of radar characteristics include the prediction of

scattering characteristics for diffractive structures. Forecasting is based on data from a data block.

The block for solving inverse problems of scattering of electromagnetic waves allows to predict the shape of the object in the restored premises of the reflectors, the prediction of the characteristics of radar absorbing materials and coatings applied to the surface of the object.

The unit for calculation of scattering characteristics of antennas, using blocks calculating the scattering characteristics of two-dimensional and three-dimensional structures allows calculation of characteristics of two-dimensional periodic gratings and metal-dielectric antennas, the calculation of the characteristics of horn-gap excitation of the diffraction element antenna arrays for microwave range of wavelengths, and the scattering characteristics of dipole antennas.

The main program controls all CAD blocks and coordinates the sharing of information between interconnected functional blocks. Its operation is illustrated in figure 3.

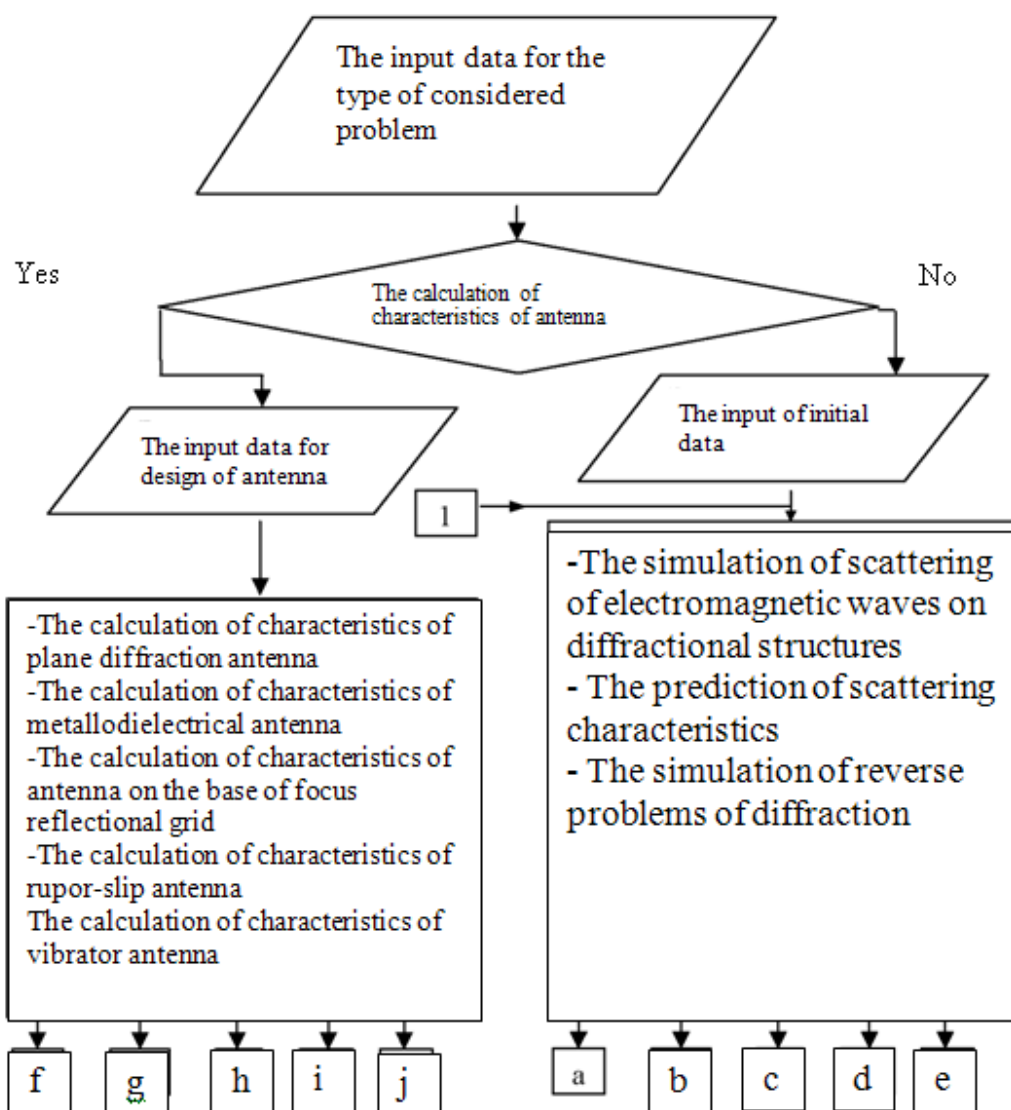

Figure 3. The operation of the head of a CAD program (sheet 1)

As we can see from figure 3-4, CAD diffractive structures and antennas consists of two main parts – analysis of diffraction patterns and diffraction analysis of antennas.

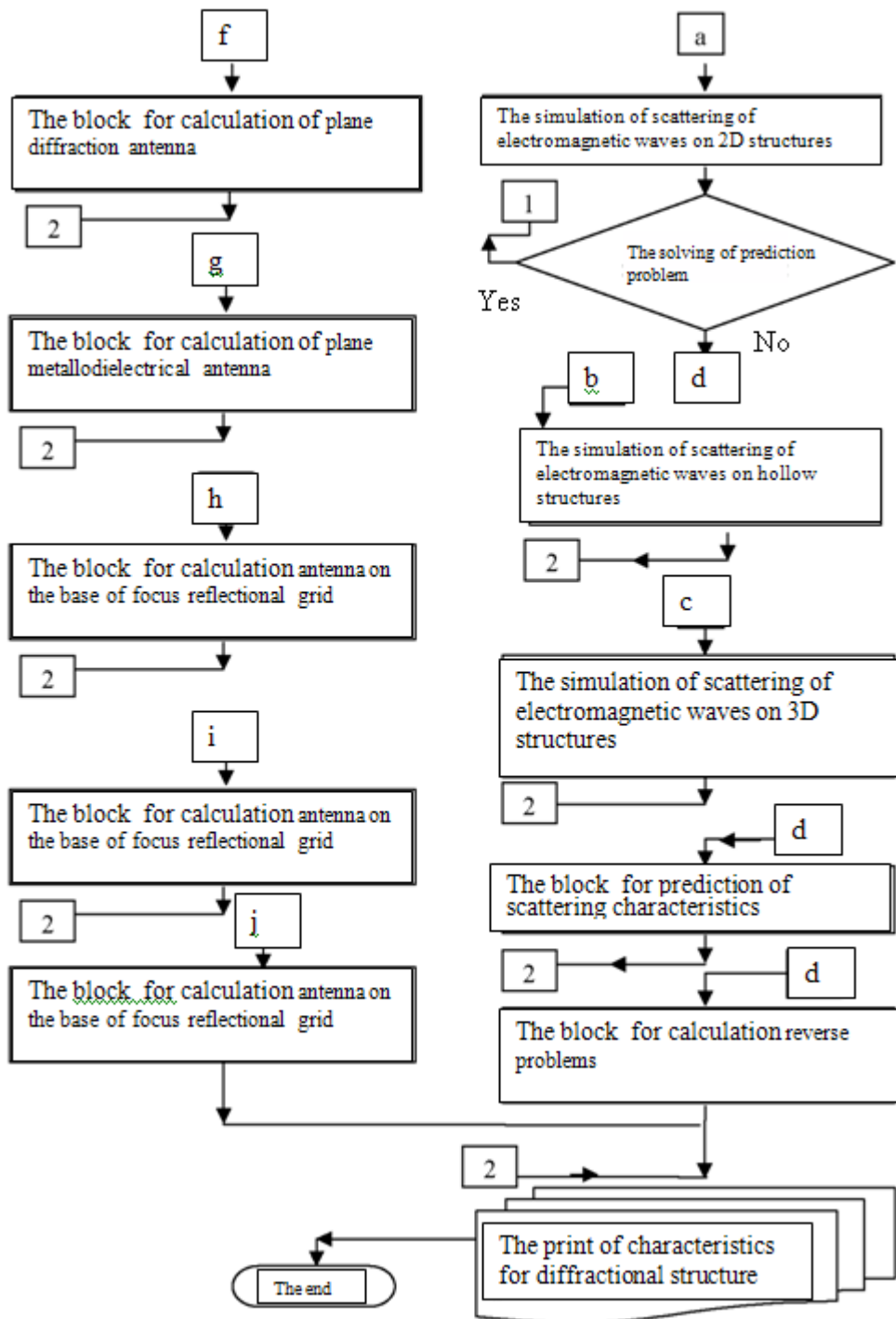

Figure. 4. The operation of the head of a CAD program (sheet 2)

Structural synthesis of antennas is based on the optimal choice of combinations of basic structures of radar antennas, basic antenna elements, the required values of radar characteristics. The optimality chosen criterion is the maximum of the correlation coefficient between the given and design specifications of antennas, depending on the specific base elements of the structural scheme and mode.

Specification for the design of radar antennas could be represented as a vector $\overrightarrow{\alpha_{T3}}$, each element of which is a function of a certain number of variables (e.g., frequency, azimuthal and elevation coordinates $(\eta_1, \eta_2, \dots, \eta_L)$, etc.). The elements of this vector may be, for example, the functional dependence of the gain of the radar antenna, its efficiency, VSWR, cross-polarized radiation, slope, angle-frequency characteristics of the antenna, etc. Denote by $\overrightarrow{\alpha_{VA}}, \overrightarrow{\alpha_{BV}}, \overrightarrow{\alpha_{BC}}$, the vector-function containing the appropriate dependencies to the underlying antenna elements, the required values of the characteristics, the basic structures of antennas, and using the vector of weights $\overrightarrow{\beta_{ves}}$ of importance of basic parameters and characteristics of antennas, determined based on customer requirements to design the antenna. All the above vectors have the same dimension K .

The set of vectors for each stage of making design decisions (selection of the basic elements, values of the characteristics, the basic structures of the antenna) forms a rectangular matrix, the number of rows corresponds to the number of source options for each stage: $\Delta_{VA} = (\overrightarrow{\alpha_{VA1}} \dots \overrightarrow{\alpha_{VAN}})$, $\Delta_{BV} = (\overrightarrow{\alpha_{BV1}} \dots \overrightarrow{\alpha_{BVM}})$, $\Delta_{BC} = (\overrightarrow{\alpha_{BC1}} \dots \overrightarrow{\alpha_{BCQ}})$ [8].

The process of structural synthesis of antenna is reduced to the following series of procedures to find maximums of the respective correlation coefficients

$$\overline{k_{VAj}} = \sum_{i=1}^K \frac{\beta_{vesi} \cdot \int_{S_1 S_2 \dots S_L} \overrightarrow{\alpha_{VAij}}(\eta_1, \eta_2 \dots \eta_L) \cdot \overrightarrow{\alpha_{\dot{\alpha}_i}}(\eta_1, \eta_2 \dots \eta_L) d\eta_1 d\eta_2 \dots d\eta_L}{\sqrt{\int_{S_1 S_2 \dots S_L} \overrightarrow{\alpha_{VAij}}(\eta_1, \eta_2 \dots \eta_L)^2 d\eta_1 d\eta_2 \dots d\eta_L \times \int_{S_1 S_2 \dots S_L} \overrightarrow{\alpha_{\dot{\alpha}_i}}(\eta_1, \eta_2 \dots \eta_L)^2 d\eta_1 d\eta_2 \dots d\eta_L}},$$

$$j = 1, \dots, N$$

$$\overline{k_{BVj}} = \sum_{i=1}^K \frac{\beta_{vesi} \cdot \int_{S_1 S_2 \dots S_L} \overrightarrow{\alpha_{BVij}}(\eta_1, \eta_2 \dots \eta_L) \cdot \overrightarrow{\alpha_{\dot{\alpha}_i}}(\eta_1, \eta_2 \dots \eta_L) d\eta_1 d\eta_2 \dots d\eta_L}{\sqrt{\int_{S_1 S_2 \dots S_L} \overrightarrow{\alpha_{BVij}}(\eta_1, \eta_2 \dots \eta_L)^2 d\eta_1 d\eta_2 \dots d\eta_L \times \int_{S_1 S_2 \dots S_L} \overrightarrow{\alpha_{\dot{\alpha}_i}}(\eta_1, \eta_2 \dots \eta_L)^2 d\eta_1 d\eta_2 \dots d\eta_L}},$$

$$j = 1, \dots, M$$

$$\overline{k_{BNj}} = \sum_{i=1}^K \frac{\beta_{vesi} \cdot \int_{S_1 S_2 \dots S_L} \overrightarrow{\alpha_{BNij}}(\eta_1, \eta_2 \dots \eta_L) \cdot \overrightarrow{\alpha_{\dot{\alpha}_i}}(\eta_1, \eta_2 \dots \eta_L) d\eta_1 d\eta_2 \dots d\eta_L}{\sqrt{\int_{S_1 S_2 \dots S_L} \overrightarrow{\alpha_{BNij}}(\eta_1, \eta_2 \dots \eta_L)^2 d\eta_1 d\eta_2 \dots d\eta_L \times \int_{S_1 S_2 \dots S_L} \overrightarrow{\alpha_{\dot{\alpha}_i}}(\eta_1, \eta_2 \dots \eta_L)^2 d\eta_1 d\eta_2 \dots d\eta_L}},$$

$$j = 1, \dots, Q$$

where S_1, S_2, \dots, S_L – the range of the parameters $(\eta_1, \eta_2, \dots, \eta_L)$.

For each of the vectors of correlation coefficients using standard procedures we get the maximum elements, numbers of which correspond to the optimum for a given technical specifications for the design of basic antenna elements, values of the characteristics, and basic structures of antennas.

Software modules have user-friendly interface and may be maximized to fit the window when developing CAD was made by C++ Builder. The response time for one specific module using a PC with a Pentium III-900 can be in the range from several seconds to several tens of minutes. The desirable volume of the computer's RAM – at least 256 MB (the order of matrices solving systems of linear algebraic equations might reach 3000 up to 5000) - free hard disk capacity – 200 MB.

The database has a file structure and carries out the input, storing, searching and providing information about the characteristics and parameters:

- standard elements and diffractive structures;
- basic elements of diffraction antennas and metal-dielectric antennas;
- tabulation according to functions for calculation of which is required considerable machine time (for example functions involving integrals used to determine the scattering characteristics of diffractive structures);
 - source data of all ongoing projects;
 - intermediate data arrays organized in the form of temporary files;
 - electrodynamic models of diffraction structures, and antennas formed as a result of design.

For communication with the user the user interaction program is divided into the graphical interface program and processing program along with object-oriented messages [62, 198-199].

The program processing object-oriented messages allows you to enter source data and to modify the database using the special text forms and queries.

The dialog mode is performed by engaging the drop-down system menus that allow you to enter raw data into a user-friendly form to manage the process of formation of electrodynamic models, mathematical and optimization models, modifications of the database contents, ability to choose various views for simulation results, optimization and automated design (in the form of the surface, maps of lines of equal level, the family of graphs in cartesian or polar coordinates, tables, etc.), management of communication with the database or other CAD programs.

CAD structure software allows us to develop several simultaneously running projects. The source data for each project is stored as a file in the database. The model is created and updated with a special project file that contains the description of the generated model. In the case of an adequate model, this file is stored in the database. Intermediate results may be stored as external files or in the computer memory or they are removed automatically.

The composition of the structural scheme of data transmission and management is the communication interface with the database and other hardware-software units that allow to carry out data entry and to communicate these findings in an external subsystem or the database. The communication interface also converts the files used by the CAD format for external programs or databases.

The structure of information support of CAD and its relationships with the software is shown in Fig. 4. The database contains files with names MPL (the library of electrodynamic parameters of materials), SEL (a library of standard diffractive structures), SCL (a library of basic structural patterns of diffraction antennas), TFL (library of tabulat-

ed functions), and the file extensions .trd (source projects).edm (the project files for the generated electrodynamic models) .rez (files of results of models and computer-aided design), .tmp (intermediate data).

Database management provides the monitor module that is being used as a text editor module database correction database (CDB) program processing object-oriented messages. The MPL, SEL, BAL, BEL, SCL, BVL, SAL, PSL, TFL files have the extension .dbf and are stored in a database format of Builder C++. This fact allows us to minimize the size of files maintaining compatibility with the most common databases. Other files commonly used in CAD systems are used in plain text format view of the data [9].

The main indicators characterizing the adequacy of the CAD complex objects are used as follows: "fizicheski" results of mathematical modeling, optimization and computer-aided design;

- stability – small changes in input parameters or technical specifications for the design should correspond to small changes of output parameters and characteristics;
- repeatable results – the same input data are entered in different sequences that must correspond to the output unchanged;
- use of different research methods or projects for the same object should result in measurable results;
- correspondence of the results obtained when using different CAD systems, developed by different teams;
- use of correct mathematical methods, models and algorithms;
- fast convergence exploited in CAD algorithms;
- conformity of the research results or the design object data of experimental and field studies.

Of course, the latter criterion of CAD adequacy is crucial. The indicator "physical reality level" may be a subjective assessment of the quality of computer aided design.

Under property we understand effectiveness of the program ensuring the CAD system to perform a required function without excessive misuse of resources. As an assessment of efficiency one often takes characteristics of the program, the value of which is directly proportional to fast-contribution and inversely proportional to the amount of used resources of the computer and external devices [10-15].

Developing CAD systems as a whole it must meet the above criteria. The adequacy of the overwhelming majority of system functions of automated design for diffractive structures under-firmed positive results of experimental and textural studies analyzed (designed) objects.

In conclusion, the main directions of development and modernization designed by CAD should involve:

- improvement of the CAD interface and the extension of possible use of standard databases;
- inclusion of expanding design and engineering capabilities in the computer-aided design system;
- increase of the possible degree of design automation by increasing the number of operations that CAD systems effectively implements without user intervention;
- increase the effectiveness of CAD.

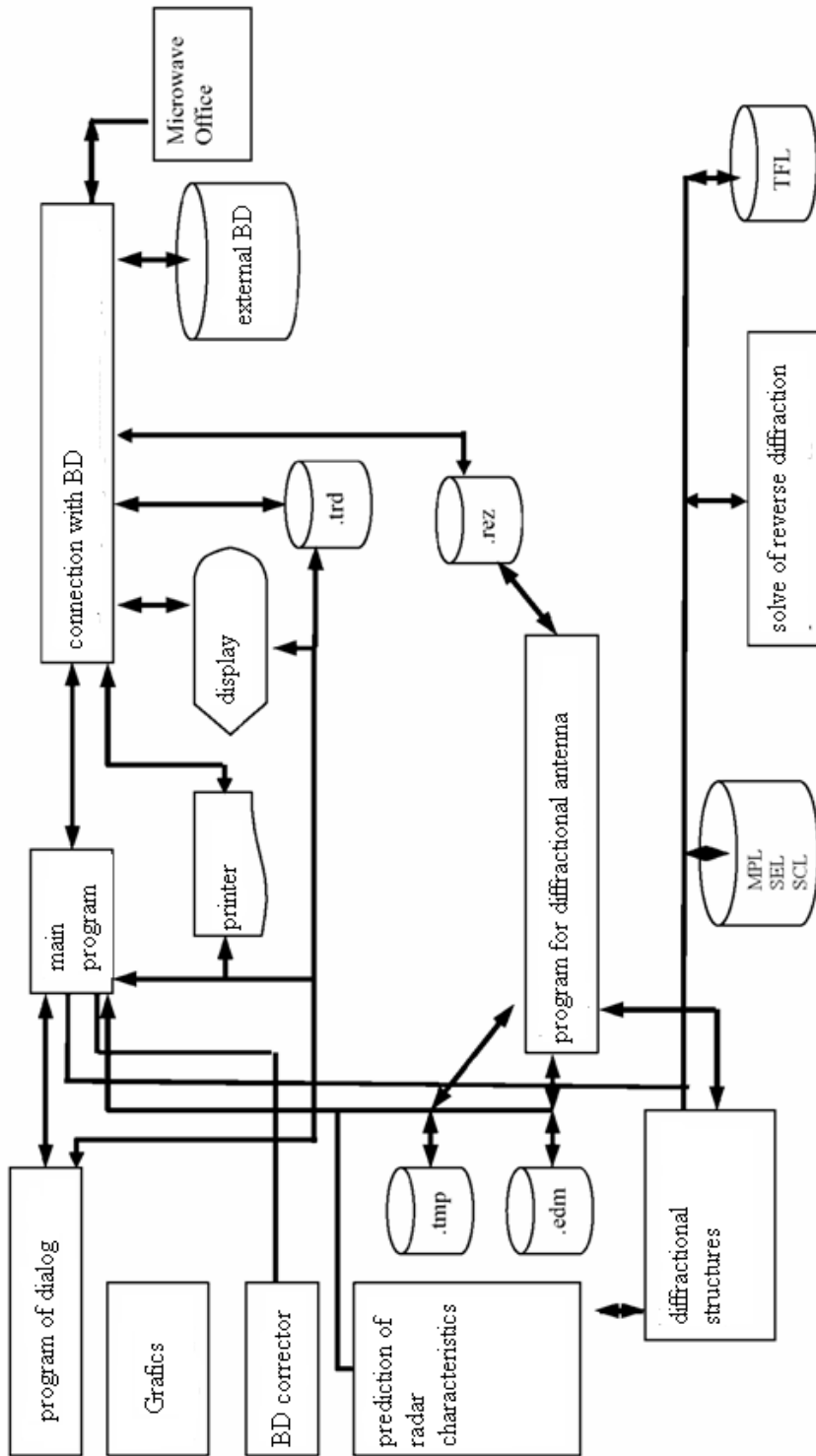

Figure 4. Structure of information support for CAD and its relationships with software

References

- [1] ASTANIN, L., KOSTYLEV, A.A. 1989. *Basics ultrawide band radar measurements*. M.: Radio and Communications, 1989, 305 p.
- [2] BACHRACH, L.D., et al. 1997. *Reference antenna technology*. M.: IPRZHR, 1997, vol. 1, 256 p.
- [3] WEINSTEIN, L.A. 1988. *Electromagnetic waves*. M.: Radio and Communications, 1988, 440 p.
- [4] NORENKOV, M.: *IP-aided design*. Moscow, 2000.
- [5] NORENKOV, M. 2000. IP design automation tools in the electronics. In *Information Technologies*, 2000, no. 10, pp. 31-37.
- [6] NORENKOV, M.: IP-aided design systems. In *Principles of construction and structure IP*. M.: Higher School, 1986, vol. 1, 127 p.
- [7] KORYACHKO, V.P., KUREICHIK, VM, NORENKOV, IP. 1987. *Theoretical Foundations of CAD*. M.: Energoatomisdat, 1987, 400 p.
- [8] KORN, G., KORN, T. 1984. *Mathematical Handbook for Scientists and Engineers*. M.: Nauka, 1984, 831 p.
- [9] BATISHCHEV, D.I., LVOVICH, YE, FROLOV, VN. 1997. *Optimization CAD: Textbook*. Voronezh: VSU, 1997, 416 p.
- [10] MISHIN, JA. 2013. About the computer-aided design systems in wireless networks. In *Herald of the Voronezh Institute of High Technologies*. 2013, no.10, p. 153-156.
- [11] MILOSHENKO, O.V. 2011. Methods for evaluating propagation characteristics in mobile radio communication systems. In *Herald of the Voronezh Institute of High Technologies*. 2011, no. 9, p. 60-62.
- [12] GOLOVINOV, S.O., HROMYH, AA. 2012. Management problems of mobile communication systems. In *Herald of the Voronezh Institute of High Technologies*. 2012, no. 9, p. 13-14.
- [13] LVOVICH, I.J., VORONOV, A.A. 2011. Application of methodological analysis in the safety study. In *Information and Security*. 2011, vol. 14, no. 3, p. 469-470.
- [14] ERASOV, S.V. 2013. Optimising processes in the electrodynamic problems. In *Herald of the Voronezh Institute of High Technologies*. 2013, no. 10, p. 20-26.
- [15] BOLUCHEVSKAYA, O.A., GORBENKO, O.N. 2013. The properties of the scattering characteristics of the evaluation methods of electromagnetic waves. In *Simulation, optimization and information technology*. 2013, no. 3, p. 4.

.....

Prof. Igor Lvovich, D. Sc.

Pan-European University, Bratislava, Slovakia
office@vivt.ru

Doc. Andrew Preobrazhensky

Voronezh Institute of High Technologies
app@vivt.ru

Prof. Oleg Choporov, D. Sc.

Voronezh Institute of High Technologies
choporov_oleg@mail.ru



Modeling of scattering of electromagnetic waves on the base of multialternative optimization

Yakov Lvovich, Andrew Preobrazhensky, Oleg Choporov

Abstract:

One of the problems arising in management of large systems, is a scattering of electromagnetic waves on complex structures with radio absorbing coatings. In many cases the hollow metallic structures with circular cross section are observed. The modal method was used to estimate the modes in the inner area of the cavity. Tangential components of electric and magnetic fields at the aperture of the cavity excited by a plane electromagnetic wave can be represented in the form of expansions in modes of waveguide with the corresponding unknown modal coefficients. At this stage, the reciprocity theorem of modal coefficients within the relevant cavity modes is determined. Methods of optimization of characteristics of radar absorbing coating are introduced. Determination of the real part of dielectric permeability of radar absorbing coatings in a given thickness of its layer is shown on corresponding figure. Application of absorbing load in the form of the two radar absorbing layers with increasing thickness of one absorbing coating with constant thicknesses of a different radar absorbing coating is introduced. The possibility of achievement of a significant reduction in the level of radar cross section is described.

Keywords:

Simulation modeling, multialternative optimization, scattering of electromagnetic waves, cavity structure.

ACM Computing Classification System:

Equation and inequality solving algorithms, Parallel programming languages, Optimization algorithms.

Introduction

The development of electrodynamic systems of computer-aided design (CAD) allows us to solve a completely new challenge in the field of antenna-feeder equipment, diffraction theory of electromagnetic waves on structures of complex shape that require substantial computing resources and is practically implemented to fulfill many scientific developments, the high degree of complexity of which hindered their practical implementation.

The special class of problems is the study of scattering of electromagnetic waves on the various hollow structures, which can be included in the composition of technical objects of complex shape as elements of design or composition of antenna-feeder devices. The particular interest is in the construction of algorithms of calculation of scattering characteristics of electromagnetic waves of three-dimensional structures. The calculation cannot reduce the dimensionality of the problem (due to the symmetry of an object). The most difficult thing is to research the hollow structure, the dimensions of which correspond to a resonance region.

The calculation of the radar cross section (RCS) of three-dimensional perfectly conducting hollow structures of complex shape with arbitrary cross-section containing radar absorbing materials is a complicated electrodynamic problem. The currently used methods [1-3] to calculate the electrodynamic characteristics of electromagnetic waves is only on hollow structures of some classes, characterized by specific dimensions, shape and cross-sectional hollow structures and methods of placing radar absorbing materials.

At low frequencies, in the resonance region, i.e. when viewed from the hollow structure with aperture size $\sim 1\lambda$, can be used a rigorous method – method of integral equations. For hollow structures with the size of the aperture, comprising several wavelengths, in some cases, it is convenient to use a high frequency approximation [4-6]. There are various high-frequency methods to determine the electromagnetic fields scattered by such structures. One of them is modal method [7].

In practice there are hollow structures, extended in a certain direction and having a uniform cross section along this direction.

In the mathematical modeling of such structures can be represented in the form of a segment of a homogeneous waveguide cross-section. Naturally, this model is one of the simplest models of cavities that are part of real objects. However, such model allows a rigorous modal analysis of the fields inside the hollow structure.

The field inside the structure is represented in the form of an expansion in waveguide modes are known. The unknown modal coefficients are on the basis of the reciprocity theorem [8].

To calculate the RCS of the considered class of structures of hollow rectangular and circular cross section were used modal method. The modern units also include a large number of hollow structures with uniform cross-section, which is close to elliptical (e.g., input and output nozzles, antenna on-Board radio-electronic complexes, the waveguide emitters included in the composition of phased antenna arrays, etc.).

The most fully investigated phased array of waveguides of rectangular and circular cross sections, however, using the well-known advantages of waveguides of more complicated cross-section is elliptical, you can improve range, power and polarization characteristics in a wide angle sector scan.

The parameters describing the shape of the waveguide, give the developer additional degree of freedom for matching the radiator to the space available.

Use in radiators of various absorbing coatings can reduce the reflectance to a sufficiently large sector of the scan when negotiating antenna array with free space.

Thus, due to high incidence of hollow structures of elliptical cross-section the calculation of RCS [9] is an urgent task.

When calculating the RCS three-dimensional hollow structures with elliptical cross-section (unlike, for example, structures with a rectangular cross-section) to reduce the problem to two-dimensional and thus reduce the amount of numerical calculations.

Based on the above it is of interest to develop an algorithm of calculation of RCS hollow structures of elliptical cross-section as containing and not containing radar absorbing coatings, enabling the analysis of propagation of electromagnetic waves inside structures with the specified cross-section.

This will provide an opportunity to identify concrete ways to build structures with a given value of the scattering characteristics of electromagnetic waves.

One of the conditions of creating antennas with specified characteristics is the development of adequate mathematical models and algorithms of calculation of complex diffractive structures that are part of the antennas.

The need to study the diffraction of electromagnetic waves on reflective comb with double periodicity, covered with a layer of dielectric because such a structure can be used to create planar microwave antennas of the diffraction type electronically controlled polarization sensitivity.

The basic idea of e-selection on the basis of polarization is that the comb is positioned orthogonal relative to each other grooves, which are polarization-electoral elements: with parallel mutual orientation of the magnetic field lines incident on the structure electromagnetic waves and grooves of a diffraction grating (DG) excited standing waves of significant intensity.

Thus the reaction of grooves located along the other coordinate axis, on the field of the incident wave is negligible (due to their zapredelnoe to the waves of a given polarization).

Currently, there are no scientific simple mathematical model of the process of mutual transformation of bulk and surface waves in two-dimensional periodic metallic PD is covered with a dielectric. In this paper we consider a mathematical model which enables to obtain useful results for practice.

A well known disadvantage of diffraction antennas – escapologist – can significantly offset by the use of polarization decoupling to transmit information. This problem can be solved by the example antennae consisting of diffraction gratings covered with dielectric waveguide. The calculation of the electromagnetic waves on the grid can be carried out using the apparatus of integral equations and theory of periodic structures.

The type of the equation depends on the structure of the antenna. In the case that the antenna contain metal-dielectric materials in their construction, this is taken into account by introducing into the integral equation corresponding members containing characteristics (e.g., surface impedance) of these materials.

The diffraction grating can be used in diffractive antennas with optical excitation type.

It includes a reflector waveguide with grooves of square cross section filled with a homogeneous dielectric. In the evaluation of the directional diagrams can be used approach on the basis of the two-dimensional model that allows to significantly reduce the need for calculations. The calculation is carried out based on the method of integral equations.

As the excitation elements may be used in horn-slotted emitters.

Practically important is the interest of the development of an algorithm that is based on a strict method of the analysis of such structures.

The use of multiple radar absorbing coatings with specific properties (e.g., thickness) allows to achieve the required values of the scattered electromagnetic field in certain sectors of angles.

Consider the characteristics of dispersion (RCS) waveguide cavities of circular cross-section with a flat absorbing load (fig. 1).

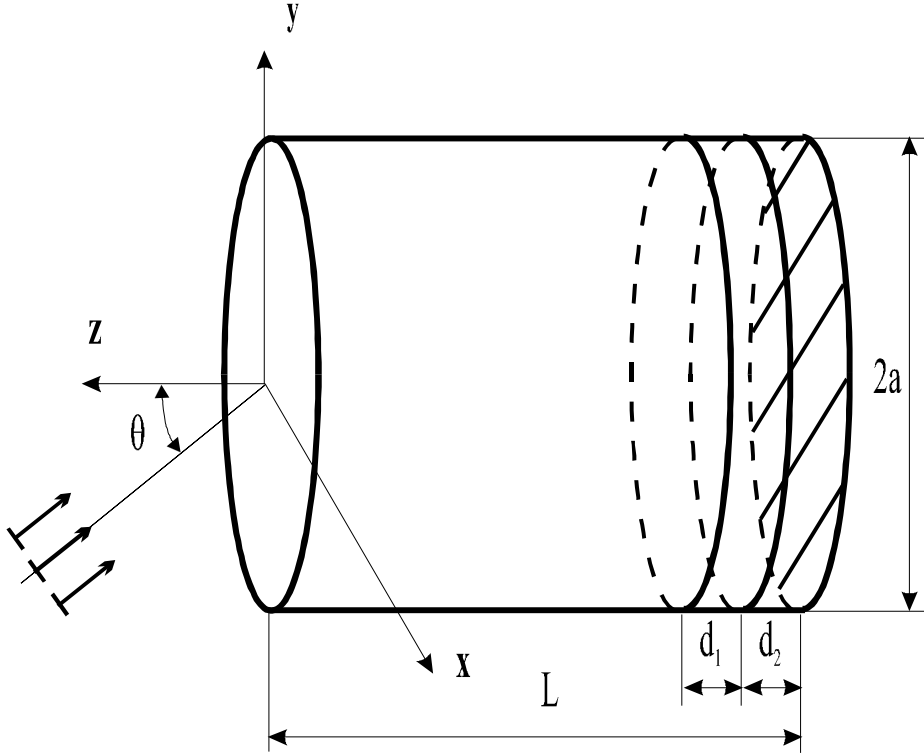

Figure 1. The cavity has a circular cross-section flat with absorptive load

The scattering matrix of a perfectly conducting hollow circular cross-section [10]:

$$\begin{aligned}
 S_{\theta\theta} = & \sum_m \sum_n \frac{j^{2m+1} m^2 (1 + \frac{\gamma_{mn}}{k} \cos \theta)^2 J_m^2(ka \sin \theta)}{\gamma_{mn} \varepsilon_m \sin^2 \theta ((\xi'_{mn})^2 - m^2)} e^{-2j\gamma_{mn}L} + \\
 & + \sum_m \sum_n \frac{j^{2m+1} (\tilde{\gamma}_{mn} + \cos \theta)^2 J_m^2(ka \sin \theta)}{\tilde{\gamma}_{mn} \varepsilon_m \sin^2 \theta (1 - (\frac{\xi_{mn}}{ka \sin \theta})^2)^2} e^{-2j\tilde{\gamma}_{mn}L}, \tag{1}
 \end{aligned}$$

где $\gamma_{mn} = (k^2 - (\xi'_{mn})^2)^{1/2}$, $\tilde{\gamma}_{mn} = (k^2 - (\xi_{mn})^2)^{1/2}$, ξ_{mn} , ξ'_{mn} – the n-th roots of the Bessel function and its derivative, respectively.

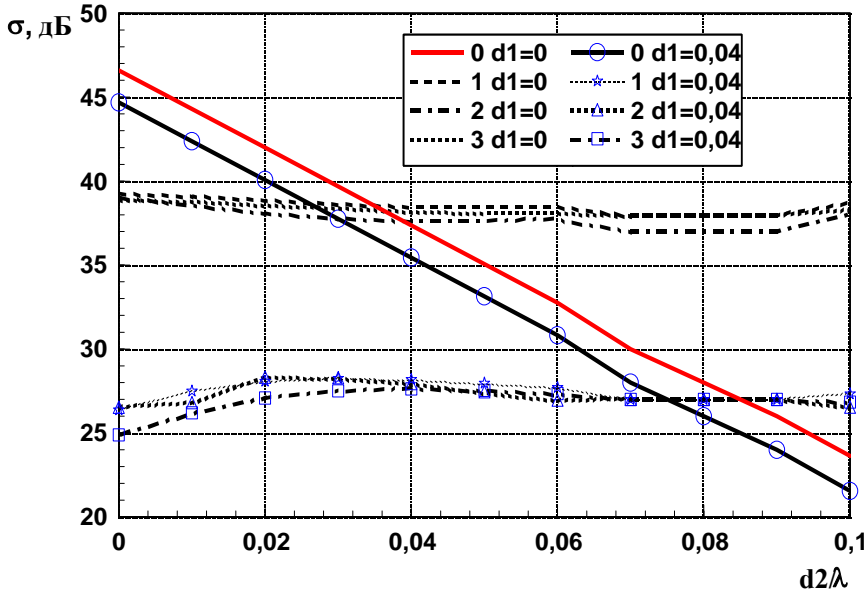

Figure 2. The dependence of RCS of cavity from the change of the thickness of a coating layer at a constant thickness of the other layer coating

Settings: $\epsilon_1 = 7,4$, $\mu_1 = 0,92 - j0,31$, and $\epsilon_2 = 13,5 - j \cdot 18,1$, $\mu_2 = 1,05$.

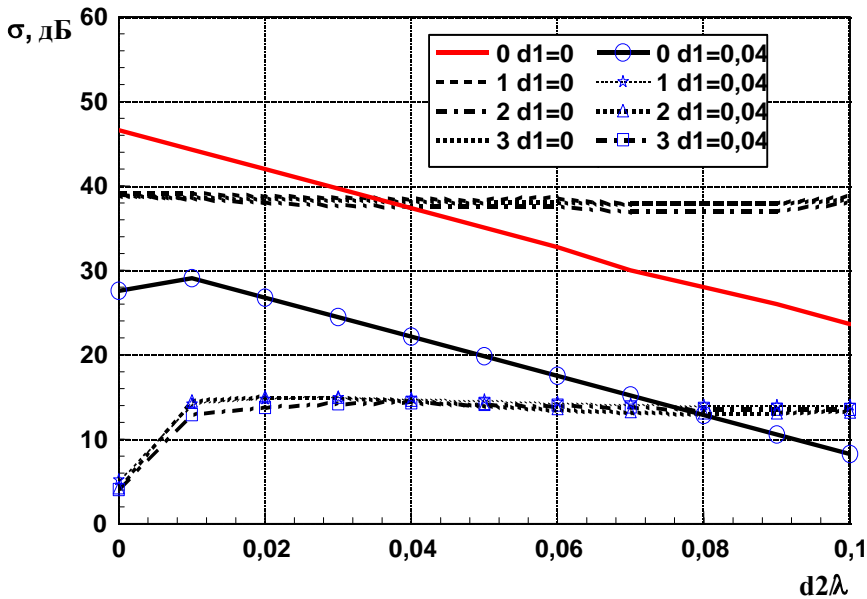

Figure 3. The dependence of RCS cavity from the change of the thickness of a coating layer at a constant thickness of the other coating layer

Parameters: $\epsilon_1=12.1 - j0,124$, $\mu_1=1,54 - j3,106$ and $\epsilon_2=13.5 - j \cdot 18,1$, $\mu_2=1.05$.

The RCS of cavity of circular cross-section is calculated as:

$$\sigma = 4\pi |S_{\theta\theta}|^2 \quad (2)$$

The scattering matrix of the cavity with radar absorbing coating is determined using the expressions for the generalized scattering matrices of the waveguide of circular cross-section of the waveguide segment and with radar absorbing coating [11].

Far field is calculated in the Kirchhoff approximation for three-dimensional case [12].

The modal calculation of the RCS cavity of a simple form of arbitrary uniform cross-section for the case of E-polarization the incident electromagnetic wave consists of the following steps [13].

1. Tangential components of electric and magnetic fields at the aperture ($z = 0$) of the cavity excited by a plane electromagnetic wave can be represented in the form of expansions in modes of waveguide with the corresponding unknown modal coefficients. At this stage, using the reciprocity theorem [126, 144], the modal coefficients are determined, within the relevant cavity modes. Calculated modal coefficients corresponding to exiting from the cavity modes, using the well-known expression for the generalized scattering matrix S_{mn} cavity.

2. In the approximation of the Stratton-Chu [279] calculated the secondary stray field of the cavity, due to coming out of the aperture modes. This approach does not take into account the diffraction of electromagnetic waves on the edges of the cavity, it can be taken into account when using the method of boundary waves [225].

3. The field scattered by the cavity is calculated based on the approximations of Stratton-Chu.

From the known values of the RCS cavity of circular cross-section can be synthesized characteristics of radio-absorbing coating, placed on the rear wall of the cavity.

A flat dummy load represents two layers of radar absorbing coating (Fig. 1). For example, as an absorbent load were examined materials $\epsilon_1 = 7,4$, $\mu_1 = 0,92 - j0,31$ and $\epsilon_2 = 13.5 - j \cdot 18,1$, $\mu_2 = 1.05$ (1st case), as well as materials with $\epsilon_1 = 12.1 - j0,124$, $\mu_1 = 1,54 - j3,106$ and $\epsilon_2 = 13.5 - j \cdot 18,1$, $\mu_2 = 1.05$ (2nd case) [281]. Consider the cavity had a radius $a = 5.5\lambda$, and length $L = 15.5\lambda$. The thickness of the layers d_1 and d_2 of radar absorbing coating is varied from 0 to 0.1λ .

It was shown that when using absorbing load in the form of two radar absorbing layers with increasing thickness one absorbing coating (d_2) with constant thicknesses of different radar absorbing coating (d_1) it is possible to achieve a significant reduction in the level of RCS in the maximum of the main lobe diagram of the inverse scattering at a constant level of RCS in the field of the first few side lobes (the change of the RCS was not more than 3 dB when changing d_2 from 0 to 0.1λ)

In Fig. 2 shows the results of calculations for the 1-st case (when $d_1 = 0$ and $d_2 = 0,04\lambda$).

In Fig. 2 marked: 0 – level of the main lobe of the diagram of return dispersion, 1, 2, 3 – level first, second and third lobe, respectively.

In Fig. 3 shows the results of calculations for the 2nd case (when $d_1 = 0$ and $d_2 = 0,045\lambda$). In Fig. 3 marked: 0 – level of the main lobe of the diagram of return dispersion, 1, 2, 3 levels first, second and third lobe, respectively.

It is possible to vary not only the thickness of the PSC, but under the given thicknesses of the radar absorbing coating to determine their dielectric or magnetic permeabil-

ity. For example, suppose that in the 2nd case the real unknown part ϵ_1 , i.e. $\epsilon_1 = X - j0,124$, $\mu_1 = 1,54 - j3,106$, where X is the unknown value.

Then asking a certain level of the main or side lobes, it is possible to determine this value. In Fig. 4.34 shows the results of calculations for this case ($d_1 = 0,055\lambda$ and $d_2 = 0,011\lambda$). In Fig. 4.34 indicated: 0-level of the main lobe of the diagram of return dispersion, 1, 2, 3 levels first, second and third lobe, respectively.

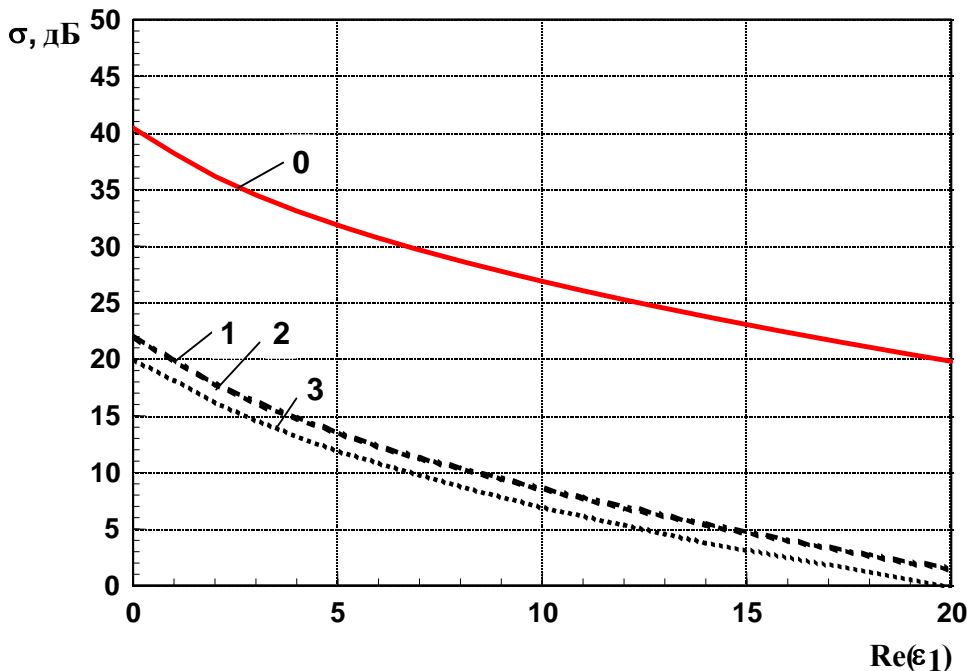

Figure 4. The determination of the real part of the dielectric the permeability of radar absorbing coatings in a given thickness of its layer

It should be noted that with the use of a modal method for modeling the characteristics of scattering of electromagnetic cavity of circular cross section terminating loads of various types. It is only necessary to know the scattering matrix of a waveguide section in which there is a given load.

Its calculation is possible, for example, on the basis of the method of integral equations or finite element method. Using the generalized scattering matrix has several advantages [14-19].

First, the scattering matrix is unique for each configuration, termination resistors and does not require recalculation for different excitations of the cavity (the angles of incidence of a plane electromagnetic wave). Secondly, in the case of symmetry of the load about the axis of symmetry of the cavity a large number of elements in the scattering matrix is equal to zero.

References

- [1] KOSZYKOWA C. Diffraction by a plane-parallel waveguide inhomogeneities with a three-layer dielectric filling. / S. Koshikava,

- T. Momoze // International electronics. The success of modern electronics, 1996. – P. 10-37.
- [2] MARKOV G. T. Mathematical Methods Applied Electromagnetics / G. Markov, E. Vasiliev. – M.: Sov. radio, 1970. – 120 p.
- [3] NOBLE D. Method of Wiener-Hopf / D. Noble. – M.: Publishing House of Foreign. lit-ry, 1962. – 279 p.
- [4] KNOTT YF Development of methods of calculation of the effective area of the reflection of radar targets // Proc, 1985. – V. 73. – № 2. – P. 90-105.
- [5] BURKHOLDER R. J. High-frequency asymptotic methods for analyzing the EM scattering by open-ended waveguide cavities / R. J. Burkholder – Ph.D. dissertation, The Ohio State University, Columbus, OH, 1989.
- [6] PATHAK P. H. Modal, ray and beam techniques for analysing the EM scattering by open-ended waveguide cavities / P. H. Pathak, R. J. Burkholder // IEEE Trans. Antennas Propagat., 1989, vol. AP-37, № 5. – P. 635-647.
- [7] ALTINTAS A. A selective modal scheme for the analysis of EM coupling into or radiation from large open-ended waveguides. / A. Altintas, P. H. Pathak, M. C. Liang // IEEE Trans. Antennas Propagat, 1988. – Vol. AP-36. – No. 1. – P. 84-96.
- [8] SAZONOV, D. M. Microwave Devices / D. M. Sazonov, A. N. Gridin, B. A. Mishustin. – M: Executive. School, 1981. – 295 p.
- [9] ALHOVSKY E. A. Flexible waveguides in the art of microwave / E. A. Alhovskiy, G. S. Golovchenko, Il'inskii etc. – M.: Radio and Communications, 1986.
- [10] LING H. High-frequency RCS of open cavities with rectangular and circular cross sections. / H. Ling, S. W. Lee, R. C. Chou // IEEE Trans. Antennas Propagat., 1989, vol. AP-37, № 5. – P. 648-654.
- [11] NICHOLAS V. Electrodynamics and Propagation / V. V. Nikolsky. – M.: Nauka, 1978. – 543 p.
- [12] Numerical methods in electrodynamics / Ed. R. Mitra. – M.: Mir, 1977. – 485 p.
- [13] LING H. RCS of waveguide cavities: a hybrid boundary-integral / Modal approach / H. Ling // IEEE Trans. Antennas Propagat., 1990, vol. AP-38, no. 9. – p. 1413-1420.
- [14] MISHIN J. A. About the computer-aided design systems in wireless networks / Y. A. Mishin // Herald of the Voronezh Institute of High Technologies. 2013. – № 10. – p. 153-156.
- [15] MILOSHENKO O. V. Methods for evaluating propagation characteristics in mobile radio communication systems / O. V. Miloshenko // Herald of the Voronezh Institute of High Technologies. – 2012. – № 9. – P. 60-62.
- [16] GOLOVINOV S. O. Management problems of mobile communication systems / S. O. Golovinov, A. A. Hromyh // Herald of the Voronezh Institute of High Technologies. – 2012. – № 9. – P. 13-14.
- [17] LVOVICH I. J. Application of methodological analysis in the safety

- study / I. Ya. Lvovich, A. A. Voronov // Information and Security. 2011. – T. 14. – № 3. – S. 469-470.
- [18] ERASOV S. V. Optimising processes in the electrodynamic problems / S. V. Erasov // Herald of the Voronezh Institute of High Technologies. – 2013. – № 10. – P. 20-26.
- [19] BOLUCHEVSKAYA O. A. The properties of the scattering characteristics of the evaluation methods of electromagnetic waves / O. A. Boluchevskaya, O. N. Gorbenko // Simulation, optimization and information technology. – 2013. – № 3. – P. 4.

Prof. Yakov Lvovich, D. Sc.

the honored scientist of the Russian Academy of Natural Sciences
President of Voronezh Institute of High Technologies
office@vivt.ru

Doc. Andrew Preobrazhensky

Voronezh Institute of High Technologies
app@vivt.ru

Prof. Oleg Choporov, D. Sc.

Voronezh Institute of High Technologies
Choporov_oleg@mail.ru



Model decision rules to detect anomalies in Information Systems

B. Akhmetov, A. Korchenko, N. Zhumangalieva, J. Kultan

Abstract:

The disadvantage of modern intrusion detection systems, built on the principle of identifying the abnormal condition is that they are mainly focused on the use of mathematical models that require a lot of time to prepare statistics. Mathematical models based on expert approaches in this regard are more effective, but for the performance of its functions require the use of appropriate decision rules. For solving this problem, we propose a model of decision rules on fuzzy logic, which through the use of a plurality of pairs of "invasion: the value" and "Invasion: the set of conjugate pairs", as well as models of reference values allows you to display an abnormal condition, generates a certain type of cyber attack in computer network. Based on this model there have been developed examples of rules to detect such intrusions as scanning, spoofing and Dos-attacks that can practically be used to improve real systems intrusion detection mechanism is used to identify anomalies generated by the actions of attacking computer systems.

Key words:

Cyber attack, intrusion detection systems, network traffic anomaly, anomaly detection in computer systems, the set of conjugate pairs, decision rules, expert evaluation

ACM Computing Classification System:

Combinatorial algorithms, Algebraic algorithms, Nonalgebraic algorithms, Symbolic calculus algorithms, Exact arithmetic algorithms, Hybrid symbolic-numeric methods.

■ Введение

Стремительное развитие информационных технологий (ИТ) в свою очередь породило большое количество угроз ресурсам информационных систем (РИС). Одним из решений обеспечения безопасности РИС, являются системы обнаружения вторжений (СОВ) представляющие собой программные или аппаратные средства, ориентированные прежде всего на выявление фактов неавторизованного доступа. Следует отметить, что современные СОВ основываются на сигнатурном (шаблонном) и аномальном принципах.

Первый базируется на представлении каждого вторжения в виде определенного шаблона (модели, сценария, правила, сигнатуры) отражающего характеристики и сценарии возможных несанкционированных воздействий. Поэтому такие системы с достаточно высокой точностью выявляют тип кибератак и практически функционируют без ложных срабатываний. Анализ сетевого трафика с использованием сигнатурного принципа характерен тем, что распознавание возможно только при известных кибератаках, а для этого необходимо постоянно обновлять и расширять наборы шаблонов. Кроме неустойчивости к новейшим типам вторжений, такие системы сильно зависят от скорости разработки и обновления сигнатур. Также известно, что например, для таких вторжений как сложные распределенные атаки проверка известных шаблонов является достаточно сложной задачей.

Второй принцип основан на выявлении аномального состояния системы порожденного кибератакой и ориентирован на контроль активности в среде окружения, например, наблюдение за значениями величин сетевого трафика. Преимущества систем, реализующих этот принцип, в первую очередь связано с тем, что они могут обнаруживать не только новые виды кибератак, но и те, которые характеризуются большой продолжительностью во времени.

■ 1. Описание отдельных методов

Существующие СОВ аномального принципа в основном ориентированы на использование таких математических моделей, которые требуют много времени на подготовку статистических данных, что не требуют более эффективные в этом отношении экспертные подходы, преимущества которых показаны в (Корченко 2006). В связи с этим актуальной задачей при разработке СОВ является создание моделей обнаружения аномалий на основе экспертных оценок. В работе (Ахметов, Корченко, Жумангалеева 2016) предложена модель базовых величин (МБВ), которая за счет множества пар «вторжение : величины» и «вторжение : множество сопряженных пар» позволяют отображать аномальное состояние, порождаемое определенным типом вторжения в компьютерной сети. Также, известна модель эталонных величин (МЭВ) (Ахметов, Корченко, Жумангалеева 2015), которая за счет данных экспертных оценок и МБВ позволяет формировать множества эталонных величин характерных для определенного типа вторжения.

Применение этих моделей при построении СОВ, базирующихся на втором принципе, связано с необходимостью формирования правил, направленных на выявления аномального состояния порожденного атакующими действиями. В связи с этим, целью данной работы является разработка математической модели

используемой при формировании соответствующих решающих правил для идентификации аномального состояния в среде окружения. Под средой окружения будем подразумевать совокупность значений сформированных переменных (например, время обработки запроса, загруженность процессора, количество обращений к ресурсу, число подключений и др.), которые можно использовать для оценивания протекающих процессов в информационной системе (ИС) с целью выявления ее аномального состояния. Отображением среды окружения в данном случае могут быть величины входящие в множество V (Ахметов, Корченко, Жумангалеева 2016). Для решения поставленной задачи необходимо построить решающие правила, представляющие собой некоторые утверждения, основанные на результате обобщения определенных теоретических и экспериментальных знаний (данных) и отражающие интуитивное суждение лица, принимающего решение, для обеспечения поиска рационального смыслового решения слабо формализованных задач.

2. Математические определения

Построение решающих правил можно осуществить с помощью соответствующей модели, для создания которой введем множество нечетких идентификаторов (fuzzy identifiers)

$$FI = \bigcup_{i=1}^d FI_i = \{FI_1, FI_2, FI_3, \dots, FI_d\}, (i = \overline{1, d}), \quad (1)$$

где d – количество элементов множества, необходимое для отображения аномального состояния, а FI_i ($i = \overline{1, d}$) – элементы FI , каждый из которых принимает одно из текстовых значений, характеризующих в нечеткой форме уровень аномального состояния системы, которое может быть порождено определенными вторжениями. Например, при $d=5$ выражение (1) можно определить как:

$$FI = \bigcup_{i=1}^5 FI_i = \{FI_1, FI_2, FI_3, FI_4, FI_5\} = \{L, LTH, HTTL, H, LIM\}, \quad (2)$$

где $FI_1=L$, $FI_2=LTH$, $FI_3=HTTL$, $FI_4=H$ и $FI_5=LIM$ соответственно отображаются текстовыми значениями

- «Low (L)» – «Низкий»,
- «Lower than high (LTH)» – «Больше низкий чем высокий»,
- «Higher than the lowest (HTTL)» – «Больше высокий чем низкий»,
- «High (H)» – «Высокий»,
- «Limits (LIM)» – «Предельный».

Далее на основе множеств нечетких идентификаторов FI и сопряженных пар MP [2] построим множество решающих правил (solution rule)

$$SR = \left\{ \bigcup_{i=1}^n SR_i \right\} = \{SR_1, SR_2, SR_3, \dots, SR_n\}, (i = \overline{1, n}), \quad (3)$$

где SR_i – подмножество возможных правил для выявления i -го аномального состояния, порожденного i -м вторжением, при этом

$$\bigcup_{i=1}^n \mathbf{SR}_i = \bigcup_{i=1}^n \left\{ \bigcup_{j=1}^{r_i} SR_{ij} \right\} = \{SR_{11}, SR_{12}, SR_{13}, \dots, SR_{1r_1}\},$$

$$\{SR_{21}, SR_{22}, SR_{23}, \dots, SR_{2r_2}\}, \{SR_{31}, SR_{32}, SR_{33}, \dots, SR_{3r_3}\}, \dots,$$

$$\{SR_{n1}, SR_{n2}, SR_{n3}, \dots, SR_{nr_n}\}, (i = \overline{1, n}, j = \overline{1, r_i}), \quad (4)$$

где SR_{ij} – j -е правило i -го подмножества возможных правил, а r_i ($i = \overline{1, n}$) – общее количество возможных правил, направленных на обнаружение i -й аномалии.

Отметим, что каждому SR_{ij} соответствует решающее выражение (правило) т. е.:

$$\left\{ \begin{array}{l} SR_{11} = (MP_{11} \in FI_{11}), \\ SR_{21} = (MP_{21} \in FI_{21}), \\ SR_{31} = (MP_{31} \in FI_{31}), \\ \dots \\ SR_{n1} = (MP_{n1} \in FI_{n1}), \end{array} \right. \left\{ \begin{array}{l} SR_{12} = (MP_{12} \in FI_{12}), \\ SR_{22} = (MP_{22} \in FI_{22}), \\ SR_{32} = (MP_{32} \in FI_{32}), \\ \dots \\ SR_{n2} = (MP_{n2} \in FI_{n2}), \end{array} \right. \left\{ \begin{array}{l} SR_{13} = (MP_{13} \in FI_{13}), \\ SR_{23} = (MP_{23} \in FI_{23}), \\ SR_{33} = (MP_{33} \in FI_{33}), \\ \dots \\ SR_{n3} = (MP_{n3} \in FI_{n3}), \end{array} \right. \left\{ \begin{array}{l} SR_{1r_1} = (MP_{1r_1} \in FI_{1r_1}), \\ SR_{2r_2} = (MP_{2r_2} \in FI_{2r_2}), \\ SR_{3r_3} = (MP_{3r_3} \in FI_{3r_3}), \\ \dots \\ SR_{nr_n} = (MP_{nr_n} \in FI_{nr_n}), \end{array} \right. \quad (5)$$

Обобщая выражение (5) с учетом (3) и (4) получим

$$\mathbf{SR} = \bigcup_{i=1}^n \left\{ \bigcup_{j=1}^{r_i} SR_{ij} \right\} = \bigcup_{i=1}^n \left\{ \bigcup_{j=1}^{r_i} (MP_{ir_j} \in FI_{ir_j}) \right\} =$$

$$\left\{ \bigcup_{i=1}^n \left\{ \bigcup_{j=1}^{r_i} SR_{ij} = (MP_{ir_j} \in FI_{ir_j}) \right\} \right\}, (i = \overline{1, n}, j = \overline{1, r_i}), \quad (6)$$

где SR_{ir_j} есть r_j -е правило выявления аномалии порожденной i -м вторжением, которое буквально интерпретируется как: «Если MP_{ir_j} истинно, то уровень аномального состояния, который может быть порожден i -м вторжением, будет FI_{ir_j} ».

Построение правил обычно осуществляется на основе экспертного подхода, особенно это важно в тех случаях, когда необходимо дать предпочтение одной из альтернатив, например, при каком MP_{ir_j} (6) исход, связанный с FI_{ir_j} будет наиболее объективно отображать состояние системы. Рассмотрим процесс формирования предпочтения для набора альтернатив на конкретном примере.

Пусть для построения подмножества правил \mathbf{SR}_1 используется r_1 сопряженных пар и d (1) нечетких идентификаторов, один из которых наиболее объективно может отразить состояние среды окружения относительно наличия

аномалии. Итак, общее количество возможных альтернативных решений – $d \times r_1$, т. е. на составление каждого правила SR_{1j} ($j = \overline{1, r_1}$) необходимо рассмотреть d альтернативных вариантов правил, для выбора одного из которых воспользуемся методами определения коэффициентов важности (КВ) [4]. Воспользуемся методом ранговых преобразований (РП), поскольку он позволяет воспользоваться услугами нескольких экспертов, в качестве входных данных применяются табличные формы, выходная функция линейная, а трудоемкость низкая (Ахметов, Корченко, Ахметова, Жумангалеева 2014).

Далее, в качестве примера, определим $d=r_1=5$, тогда

$$MP_{1j} = \left\{ \bigcup_{j=1}^{r_1} MP_{1j} \right\} = \{MP_{11}, MP_{12}, MP_{13}, MP_{14}, MP_{15}\} =$$

$$\{((\underline{t}_{SPR} \cong \underline{L}^e \vee \underline{t}_{DBR} \cong \underline{S}^e) \wedge \underline{t}_{NCC} \cong \underline{VS}^e), ((\underline{t}_{SPR} \cong \underline{L}^e \vee \underline{t}_{DBR} \cong \underline{S}^e) \wedge$$

$$\underline{t}_{NCC} \cong \underline{S}^e),$$

$$((\underline{t}_{SPR} \cong \underline{L}^e \vee \underline{t}_{DBR} \cong \underline{S}^e) \wedge \underline{t}_{NCC} \cong \underline{A}^e),$$

$$((\underline{t}_{SPR} \cong \underline{L}^e \vee \underline{t}_{DBR} \cong \underline{S}^e) \wedge \underline{t}_{NCC} \cong \underline{B}^e),$$

$$((\underline{t}_{SPR} \cong \underline{L}^e \vee \underline{t}_{DBR} \cong \underline{S}^e) \wedge \underline{t}_{NCC} \cong \underline{VB}^e)\}, \quad (6a)$$

а в качестве значений FI_{1j} ($j = \overline{1, 5}$) воспользуемся данными из формулы (2).

Таким образом, для каждого MP_{1j} ($j = \overline{1, 5}$) возможны $d=5$ исходов выявления аномалий, связанных с конкретными значениями нечетких идентификаторов в (2). Наиболее объективный из исходов определим с помощью метода средних рангов (СР) (Ахметов, Корченко, Ахметова, Жумангалеева 2014).

Таблица 1. Ранги SR_{1j}^k и КВ

SR_{1j}^k	j	k	Эксперт ы				x_{1j}^k	λ_{1j}^k
			1	2	3	4		
SR_{11}^1	1	1	1	3	1	2	1,75	0,18
SR_{11}^2		2	2	1	3	2	2	0,2
SR_{11}^3		3	3	2	2	2	2,25	0,23
SR_{11}^4		4	2	4	3	3	3	0,3
SR_{11}^5		5	4	4	3	4	3,75	0,38
SR_{12}^1	2	1	2	3	1	2	2	0,2
SR_{12}^2		2	1	2	1	2	1,5	0,15

SR_{12}^3		3	3	1	2	3	2,25	0,23
SR_{12}^4		4	3	4	2	2	2,75	0,28
SR_{12}^5		5	3	2	3	4	3	0,3
SR_{13}^1	3	1	2	3	2	4	2,75	0,28
SR_{13}^2		2	3	2	2	1	2	0,2
SR_{13}^3		3	2	3	1	1	1,75	0,18
SR_{13}^4		4	3	4	3	4	3,5	0,35
SR_{13}^5		5	4	3	2	4	3,25	0,33
SR_{14}^1	4	1	4	2	2	4	3	0,3
SR_{14}^2		2	2	4	3	2	2,75	0,28
SR_{14}^3		3	3	1	2	2	2	0,2
SR_{14}^4		4	1	2	3	1	1,75	0,18
SR_{14}^5		5	2	4	4	3	3,25	0,33
SR_{15}^1	5	1	4	4	3	3	3,5	0,35
SR_{15}^2		2	2	4	4	3	3,25	0,33
SR_{15}^3		3	2	4	3	3	3	0,3
SR_{15}^4		4	4	3	2	3	3	0,3
SR_{15}^5		5	2	2	4	3	2,75	0,28

Согласно этого метода, в качестве примера, воспользуемся суждениями 4-х экспертов относительно $d=5$ возможных исходов SR_{ij}^k ($k = \overline{1, d}$, $j = \overline{1, r_1}$) по каждому j -му правилу. Например, для первого правила подмножество альтернативных решений будет

$$\begin{aligned}
 \bigcup_{k=1}^d SR_{11}^k &= \{SR_{11}^1, SR_{11}^2, SR_{11}^3, SR_{11}^4, SR_{11}^5\} = \\
 &\{((\underline{t}_{SPR} \cong \underline{L}^e \vee \underline{t}_{DBR} \cong \underline{S}^e) \wedge \underline{t}_{NCC} \cong \underline{VS}^e) \in L, \\
 &((\underline{t}_{SPR} \cong \underline{L}^e \vee \underline{t}_{DBR} \cong \underline{S}^e) \wedge \underline{t}_{NCC} \cong \underline{S}^e) \in LTH, \\
 &((\underline{t}_{SPR} \cong \underline{L}^e \vee \underline{t}_{DBR} \cong \underline{S}^e) \wedge \underline{t}_{NCC} \cong \underline{A}^e) \in HTTL, \quad (6 \text{ b})
 \end{aligned}$$

$$((\underline{t}_{SPR} \cong \underline{L}^e \vee \underline{t}_{DBR} \cong \underline{S}^e) \wedge \underline{t}_{NCC} \cong \underline{B}^e) \in H,$$

$$((\underline{t}_{SPR} \cong \underline{L}^e \vee \underline{t}_{DBR} \cong \underline{S}^e) \wedge \underline{t}_{NCC} \cong \underline{VB}^e) \in LIM \}.$$

Далее на основе РП определим KB, которые отражаются величиной λ . Его минимальное значение свидетельствует о большей предпочтительности альтернативы, т. е. ее KB более высокий. Для правила SR_{11} произведем расчеты значений x_{1j}^k и λ_{1j}^k по каждому из возможных исходов SR_{11}^k ($k = \overline{1,5}$):
 $x_{11}^1 = (1+3+1+2)/4 = 1,75$; $x_{11}^2 = (2+1+3+2)/4 = 2$; $x_{11}^3 = (3+2+2+2)/4 = 2,25$;
 $x_{11}^4 = (2+4+3+3)/4 = 3$; $x_{11}^5 = (4+4+3+4)/4 = 3,75$. Значение KB определяется как $\lambda_{1j}^k = x_{1j}^k / N$, где N – сумма всех рангов ($N=10$). По результатам, занесенным в табл. 1 видно, что лучший исход имеет, SR_{11}^1 поскольку $\bigwedge_{k=1}^5 \lambda_{11}^k = \lambda_{11}^1 = 0,18$.

Аналогично произведем расчеты для

$$\begin{aligned} SR_{1j}^k \ (j = \overline{2,5}): \quad & SR_{12}^k - x_{12}^1 = (2+3+1+2)/4 = 2; \quad x_{12}^2 = (1+2+1+2)/4 = 1,5; \\ & x_{12}^3 = (3+1+2+3)/4 = 2,25; \quad x_{12}^4 = (3+4+2+2)/4 = 2,75; \quad x_{12}^5 = (3+2+3+4)/4 = 3; \quad SR_{13}^k - \\ & x_{13}^1 = (2+3+2+4)/4 = 2,75; \quad x_{13}^2 = (3+2+2+1)/4 = 2; \quad x_{13}^3 = (2+3+1+1)/4 = 1,75; \\ & x_{13}^4 = (3+4+3+4)/4 = 3,5; \quad x_{13}^5 = (4+3+2+4)/4 = 3,25; \quad SR_{14}^k - x_{14}^1 = (4+2+2+4)/4 = 3; \\ & x_{14}^2 = (2+4+3+2)/4 = 2,75; \quad x_{14}^3 = (3+1+2+2)/4 = 2; \quad x_{14}^4 = (1+2+3+1)/4 = 1,75; \\ & x_{14}^5 = (2+4+4+3)/4 = 3,25; \quad SR_{15}^k - x_{15}^1 = (4+4+3+3)/4 = 3,5; \quad x_{15}^2 = (2+4+4+3)/4 = 3,25; \\ & x_{15}^3 = (2+4+3+3)/4 = 3; \quad x_{15}^4 = (4+3+2+3)/4 = 3; \quad x_{15}^5 = (2+2+4+3)/4 = 2,75. \end{aligned} \quad (6\ c)$$

По результатам вычислений (см. табл. 1) видно, что лучший исход для правил SR_{12} , SR_{13} , SR_{14} , SR_{15} имеют соответственно альтернативные варианты SR_{12}^2 , SR_{13}^3 , SR_{14}^4 , SR_{15}^5 .

Полученные данные можно использовать в качестве конкретных значений при построении реальных правил в практических СОВ. С этой целью, с учетом (6), осуществим структурирование необходимых данных путем ввода матриц инициализации (МИ) для множеств **FI** и **MP**, которые обозначим соответственно $FI(n, r_n)$ и $MP(n, r_n)$, т. е.

$$FI(n, r_n) = \begin{vmatrix} FI(1, 1), & FI(1, 2), & FI(1, 3), & \dots, & FI(1, r_n) \\ FI(2, 1), & FI(2, 2), & FI(2, 3), & \dots, & FI(2, r_n) \\ FI(3, 1), & FI(3, 2), & FI(3, 3), & \dots, & FI(3, r_n) \\ \dots & \dots & \dots & \dots & \dots \\ FI(n, 1), & FI(n, 2), & FI(n, 3), & \dots, & FI(n, r_n) \end{vmatrix} \mu$$

$$MP(n, r_n) = \begin{vmatrix} MP(1, 1), & MP(1, 2), & MP(1, 3), & \dots, & MP(1, r_n) \\ MP(2, 1), & MP(2, 2), & MP(2, 3), & \dots, & MP(2, r_n) \\ MP(3, 1), & MP(3, 2), & MP(3, 3), & \dots, & MP(3, r_n) \\ \dots & \dots & \dots & \dots & \dots \\ MP(n, 1), & MP(n, 2), & MP(n, 3), & \dots, & MP(n, r_n) \end{vmatrix}. \quad (7)$$

Например, при $n=3$ и $r_n=5$ на основе экспертных оценок [4] были определены следующие MI $FI(3, 5)$ и $MP(3, 5)$, т. е.

$$\begin{array}{l}
 \begin{array}{cccccc}
 & LOW & LTH & HTTL & H & LIM \\
 FI(3, 5)= & LOW & LOW & HTTL & H & LIM & H \\
 & LOW & LTH & HTTL & H & H &
 \end{array} \\
 (\underline{t}_{SPR} \cong \underline{L}^e \vee (\underline{t}_{SPR} \cong \underline{L}^e \vee (\underline{t}_{SPR} \cong \underline{L}^e \vee (\underline{t}_{SPR} \cong \underline{L}^e \vee (\underline{t}_{SPR} \cong \underline{L}^e \vee \\
 \underline{t}_{DBR} \cong \underline{S}^e) \wedge \underline{t}_{DBR} \cong \underline{S}^e) \wedge \underline{t}_{DBR} \cong \underline{S}^e) \wedge \underline{t}_{DBR} \cong \underline{S}^e) \wedge \underline{t}_{DBR} \cong \underline{S}^e) \wedge \\
 \underline{t}_{NCC} \cong \underline{VS}^e \quad \underline{t}_{NCC} \cong \underline{S}^e \quad \underline{t}_{NCC} \cong \underline{A}^e \quad \underline{t}_{NCC} \cong \underline{B}^e \quad \underline{t}_{NCC} \cong \underline{VB}^e \\
 MP(3, 5)= \underline{t}_{NPSA} \cong \underline{B}^e \wedge \underline{t}_{NPSA} \cong \underline{B}^e \wedge \underline{t}_{NPSA} \cong \underline{B}^e \wedge \underline{t}_{NPSA} \cong \underline{B}^e \wedge \underline{t}_{NPSA} \cong \underline{B}^e \wedge \\
 \underline{t}_{NCC} \cong \underline{VS}^e \quad \underline{t}_{NCC} \cong \underline{S}^e \quad \underline{t}_{NCC} \cong \underline{A}^e \quad \underline{t}_{NCC} \cong \underline{B}^e \quad \underline{t}_{NCC} \cong \underline{VB}^e \\
 \underline{t}_{VCA} \cong \underline{S}^e \wedge \underline{t}_{VCA} \cong \underline{S}^e \wedge \underline{t}_{VCA} \cong \underline{S}^e \wedge \underline{t}_{VCA} \cong \underline{S}^e \wedge \underline{t}_{VCA} \cong \underline{S}^e \wedge \\
 \underline{t}_{NVC} \cong \underline{VS}^e \quad \underline{t}_{NVC} \cong \underline{S}^e \quad \underline{t}_{NVC} \cong \underline{A}^e \quad \underline{t}_{NVC} \cong \underline{B}^e \quad \underline{t}_{NVC} \cong \underline{VB}^e)
 \end{array}$$

(8)

где \underline{t}_{NCC} , \underline{t}_{SPR} , \underline{t}_{DBR} , \underline{t}_{NPSA} , \underline{t}_{VCA} , \underline{t}_{NVC} – текущие значения величин

«Number of concurrent connections to the server (NCC)» – «Количество одновременных подключений к серверу», «Speed of processing requests from the clients (SPR)» – «Скорость обработки запросов от клиентов», «The delay between requests from the single user (DBR)» – «Задержка между запросами от одного пользователя», «Number of packages with the same sender and receiver address ($NPSA$)» – «Количество пакетов с одинаковым адресом отправителя и получателя», «Virtual Channel Age (VCA)» – «Возраст виртуального канала», «Numbers of Virtual channels (NVC)» – «Количество виртуальных каналов» и являются идентификаторами величин [2] в среде окружения. Используемый в (8) знак « \cong » – интерпретируется как «Нечеткое равно» и указывает на то, что текущее значение величины (например, \underline{t}_{SPR}) находящегося слева от « \cong » наиболее близко к одному из элементов

(например, \underline{L}^e) из заданного множества (например, $T_{SPR}^e = \{ \underline{L}^e, \underline{A}^e, \underline{H}^e \}$), который

указывается справа от « \cong », т. е. запись $\underline{t}_{SPR} \cong \underline{L}^e$ можно интерпретировать как:

« \underline{t}_{SPR} наиболее близко расположен к \underline{L}^e входящего в T_{SPR}^e ».

Далее с учетом МІ (при $i=1, j=\overline{1,5}$) для $FI(n, r_n)$ и $MP(n, r_n)$ на основе (7) и (8) построим подмножество правил SR_I для выявления аномального состояния, которое может быть порождено таким вторжением, как Dos (DDos) атака.

$$SR_I = \left\{ \begin{array}{l} SR_{I1} = ((\underline{t}_{SPR} \cong \underline{L}^e \vee \underline{t}_{DBR} \cong \underline{S}^e) \wedge \underline{t}_{NCC} \cong \underline{VS}^e) \in L, \\ SR_{I2} = ((\underline{t}_{SPR} \cong \underline{L}^e \vee \underline{t}_{DBR} \cong \underline{S}^e) \wedge \underline{t}_{NCC} \cong \underline{S}^e) \in LTH, \\ SR_{I3} = ((\underline{t}_{SPR} \cong \underline{L}^e \vee \underline{t}_{DBR} \cong \underline{S}^e) \wedge \underline{t}_{NCC} \cong \underline{A}^e) \in HTTL, \\ SR_{I4} = ((\underline{t}_{SPR} \cong \underline{L}^e \vee \underline{t}_{DBR} \cong \underline{S}^e) \wedge \underline{t}_{NCC} \cong \underline{B}^e) \in H, \\ SR_{I5} = ((\underline{t}_{SPR} \cong \underline{L}^e \vee \underline{t}_{DBR} \cong \underline{S}^e) \wedge \underline{t}_{NCC} \cong \underline{VB}^e) \in LIM. \end{array} \right. \quad (9)$$

Отметим, что правило SR_{I5} в (9) буквально можно интерпретировать как: «Если $\underline{t}_{SPR} \cong \underline{L}^e$ или $\underline{t}_{DBR} \cong \underline{S}^e$ и при этом $\underline{t}_{NCC} \cong \underline{VB}^e$, то уровень аномального состояния, который может быть порожден Dos-атакой, будет LIM (Предельный)».

Из подмножества правил (9) видно, что для каждой сопряженной пары из SR_{Ij} ($j=\overline{1,5}$) определены конкретные значения из FI согласно расчетов КВ с помощью метода РП. Используя эти данные по аналогии можно составить правила для выявления аномалий порожденных спуфингом и сканированием [2, 3]. Так с учетом (7) и (8) при $i=\overline{2,3}$ и $j=\overline{1,5}$ наборы правил SR_2 (10) и SR_3 (11) будут иметь следующий вид:

$$SR_2 = \{ SR_{21} = (\underline{t}_{NPSA} \cong \underline{B}^e \wedge \underline{t}_{NCC} \cong \underline{VS}^e) \in L, \\ SR_{22} = (\underline{t}_{NPSA} \cong \underline{B}^e \wedge \underline{t}_{NCC} \cong \underline{S}^e) \in LTH, \\ SR_{23} = (\underline{t}_{NPSA} \cong \underline{B}^e \wedge \underline{t}_{NCC} \cong \underline{A}^e) \in HTTL, \quad (10)$$

$$SR_{24} = (\underline{t}_{NPSA} \cong \underline{B}^e \wedge \underline{t}_{NCC} \cong \underline{B}^e) \in H, \\ SR_{25} = (\underline{t}_{NPSA} \cong \underline{B}^e \wedge \underline{t}_{NCC} \cong \underline{VB}^e) \in LIM \} \text{ и}$$

$$SR_3 = \{ SR_{31} = (\underline{t}_{VCA} \cong \underline{S}^e \wedge \underline{t}_{NVC} \cong \underline{VS}^e) \in L, \\ SR_{32} = (\underline{t}_{VCA} \cong \underline{S}^e \wedge \underline{t}_{NVC} \cong \underline{S}^e) \in LTH, \quad (11)$$

$$SR_{33} = (\underline{t}_{VCA} \cong \underline{S}^e \wedge \underline{t}_{NVC} \cong \underline{A}^e) \in HTTL,$$

$$SR_{34} = (\underline{t}_{VCA} \cong \underline{S}^e \wedge \underline{t}_{NVC} \cong \underline{B}^e) \in H,$$

$$SR_{35} = (\underline{t}_{VCA} \cong \underline{S}^e \wedge \underline{t}_{NVC} \cong \underline{VB}^e) \in LIM \}.$$

► Заключение

Предложенная в работе модель решающих правил на нечеткой логике, позволяет за счет использования множества пар «вторжение : величины», «вторжение : множество сопряженных пар» и МЭВ отображать аномальное состояние, порождаемое определенным типом кибератак в компьютерной сети. На основе этой модели были разработаны примеры правил для обнаружения таких вторжений как сканирование, спуфинг и Dos-атака, которые могут практически быть использованы для усовершенствования реальных систем обнаружения вторжений применяющих механизмы выявления аномалий, порожденных атакующими действиями в компьютерных системах.

► Литература

- [1] Корченко, Г. 2006. Построение систем защиты информации на нечетких множествах [Текст]: Теория и практические решения: МК-Пресс, 2006. 320 р.
- [2] Ахметов Б.С., Корченко А.А., Жумангалиева Н.К. 2016 Модель базовых величин для контроля аномальности состояния среды окружения In: Вестник НАН РК. 2016. п. 1.
- [3] Ахметов Б.С., Корченко А.А., Жумангалиева Н.К. 2015 - Базовые модели эталонных величин для систем обнаружения вторжений / Вестник МКТУ Х.А.Ясави . 2015. п. 4.
- [4] Ахметов, Корченко, Ахметова, Жумангалеева. 2014. Использование методов экспертного оценивания в системах обнаружения вторжений In: Информационна безпека. 2014. п. 3 (15); п. 4 (16). р. 34-43.

Модель решающих правил для обнаружения аномалий в информационных системах

Аннотация:

Недостатком современных систем обнаружения вторжений, построенных на принципе идентификации аномального состояния является то, что они в основном ориентированы на использование таких математических моделей, которые требуют много времени на подготовку статистических данных. Математические модели, основанные на экспертных подходах в этом отношении являются более эффективными, но для выполнения своих функций необходимо использование соответствующих решающих правил. Для решения этой задачи в работе предложена модель решающих правил на нечеткой

логике, которая за счет использования множества пар «вторжение : величины» и «вторжение : множество сопряженных пар», а также модели эталонных величин позволяет отображать аномальное состояние, порождаемое определенным типом кибератак в компьютерной сети. На основе этой модели были разработаны примеры правил для обнаружения таких вторжений как сканирование, спуфинг и Dos-атака, которые могут практически использоваться для усовершенствования реальных систем выявления вторжений применяющих механизмы выявления аномалий, порожденных атакующими действиями в компьютерных системах.

Ключевые слова:

Кибератака, системы обнаружения вторжений, аномалия в сетевом трафике, обнаружение аномалий в компьютерных системах, сопряженная пара, решающие правила, экспертная оценка.

Ахметов Бахытжан Сражатдинович, д. т. н., проф.
КазНИТУ им. К. И. Сатпаева bakhytzhana.akhmetov.54@mail.ru

Корченко Анна Александровна к. т. н., доц.
Национальный авиационный университет Украина г. Киев annakor@ukr.net

Жумангалиева Назым Кенжегалиевна, магистр
КазНИТУ им. К. И. Сатпаева
nazym_k.81@mail.ru

Dr. Ing. Jaroslav Kultan, PhD.
Ekonomická univerzita v Bratislave
Fakulta hospodárskej informatiky
jkultan@gmail.com



Automation of the distribution process of sensitive data processing in a hybrid cloud computing environment

Anatoly Tsaregorodtsev, Anna Zelenina

Abstract:

Use of cloud computing applications and services requires review and adaptation of existing formal models for informational telecommunication systems security. It is necessary to consider the benefits of cloud deployment models and provide the procedure for allocating process among components of cloud computing environment for achieving confidentiality and data protection.

Key words:

Security model of informational telecommunication systems, cloud computing, public cloud, private cloud, hybrid cloud, security requirements, theory of graphs, data confidentiality.

ACM Computing Classification System:

Distributed architectures, Cloud computing, Distributed systems organizing principles, Cloud based storage, Information flow control, Security requirements, Formal security models, Distributed systems security.

▲ Введение

Принимая во внимание парадигму облачных вычислений, организация отказывается от прямого контроля над многими аспектами безопасности и, тем самым, создаёт беспрецедентный уровень доверия облачному провайдеру [1]. Преимущества облачных вычислений могут позволить существенно сократить сроки и издержки на разработку систем для федеральных агентств и государственных организаций. Особую актуальность принимает гибридная модель развёртывания облачных сервисов, которая подразумевает обработку критичных данных в частной среде облачных вычислений, которая находится под полным контролем организации. Но многие из функций, которые делают привлекательными облачные вычисления, могут вступать

в противоречие с традиционными моделями обеспечения информационной безопасности. При анализе сложных бизнес процессов очень трудно определить факт соответствия текущих полномочий субъекта к объекту доступа с соответствующим уровнем секретности [2].

В связи с этим возникает задача обеспечения безопасности при обработке данных в условиях среды облачных вычислений, которая требует построения гибкой ИТ-инфраструктуры на основе общедоступной среды облачных вычислений. В то же время для обработки конфиденциальной информации в ИТ-инфраструктуру необходимо включать демилитаризованные компоненты, роль которых могут выполнять частные облака, контролируемые внутренними силами организации [3].

1. Формализованная модель безопасности процессов обработки конфиденциальных данных

Для построения формализованной модели безопасности рабочих процессов в среде облачных вычислений в качестве основы рассматриваются существующие положения дискреционного, мандатного, ролевого управления доступом, безопасности информационных потоков, в том числе формальная модель безопасности Белла-ЛаПадула с использованием ключевых элементов теории графов.

С целью модификации предполагается расширение классической модели безопасности Белла-ЛаПадула на новые ключевые составляющие с последующей её интерпретацией для описания требований безопасности информационных рабочих процессов, протекающих в среде облачных вычислений [3]. Необходимо отметить, что использование классической теоремы является отправной точкой для описания и формализации модели безопасности рабочего процесса в среде облачных вычислений. Для преодоления ограничений, присущих модели Белла-ЛаПадула, вводятся дополнительные правила по обеспечению ИБ в рамках новой среды обработки информационных потоков.

Основываясь на основных положениях классической модели безопасности, модифицируем её применительно к рабочим процессам, протекающим в среде облачных вычислений.

- Представим облачные сервисы в виде субъектов (T), а данные в виде объекта (O).

- Определим набор действий (A), который субъект (T) может совершить с объектами (O). Сервис рабочего информационного процесса оперирует с данными путём применения операций чтения и записи. В результате получаем набор действий (A): $A = \{r, w\}$.

- Определим множество функций безопасности (L) для облачного сервиса.

- Определим матрицу доступов, как: $M : TxO \rightarrow A$.

Например, если сервис t_1 совершает операцию чтения над данными O_1 , то запись в матрице будет выглядеть, как: $t_1xO_1 \rightarrow r$. Если сервис t_1 совершает операцию записи данных O_1 , то запись принимает вид: $t_1xO_1 \rightarrow w$.

- Определим уровни конфиденциальности данных, как $B : SxO \rightarrow A$.

- Определим текущие уровни доступа сервиса к данным, как $C : S \rightarrow L$.

- Введём в модель новый элемент: карта текущих размещений блоков рабочего процесса $l : S + O \rightarrow L$.

При рассмотрении классического сценария обеспечения многоуровневого доступа система проходит через множество состояний. Модель принимает различные значения для матрицы полномочий, прав доступа, разрешений и размещения для каждого конкретного случая. Тем не менее, исполнение информационного потока происходит в конкретном состоянии. Обычно сервис ожидает разрешения, значение которого постоянно для всех использований этого сервиса в рабочих процессах. В то же время размещение для каждого рабочего процесса может быть определено в самом начале или определяться динамически при каждом запуске. Рассматриваемая модель является общей и не делает никаких предположений по этому поводу.

Модель Белла-ЛаПадула утверждает, что система безопасна по отношению к вышеописанной модели, если выполняются следующие условия, что

\forall субъект $T \in T$ и \forall объект $o \in O$, тогда можно описать авторизацию, как:

$$B_{to} \subseteq M_{to}, \quad (1)$$

а разрешение:

$$l(t) \leq c(t). \quad (2)$$

Запрет считывания информации сервисом, имеющей уровень доступа ниже уровня секретности, как:

$$k \in B_{to} \Rightarrow c(t) \geq l(o) \quad (3)$$

Запрет сервису понижать уровень секретности информации, к которой он допущен как:

$$w \in B_{to} \Rightarrow l(t) \leq l(o) \quad (4)$$

Для рабочего процесса, протекающего в среде облачных вычислений последствия этих условий можно выразить в виде следующих положений.

(1) Все действия, выполняемые сервисами, должны соответствовать их полномочиям.

(2) Сервисы могут функционировать только на узле облачной инфраструктуры с уровнем конфиденциальности (текущим местом размещения) меньшим или равным его разрешению (текущему доступу).

(3) Сервис не может прочитать данные, которые имеют более высокий уровень секретности, чем его собственное разрешение (текущий доступ).

(4) Сервис не может записать данные на узел с более низким уровнем секретности, чем его собственный.

При этом должны быть соблюдены правила:

$$c(t_1) \geq l(o_1), \quad (5)$$

$$l(o_1) \geq l(t_1). \quad (6)$$

Назначение уровня конфиденциальности для данных в рабочем информационном процессе аналогично присвоению уровня объекту в классической модели Белла-ЛаПадула, но присвоение уровня доступа для сервиса может оказаться менее очевидным. Дело в том, что организация может иметь различные уровни конфиденциальности данных для разных наборов сервисов. Например, внутренний сервис с высокой степенью доверия, или сервис, предоставляемый надежным поставщиком, будет иметь высокую степень защищенности для обработки конфиденциальных данных, в то время сервис как сервис, функционирующий в не доверенной зоне, может привести к утечке этих данных.

Когда специалисты по информационной безопасности организации определяют места размещения для сервисов конкретного рабочего процесса на основании

экспертной оценки, в некоторых случаях может оказаться, что компонент для размещения сервиса имеет уровень безопасности ниже, чем его текущий уровень доступа [3]. Это в свою очередь позволит сервису создавать данные с более низким уровнем конфиденциальности, что противоречит **-свойству* модели управления доступом Белла-ЛаПадула. В связи с возможным появлением такого рода ошибок, необходимо предусмотреть системный метод автоматического размещения рабочего процесса между компонентами облачной среды.

Для решения поставленной задачи рассмотрим, как классическая модель управления доступом Белла-ЛаПадула, примененная к рабочим информационным процессам, может быть расширена для учёта требований безопасности при распределении процессов между компонентами среды облачных вычислений. Поскольку облачная архитектура позволяет выбрать для размещения более одного облака на выбор, необходимо принять решение относительно того, как следует распределить данные и облачные сервисы между компонентами облачной архитектуры с разными уровнями защищенности.

На практике эксперт по безопасности или системный администратор принимает субъективное мнение о разрешённом уровне доступа рабочего процесса и уровне конфиденциальности данных на компоненте облачной среды, на котором эти данные могут быть развернуты.

Таким образом, актуальным становится вопрос расширения модели управления доступом рабочего процесса в целях обеспечения системного принятия решения о том, где сервисы и данные рабочего информационного процесса могут быть развернуты в рамках *гибридной защищенной облачной среды* для обеспечения непрерывности бизнеса и соблюдения требований безопасности.

Для этого в классическую модель добавим следующие новые переменные.

1. Карта размещений рабочего процесса.

Карта размещения рабочего информационного процесса должна включать в себя доступные узлы облачных вычислений, которые обозначим, как P :

$$l : T + O + P \rightarrow L.$$

2. Карта присвоений сервисов и данных к облаку.

Показатель H будет использоваться для описания присвоения каждого сервиса и данных в облаке:

$$H : T + O \rightarrow P.$$

Сформулируем новое правило, говорящее о том, что блок рабочего процесса (сервис или данные) может быть развернут только на облаке только в том случае, если уровень конфиденциальности облака больше или равен текущему уровню доступа сервиса и уровню конфиденциальности данных. Например, для блока x на облаке y справедливо следующее неравенство:

$$l(p_y) \geq l(b_x). \quad (7)$$

Если в H данные O_1 располагаются на облаке p_a , сервис t_1 на облаке p_b , а O_2 на облаке p_c , то должны выполняться следующие условия.

$$l(p_a) \geq l(o_1), \quad (8)$$

$$l(p_b) \geq l(t_1), \quad (9)$$

$$l(p_c) \geq l(o_2). \quad (10)$$

Это позволяет записать формулу (6) в следующем виде:

$$l(p_c) \geq l(o_2) \geq l(t_1) \quad (11)$$

2. Автоматизация распределения рабочего процесса в гибридной среде облачных вычислений

Используя полученную модификацию модели доступа Белла-ЛаПадула можно автоматически получить все допустимые варианты распределения рабочего процесса. Это достигается за счёт прохождения двух этапов.

Во-первых, определим новый вводный параметр для учёта разных компонентов облачной среды в виде (P) и примем во внимание набор сервисов (T), набор данных (O) и карту зон безопасности (l).

Используя правило (7), определим варианты (V) перехода сервисов и данных между облаками.

$$V: T + O \rightarrow P$$

$$V = \{b \rightarrow p \mid b \in T + O, p \in P, l(b) \leq l(p)\}$$

В качестве примера рассмотрим рабочий процесс, выполняющий аналитические вычисления над конфиденциальными данными в гибридной среде облачных вычислений, состоящей из двух типов облаков. На рисунке 1 изобразим граф, который включает в себя последовательное выполнение двух сервисов с разными входными и выходными данными.



Рисунок 1. Граф рабочего процесса с последовательным выполнением двух облачных сервисов

В таблице 1 приведён пример зон безопасности и разрешений с двумя уровнями конфиденциальности 0 и 1. Частное облако с повышенным уровнем безопасности определим, как c_1 , общедоступное облако с базовым уровнем безопасности, как c_0 . Конфиденциальные данные O_1 должны храниться и обрабатываться только на частном облаке, данные O_2 , O_3 можно хранить и в рамках общедоступного облака. Сервис t_1 имеет разрешение на доступ к конфиденциальным данным только в зоне безопасности 1, но его текущее размещение определено в зоне безопасности 0, поэтому в результате его работы создаются выходные данные в зоне безопасности 0 без нарушения *- свойства теоремы Белла-ЛаПадула.

Таблица 1. Размещение и разрешения для примера анализа критически важных данных

Вершина графа	Зона безопасности (l)	Разрешение (c)
o_1	1	
t_1	0	1
o_2	0	
t_2	0	0
o_3	0	
c_0	0	
c_1	1	

На основании правил переходов блоков рабочего процесса между компонентами облачной среды из разных зон безопасности покажем возможные варианты размещения каждого блока в таблице 2.

Таблица 2 – Возможные переходы блоков рабочего процесса между компонентами среды облачных вычислений

Вершина графа	Частное облако c_1	Общедоступное облако c_0
o_1	x	
t_1	x	x
o_2	x	x
t_2	x	x
o_3	x	x

После определения всех допустимых переходов сервисов и данных в облаках, множество всех действительных развертываний рабочего процесса будет определяться по формуле:

$$W: (T + O \rightarrow P) \rightarrow \{(T + O \rightarrow P)\} = \{w \in \|\|V\|\|, \forall b \in T + O. \exists p \in P. b \rightarrow p \in w, |w| = |T + O|\}$$

где: $\|\|V\|\|$ – это показательное множество (множество всех подмножеств) V , $|W|$ – это количество элементов (мощность множества) W .

Алгоритмически W вычисляется путем перекрёстного произведения присвоения блоков на облака, содержащихся в V . В результате получаем все возможные действительные развертывания рабочего процесса (W) (рис. 2). Облако, на котором

развернуты данные или сервис будем обозначать, как верхний индекс, например:

d_x^y – это данные x , развернутые на облаке y .

$$o_1^1 \rightarrow t_1^0 \rightarrow o_2^0 \rightarrow t_2^0 \rightarrow o_3^0$$

$$o_1^1 \rightarrow t_1^0 \rightarrow o_2^0 \rightarrow t_2^0 \rightarrow o_3^1$$

$$o_1^1 \rightarrow t_1^0 \rightarrow o_2^1 \rightarrow t_2^0 \rightarrow o_3^0$$

$$o_1^1 \rightarrow t_1^0 \rightarrow o_2^1 \rightarrow t_2^0 \rightarrow o_3^1$$

$$o_1^1 \rightarrow t_1^0 \rightarrow o_2^0 \rightarrow t_2^1 \rightarrow o_3^0$$

$$o_1^1 \rightarrow t_1^0 \rightarrow o_2^0 \rightarrow t_2^1 \rightarrow o_3^1$$

$$o_1^1 \rightarrow t_1^0 \rightarrow o_2^1 \rightarrow t_2^1 \rightarrow o_3^0$$

$$o_1^1 \rightarrow t_1^0 \rightarrow o_2^1 \rightarrow t_2^1 \rightarrow o_3^1$$

$$o_1^1 \rightarrow t_1^1 \rightarrow o_2^0 \rightarrow t_2^0 \rightarrow o_3^0$$

$$o_1^1 \rightarrow t_1^1 \rightarrow o_2^0 \rightarrow t_2^0 \rightarrow o_3^1$$

$$o_1^1 \rightarrow t_1^1 \rightarrow o_2^1 \rightarrow t_2^0 \rightarrow o_3^0$$

$$o_1^1 \rightarrow t_1^1 \rightarrow o_2^1 \rightarrow t_2^0 \rightarrow o_3^1$$

$$o_1^1 \rightarrow t_1^1 \rightarrow o_2^0 \rightarrow t_2^1 \rightarrow o_3^0$$

$$o_1^1 \rightarrow t_1^1 \rightarrow o_2^0 \rightarrow t_2^1 \rightarrow o_3^1$$

$$o_1^1 \rightarrow t_1^1 \rightarrow o_2^1 \rightarrow t_2^1 \rightarrow o_3^0$$

$$o_1^1 \rightarrow t_1^1 \rightarrow o_2^1 \rightarrow t_2^1 \rightarrow o_3^1$$

Рисунок 2. Множество всех действительных размещений блоков рабочего процесса между компонентами среды облачных вычислений

3. Включение компонента безопасной передачи данных в гибридной среде облачных вычислений

Другим не менее важным вопросом при построении формализованной модели безопасности рабочих процессов в среде облачных вычислений является то, что применение метода в текущей постановке в чистом виде является невыполнимой задачей, так как практически реализовать его в рамках распределенной системы затруднительно по следующим причинам:

1) сервис может генерировать выходные данные непосредственно на другом облаке, без предварительного сохранения данных на компоненте, на котором он сам размещен;

2) сервис может использовать в качестве входной информации данные из другого облака без обязательного сохранения их на своём компоненте.

Для преодоления указанных ограничений, во-первых, введем понятие нового вида сервиса – *транспортного*, который будет передавать данные из одного облака в другое. Аналогом транспортного сервиса является оператор обмена в распределенной обработке запросов.

Переход будет осуществляться за счёт добавления в модель новых компонентов, функционирующих на облаке-источнике и облаке-получателе. Транспортный сервис принимает данные на одном облаке и создает её копию на другом. Все рабочие процессы из множества W трансформируются и включают в себя транспортные сервисы.

Введём четыре правила преобразования графа информационного потока.

$$o_j^a \rightarrow t_i^a \Rightarrow o_j^a \rightarrow t_i^a \quad (12)$$

$$o_j^a \rightarrow t_i^b \Rightarrow o_j^a \rightarrow \text{передатчик} \rightarrow o_j^b \rightarrow t_i^b \quad (13)$$

$$t_i^a \rightarrow o_j^a \Rightarrow t_i^a \rightarrow o_j^a \quad (14)$$

$$t_i^a \rightarrow o_j^b \Rightarrow t_i^a \rightarrow o_j^a \rightarrow \text{передатчик} \rightarrow o_j^b \quad (15)$$

Преобразования (12) и (14) отражают тот факт, что если оба узла размещены на одном облаке, то включения дополнительных модификаций не требуется. В преобразованиях (13) и (15) вводится новый компонент (*транспортный сервис*) для передачи данных между облаками.

Создание новых копий данных с помощью правил (13) и (15) может привести к потенциальным проблемам раскрытия копируемых данных. При применении правила (13), необходимо удостовериться, что облако b имеет уровень конфиденциальности достаточный для хранения копии данных o_j , которая наследует уровень конфиденциальности оригинала. В силу этих причин должны быть соблюдены следующие правила:

$$l(p_b) \geq l(o_j) \quad (16)$$

Аналогично, для правила (15):

$$l(p_a) \geq l(o_j) \quad (17)$$

Если происходит нарушение любого приведенного условия, то, варианты, по которым происходит распределение рабочего процесса, перестают отвечать установленным требованиям безопасности, должны быть исключены из набора W надёжных переходов. Докажем, что нарушение конфиденциальности может иметь место только в двух конкретных случаях.

Во-первых, рассмотрим (16). По правилу (2) получим:

$$c(t_i^b) \geq l(t_i^b) \quad (18)$$

Сначала рассмотрим случай, когда

$$c(t_i^b) = l(t_i^b), \quad (19)$$

при котором текущий уровень доступа объекта соответствует его расположению на карте зон безопасности. Правила (3) и (4) при этом изменяются на:

$$c(t_i^b) \geq l(o_j) \quad (20)$$

и

$$c(t_i^b) = l(t_i^b) \quad (21)$$

Тогда по правилу (19) получаем, что:

$$l(p_b) \geq l(t_i^b) \geq l(o_j) \Rightarrow l(p_b) \geq l(o_j), \quad (22)$$

что подтверждает выполнение правила (16) и доказывает отсутствие нарушений информационной безопасности.

Однако, если:

$$c(s_i^b) \geq l(s_i^b) \quad (23)$$

т. е. уровень безопасности сервиса выше его уровня безопасности его текущего размещения, то комбинируя результат (23) с (3) и (4) получаем:

$$l(s_i^b) < c(s_i^b) \geq l(d_j) \quad (24)$$

$$l(p_b) \leq l(s_i^b) < c(s_i^b) \quad (25)$$

что не исключает

$$l(p_b) < l(d_j) \quad (26)$$

При таком случае правило (16) нарушается, и текущее распределение рабочего информационного процесса не соответствует требованиям безопасности.

Рассмотрим данные, которые получаются в результате работы сервиса. Правило (17) может быть нарушено путем применения преобразований (15) в случае, когда сервис t_1 производит операцию записи данных (4) таким образом, выполняется условие $l(p_a) < l(o_j)$. Переход от $l(p_b)$ до $l(o_1)$ осуществляется по правилу (13), которое позволяет рабочему процессу создавать копию o_1 . Переход от $l(p_b)$ до $l(o_2)$ совершается по правилу (15), которое делает возможным добавление копии o_2 . Применение преобразований (16) и (17) к рабочему процессу из рисунка 7 не допускает использование половины возможных вариантов распределения рабочего процесса. Удаление двух дублей, созданных в результате преобразования, оставляет шесть допустимых вариантов, которые показаны на рисунке 3.

$$o_1^1 \rightarrow t_1^1 \rightarrow o_2^1 \rightarrow \text{передатчик} \rightarrow o_2^0 \rightarrow t_2^0 \rightarrow o_3^0$$

$$o_1^1 \rightarrow t_1^1 \rightarrow o_2^1 \rightarrow \text{передатчик} \rightarrow o_2^0 \rightarrow t_2^0 \rightarrow o_3^0 \rightarrow \text{передатчик} \rightarrow o_3^1$$

$$\begin{aligned}
 & o_1^1 \rightarrow t_1^1 \rightarrow o_2^1 \rightarrow \text{передатчик} \rightarrow o_2^0 \rightarrow \text{передатчик} \rightarrow o_2^1 \rightarrow t_2^1 \rightarrow o_3^1 \\
 & \quad \rightarrow \text{передатчик} \rightarrow o_3^0 \\
 & o_1^1 \rightarrow t_1^1 \rightarrow o_2^1 \rightarrow \text{передатчик} \rightarrow o_2^0 \rightarrow \text{передатчик} \rightarrow o_2^1 \rightarrow t_2^1 \rightarrow o_3^1 \\
 & o_1^1 \rightarrow t_1^1 \rightarrow o_2^1 \rightarrow t_2^1 \rightarrow o_3^1 \rightarrow \text{передатчик} \rightarrow o_3^0 \\
 & o_1^1 \rightarrow t_1^1 \rightarrow o_2^1 \rightarrow t_2^1 \rightarrow o_3^1
 \end{aligned}$$

Рисунок 3. Варианты распределения рабочего процесса после добавления транспортного сервиса

Альтернативный вариант отображения распределений рабочего процесса с использованием специальных компонентов для передачи данных между облаками показан на рисунке 4.



Рисунок 4. Допустимые распределения рабочих процессов в гибридной среде облачных вычислений

Для иллюстрации уровня безопасности 0 для общедоступной облачной среды (ООС), данных и сервисов использованы контуры, выделенные зеленым цветом, на уровне 1 (частной облачной среды, ЧОС) – красным цветом. Построенные диаграммы позволят специалисту ИБ получить представление о возможных вариантах развёртывания рабочих процессов в рамках гибридной облачной архитектуры. Для примера описания работы метода были использованы простые, линейные рабочие процессы, в то же время данный метод может быть применен и для ориентированных графов, независимо от сложности их структуры.

Заключение

Описанный подход предлагается в качестве основы для автоматизации процесса разделения рабочих процессов в рамках гибридной среды облачных вычисле-

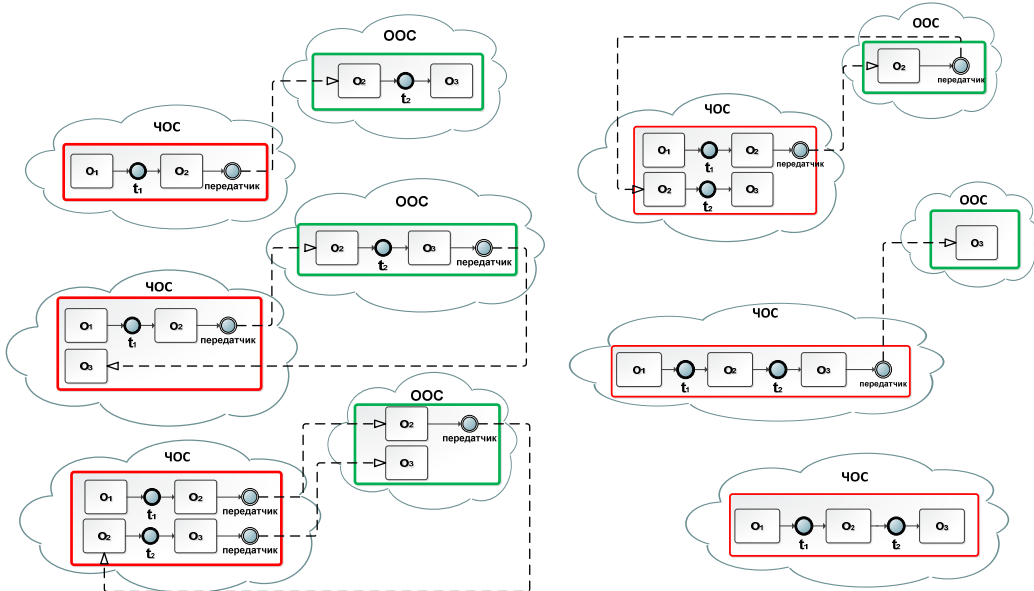
ний. Данный подход должен заменить процесс выбора администратором возможного варианта распределения процессов, который носит субъективный характер и может привести к ошибке. На смену ручному определению предлагается внедрить автоматический механизм, реализующий работу описанного метода, который определит допустимые параметры на основе строгого набора правил, а затем предложит лучший на основании стоимостной модели. Рассмотренный подход, имеет преимущества, которые могут снизить, как потенциальные нарушения безопасности, так и снизить расходы на ИТ-инфраструктуру.

▲ Литература

- [1] ЦАРЕГОРОДЦЕВ А. В., КАЧКО А. К. Обеспечение информационной безопасности на облачной архитектуре организации // *Национальная безопасность*. – М.: Изд. «НБ Медиа», 2011. – № 5. – С. 25-34.
- [2] PETER MELL, TIMOTHY GRANCE. NIST Special Publication 800-145. The NIST Definition of cloud computing. – 2011. – 3 p.
- [3] ЦАРЕГОРОДЦЕВ А. В. Формализованная модель безопасности рабочих процессов информационно-телекоммуникационных систем, функционирующих на основе технологии облачных вычислений // *Нелинейный мир*. – М.: Изд-во Радиотехника, 2013. – № 9. – Т. 11. – С. 610-621.

▲ References

- [1] TSAREGORODTSEV A. V., KACHKO A. K. Ensuring of information security in the cloud architecture of organization // *National security*. – Moscow: «NB Media» Publishing, 2011.
- [2] PETER MELL, TIMOTHY GRANCE. NIST Special Publication 800-145. The NIST Definition of cloud computing. – 2011. – 3 p.
- [3] TSAREGORODTSEV A. V. The workflow security formalized model for cloud computing informational telecommunication systems // *Nonlinear world*. – Moscow: «Radiotekhnika» Publishing, 2013.

Автоматизация процесса распределения обработки критичных данных в гибридной среде облачных вычислений

Анатолий Царегородцев, Анна Зеленина

Аннотация:

Широкое распространение и применение облачных вычислений диктует необходимость адаптации и доработки существующих моделей безопасности информационно-телекоммуникационных систем. Для достижения конфиденциальности данных необходимо рассмотреть преимущества моделей развёртывания облачных сервисов и предусмотреть процедуру распределения рабочего процесса между компонентами среды облачных вычислений.

Ключевые слова:

Модели безопасности информационно-телекоммуникационных систем, облачные вычисления, публичное облако, частное облако, гибридное облако, требования безопасности, теория графов, конфиденциальность данных.

Prof. Anatoly Tsaregorodtsev, D. of Sc. (Engineering)
Moscow State Linguistic University, Russia
AVTsaregorodtsev@lingvanet.ru

Associate Prof. Anna Zelenina, Ph.D.
Voronezh Institute of High Technologies, Russia
snakeans@gmail.com

Instructions for Authors

International scientific journal Information Technology Applications jointly issued by Faculty of Informatics of Paneuropean University and Civil association EDUCATION-SCIENCE-RESEARCH in Bratislava, offers space to publish:

<i>Scientific articles</i>	in the range of 20 standard pages (there is possible to place up at the most 1800 characters including character spacing on the one page of A4 format). Reports in the range of 5 standard pages
<i>Discussions</i>	in the range of 2 standard pages
<i>Information</i>	in the range of 1 standard page

The journal presents practical and theoretical knowledge about the use of information technology mainly in the field of economy, business, law, media, psychology, education, power engineering and public administration and next. It is written in Slovak, English, Russian and Czech language. The journal is published biannually. Contributions will be accepted only in electronic form in doc or docx format on vvv.esr@gmail.com in the form of **author's surname.doc (docx)**. Main requirement of accepting the contribution is its originality. Another Condition for publishing the contribution is the positive attitude of editorial board and two independent reviewers.

The contribution must be written in MS WORD, Times New Roman font, single spacing of the lines, A4 page format, 2.5 cm margins, not to number the pages according to the following structure:

Required part

1. Title of the contribution in English language: font size 16, bold, center alignment.
Omit line
2. Name and surname of the author (or authors separated by hyphen): font size 14, italic, center alignment. *Omit line*
3. Abstract: font size 12, bold, left alignment. The text of the Abstract written in English on a new line, range of 250-300 words, font size 11, justified alignment: *scientific goal/methods, conclusions according to* <http://info.emeraldinsight.com/authors/guides/abstract.html>.
4. Key words: font size 12, bold, left alignment. Text written in English on a new line, font size 11, justified alignment, range of 3-5 key words (separated by comma). *Omit line*
5. ACM Computing Classification System: font size 12, bold, left alignment. To adduce the classification codes (font size 11, separated by comma) on the same line according to <http://www.acm.org/about/class/2012>. *Omit line*
6. Dividing the contribution to a clearly defined parts (Introduction, Conclusion) and to numbered chapters (1, 2, ...) and subchapters (1.1, 1.1.1, 1.1.2, ..., 2.1, 2.1.1, 2.1.2, 2.2, ...): font size 12, bold, justified alignment. Introduction, Conclusion – bold, not to number; Chapters, Subchapters – to number, bold

Tables, graphs a pictures to put straight into the text and to mark by sequential number and description (font size 11, italic, left alignment) - Examples:

Table 1: title.

Graph 1: title.

Picture 1: title.

Below it to mention the source – *Source: source name* (font size 11, italic, left alignment)

Bibliographic references adduced in the text according to STN ISO 690 standard and international standards in a form (name of the author, year of issue)

Citations appear in the text, in direct citation is necessary to add the page number.

7. Literature: font size 12, bold, left alignment. Literature List alphabetized on new lines, font size 12, justified alignment, with all identification data according STN ISO 690 standard if it concerns *book, chapter of book, contribution from almanac, article from journal, internet documents* (<http://owl.english.purdue.edu/owl/resource/560/01>).

8. Author's address: font size 12, bold, left alignment, address placed on a new line, font size 12, left alignment serially according to *Name and surname of the author, degree, address of the institute, e-mail*.

Optional part

9. Title of the contribution in other language: font size 16, bold, center alignment.
Omit line

10. Abstract: according to the point 3 (but written in other language).

11. Key words: according to the point 4 (but written in other language).



VORONEZH INSTITUTE OF HIGH TECHNOLOGIES (VIHT) is an autonomous non-profit educational organization of higher education. VIHT has been carried out fundamental and professional training of high-skilled personnel in the fields of IT-technologies, Computer Science and Engineering, Economics and Management, Human Resource Management, Management in Service and Tourism Industries since 1992.

VIHT has international certification by the International Education Society Ltd., London, and ISO 9001-2008 quality certification of educational programs.

VIHT introduces new technologies and teaching methods cooperating with main study centers of international companies such as Cisco Network

Academy, which provides access to CCNA qualification for further employment in the field of telecommunications; Softline Study Centre and Microsoft IT Academy, which allow going through further professional certification in the field of IT-Technologies. VIHT is a partner of the National Centre of Manager Certification.

VIHT takes up leading positions in the ranking of higher educational institutions offering IT-education in Voronezh.

VIHT realizes a number of international programs of academic mobility of students, internships, Summer/Winter Language Schools, the «Double-Degree Diploma» Programme.



SECONDARY PROFESSIONAL EDUCATION PROGRAMS AT OWN COLLEGE

- PROGRAMMING IN COMPUTER SYSTEMS
- ECONOMICS AND ACCOUNTING



NEW PROGRAMS 2016

- ✓ HARDWARE AND SOFTWARE SETUP TECHNICIAN
- ✓ BANK INSPECTOR
- ✓ ADDITIVE TECHNOLOGIES (3D-MODELING TECHNOLOGIES)
- ✓ OPERATING ACTIVITY IN LOGISTICS
- ✓ LAW AND ORGANIZATION OF SOCIAL SECURITY



HIGHER EDUCATION



BACHELOR DEGREE PROGRAMMES (4 YEAR STUDY)

- HUMAN RESOURCE MANAGEMENT
 - ✓ Personnel Planning and Marketing
- MANAGEMENT
 - ✓ Small Business Management
 - ✓ Corporate Management in Tourism Industry
 - ✓ Corporate Management in Service Industry
- COMPUTER SCIENCE AND ENGINEERING
 - ✓ Personnel Planning and Marketing
- INFORMATION SYSTEMS AND TECHNOLOGIES



SPECIALIST DEGREE PROGRAMS (5 YEAR STUDY)

- FIRE SAFETY



MASTER DEGREE PROGRAMS

- MANAGEMENT (2 YEAR FULL - TIME STUDY)
 - ✓ Management of Business Development
 - ✓ Management of Business Development in Tourism Industry
 - ✓ Management of Business Development in Service Industry
- COMPUTER SCIENCE AND ENGINEERING (2 YEAR FULL - TIME STUDY)
 - ✓ Computer Networks and Telecommunications
 - ✓ Information and Software Support of the Automated Systems



PHD. PROGRAMS

(4 YEAR FULL - TIME STUDY; 5 YEAR EXTRAMURAL STUDY)

- COMPUTER SCIENCE AND ENGINEERING
 - ✓ System Analysis and Information Processing
 - ✓ Management in Socio-Economic Systems



ADVANCED PROFESSIONAL TRAINING AND RETRAINING PROGRAMS

- ✓ MULTIVENDOR CENTRE: CISCO, MICROSOFT, HP, ADOBE, PRINCE2
- ✓ SCHOOL OF DESIGN: Coral Draw, Autodesk 3ds Max, Digital Photography
- ✓ MODERN IT TECHNOLOGIES
- ✓ COMPUTER SCHOOL FOR CHILDREN
- ✓ BUSINESS SCHOOL OF MANAGERS
- ✓ MANAGEMENT IN EDUCATION
- ✓ FSES (Federal State Education Standards)
- ✓ CORPORATE TRAININGS AND SEMINARS
- ✓ TRANSPORT SAFETY
- ✓ BASICS OF FIRE SAFETY

More details at eng.vivt.ru/buklet_eng.pdf

Online tour: www.go.vivt.ru



394043 Voronezh Russia
ul.Lenina, 73 A
Tel. +7-800-55-56-054
iec@vivt.ru
www.vivt.ru

State Accreditation Certificate 90A01 N 0001256 dated to February 02, 2015
valid until February 02, 2021

License to carry out educational activities 90A01 № 0001763 (Reg.№ 1670)
dated to February 12, 2016 without limit in time.



Доступно в
App Store



Google play